

REV.	DATE	DESCRIPTION	BY	C'K'D'
05	10-03-99	Temperature range -55C instead of -25C	K.N.	
A	17-12-01	CONVERSION PDM - BEC 9.3573	NL	

WIRING FACE

MATING FACE

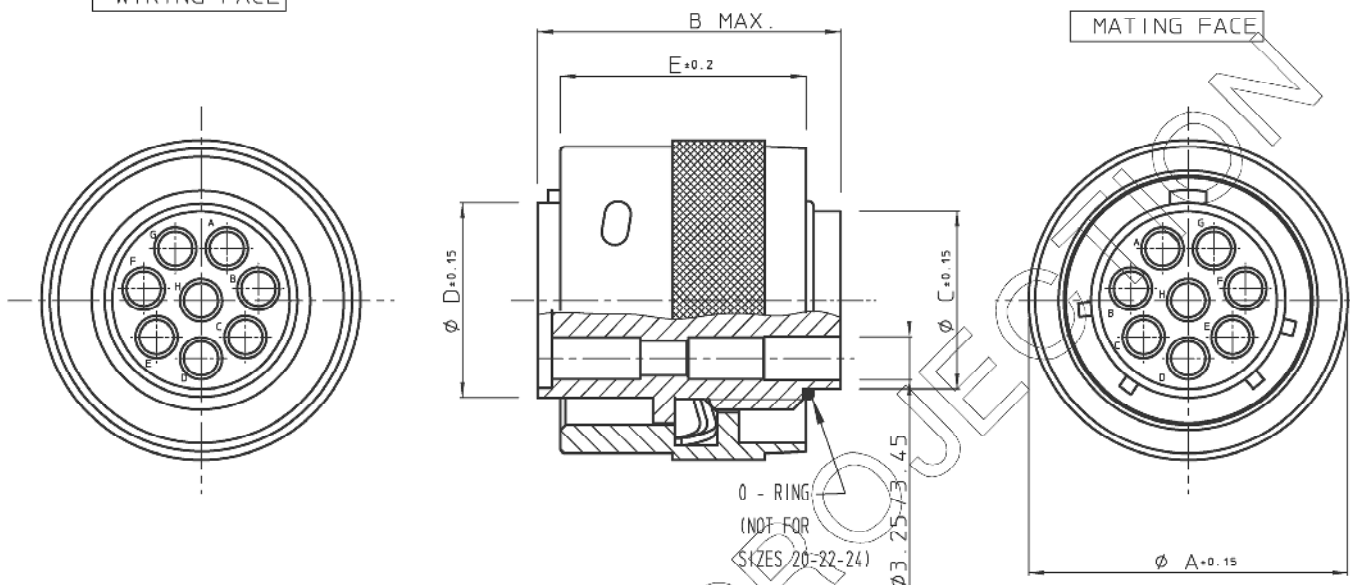

CAT. NUMBER	phi A+0.15	B MAX.	phi C+0.15	phi D+0.15	E+0.2
UTG6104SN	21.6	23.9	10.9	12.2	19.1
UTG6125SN	24.8	23.9	13.8	15.1	19.1
UTG6128SN	24.8	23.9	13.8	15.1	19.1
UTG61412SN	28.0	23.9	17.0	18.3	19.1
UTG61619SN	31.2	23.9	19.9	21.5	19.1
UTG61823SN	34.3	23.9	22.4	24.0	19.1
UTG62028SN	37.5	24.9	25.6	27.2	19.1
UTG62235SN	40.7	24.9	28.5	30.4	19.1
UTG62448SN	43.9	26.2	31.7	33.5	19.1

MATERIAL

UTG6128SN AS SHOWN

- BODY : GLASS-FILLED POLYESTER UL94-V0
COLOUR : BLACK
- BAYONET RING : HIGH STRENGTH CuZn ALLOY, NICKEL PLATED.
- COUPLING SPRING : SPRING STEEL

PERFORMANCE CHARACTERISTICS

- OPERATING TEMPERATURE : -55 °C TO +125 °C.
- INSULATION RESISTANCE : 5000 Mo MIN.
- TEST POTENTIAL : 2000 V EFF.

NOTES

- CONNECTOR ACCEPTS ± 16 STRIP FORMED, MACHINED AND SUBMINIATURE COAXIAL PIN AND SOCKET CONTACTS.
- CONTACTS TO BE ORDERED SEPARATELY : REFER TO TRIM - TRIO CATALOG.
- FOR OTHER INSERT ARRANGEMENTS SEE BS,C ,201458,000

DIT IS ONZE EIGENDOM EN MAG NOCH NAGEMAAKT, HERDRUKT, OVERGEMAAKT AAN DERDEN, NOCH VOOR FABRIKATIE GEBRUIKT WORDEN, ZONDER ONZE SCHRIFTELIJKE TOELATING. BIJ NIET GEBRUIK IS DE TERUGZENDING VERPLICHT.

THIS IS OUR EXCLUSIVE PROPERTY. IT IS NOT TO BE COPIED, REPRINTED OR DISCLOSED TO A THIRD PARTY, NOR USED FOR MANUFACTURING WITHOUT OUR WRITTEN CONSENT, AND HAS TO BE RETURNED TO US IN CASE OF NO USAGE

A
BS,A , 201458 , 004

GEN. ST.	01	02	03	04	05	06	07	08	0D	50	60	70	80	90																	
INT. ST.	10	11	12	13	14	18	20	31	32	33	34	38	39	40	42	43	44	45	46	48	56	70	72	73	75	76	81	82	83	84	88

1DEC ±0.2 1DEC 2DEC ±0.1 2DEC ANGLES ±1° HOEKEN	APPR.	DATE	SIGN.	FEMALE PLUG
	DRAFT	7-6-91	M BUEDS	CAT. No. UTG6----SN
WE RESERVE THE RIGHT TO CHANGE DIMENSIONS OR REQUIREMENTS WITHOUT PRIOR NOTICE.	PROD. MGR.			SOURIAU Route Nationale 23 72470 CHAMPAGNE
ALL DIMENSIONS IN MM	PR. ENG. MGR.			
ALLE AFMETINGEN IN MM	PR. MGT. MGR.			BS,A , 201458,004 NOT EXPORT CONTROLLED DRAWING NR. CUSTOMER DRAWING REVISION