

REVISIONS					
REV	ECO	DESCRIPTION	DATE	BY	APPR
A1	--	RELEASE NEW DRAWING	15JUL20	VITO	TOMMY
A2	--	REVISE THE VIEWS	1/MAR/23	VITO	TOMMY

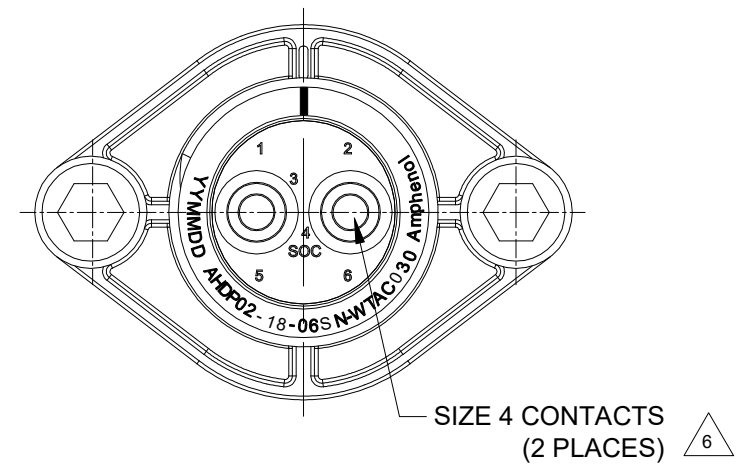
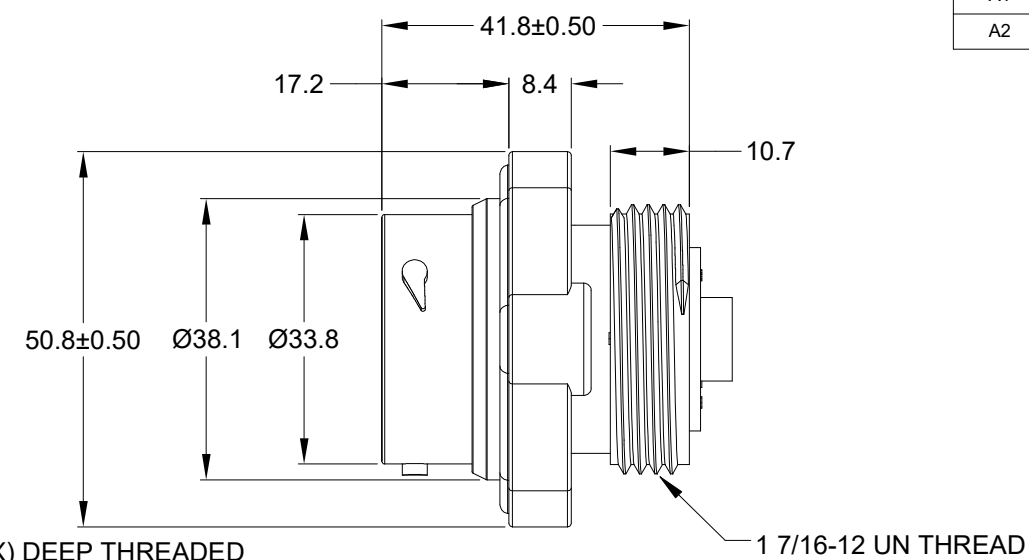
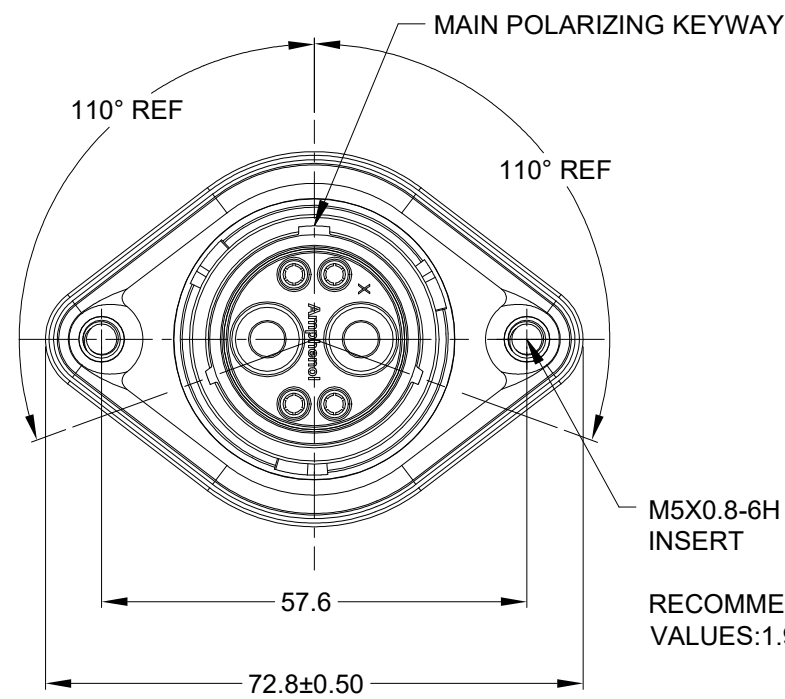

M5X0.8-6H 8mm(2X) DEEP THREADED INSERT
 RECOMMENDED TORQUE VALUES:1.9-2.2 N.m

NOTES: UNLESS OTHERWISE SPECIFIED

- MATERIAL:
 HOUSING: THERMOPLASTIC; BLACK
 SEAL: SILICONE RUBBER
 THREADED INSERT: STAINLESS STEEL
- MODIFICATIONS: WIDE THREAD ADAPTER(WTA);
 STANDARD DIA,WIRE SEAL;
 SEALED PANEL MOUNT;
- SPECIFICATIONS:
 3.1 OPERATING TEMPERATURE: -55°C TO +125°C.
 3.2 DIELECTRIC WITHSTANDING VOLTAGE: LESS THAN 2 MILLIAMPS CURRENT LEAKAGE @ 1500 VOLTS AC.
 3.3 INSULATION RESISTANCE: 1000 MEGOHM MIN @ 25°C.
 3.4 MOISTURE RESISTANCE: IP67&IP69K (MATED CONDITION).
 3.5 MATING CYCLE DURABILITY: 100 CYCLES
 3.6 RoHS COMPLIANT
- MATING PART: AHDP06-18-06P* (* = SEAL TYPE) (C030 OPTION)
- ALL DIMENSIONS ARE FOR REFERENCE USE ONLY.

6 CONTACT SIZE AND WIRE RANGE:

CONTACT SIZE	MIN. INSUL O.D.	MAX. INSUL O.D.	TYPICAL WIRE RANGE	CURRENT RATING
4	6.63 mm (.261in)	7.41mm (.292 in)	6 AWG (16-13mm ²)	100 AMPS

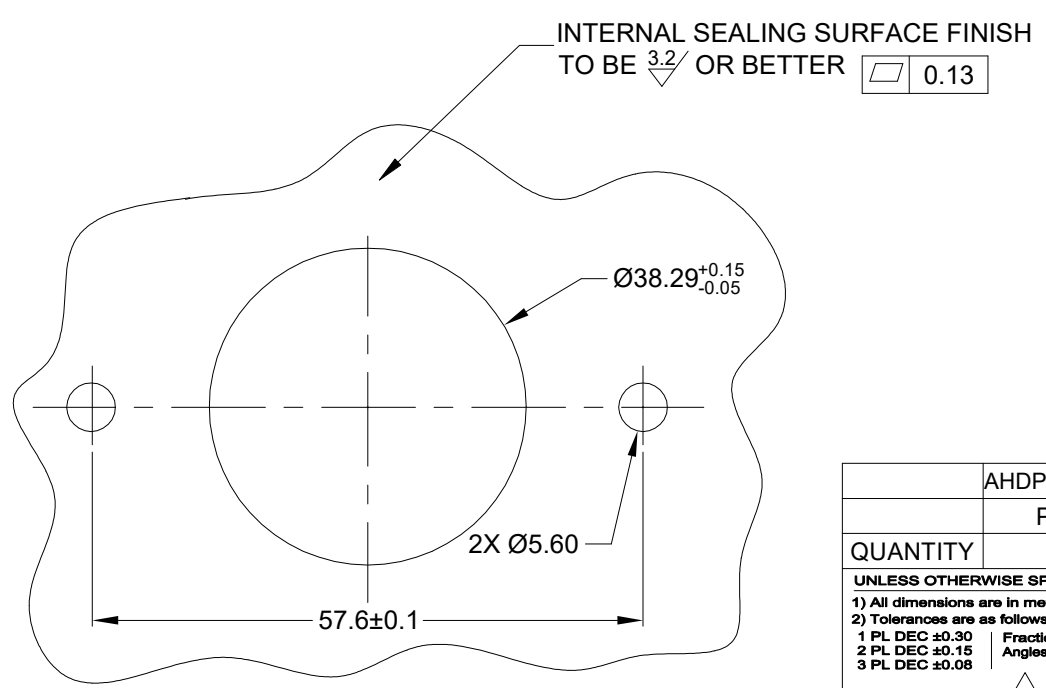

RECOMMENDED PANEL MOUNTING HOLE
 RECOMMENDED PANEL THICKNESS:1.6 TO 4.7MM

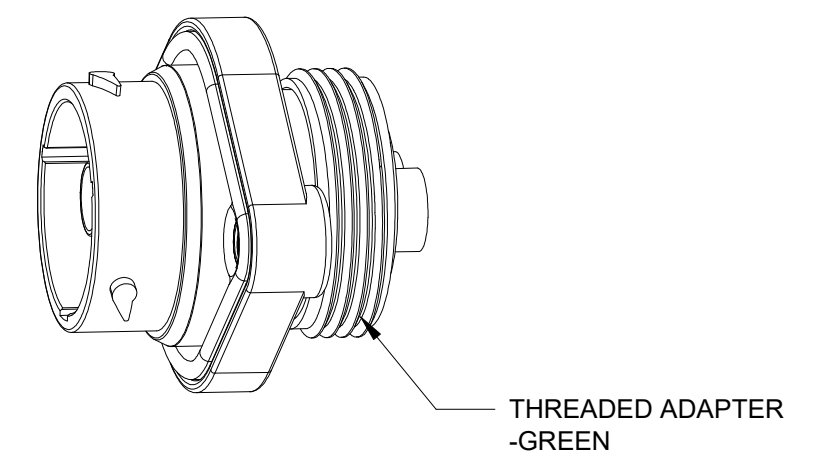

AHDP02-18-06SN-WTAC030		DESCRIPTION		ITEM
QUANTITY	PART NUMBER	MATERIALS LIST		
<p>UNLESS OTHERWISE SPECIFIED 1) All dimensions are in metric(mm). 2) Tolerances are as follows: 1 PL DEC ±0.30 Fractions ±1/64 2 PL DEC ±0.15 Angles ±1° 3 PL DEC ±0.08</p>				
SIGNATURES		DATE		
DRAWN: VITO.LI		1/MAR/23		
CHECKED: ORION.LI		2/MAR/23		
ENGINEER:				
APPROVAL: TOMMY.XIE		3/MAR/23		
MATERIAL SPECIFICATIONS:		CUSTOMER:		
PROCESS SPECIFICATIONS:		THIS DRAWING IS SUPPLIED FOR INFORMATION ONLY. DESIGN FEATURES, SPECIFICATIONS AND PERFORMANCE DATA SHOWN HEREON ARE THE PROPERTY OF THE AMPHENOL CORPORATION. NO RIGHTS OF REPRODUCTION ARE IMPLIED. ALL DIMENSIONS ARE SUBJECT TO NORMAL MANUFACTURING VARIATIONS.		
NEXT ASSY:				
<p>Amphenol Sine Systems - www.amphenol-sine.com 44724 Morley Drive Clinton Township, MI 48036</p>				
<p>2 POS, RECEPTACLE, SOCKET, PANELMATE AHDP SIZE 18, NORMAL SEAL, WTA</p>				
SIZE	TYPE	DWG NO:	REVISION	
B	C-	AHDP02-18-06SN-WTAC030	A2	
SCALE: NONE		SHEET 1 OF 1		

TITLE: 2 POS RECEPTACLE SOCKET, PANELMATE AHDP SIZE 18, NORMAL SEAL, WTA
 DWG NO: AHDP02-18-06SN-WTAC030
 REV: A2
 SH: 1
 OF: 1