

THE INFORMATION CONTAINED HEREIN IS CONSIDERED "PROPRIETARY" TO BEL FUSE INC. AND SHALL NOT BE COPIED, REPRODUCED OR DISCLOSED WITHOUT THE WRITTEN APPROVAL OF BEL FUSE INC.

LED 2 & 4 POLARITY			LED 1 & 3 POLARITY		
PIN 13	PIN 14	COLOR	PIN 15	PIN 16	COLOR
-	+	YELLOW	-	+	YELLOW
+	-	GREEN	+	-	GREEN

RoHS



ELECTRICAL CHARACTERISTICS @ 25°C

URNS RATIO

TP1	1CT : 1CT ±2%
TP2	1CT : 1CT ±2%
TP3	1CT : 1CT ±2%
TP4	1CT : 1CT ±2%

□CL @ 100kHz/100mVRMS

FOR CHANNEL 1 AND CHANNEL 2

11mA DC BIAS 350µH MIN.

Compliant to IEEE 802.3at specification

FOR CHANNEL 3 AND CHANNEL 4

8mA DC BIAS 350µH MIN.

INS. LOSS

0.1MHz TO 1MHz	-1.1 dB MAX
1MHz TO 65MHz	-0.5 dB MAX
65MHz TO 100MHz	-0.8 dB MAX
100MHz TO 125MHz	-1.2 dB MAX

RET. LOSS (MIN) @ 100□HMS ±15%

0.5MHz-40MHz	-18 dB
40MHz-100MHz	-12+20LOG(F/80MHz) dB

CM TO CM REJ

100kHz - 100MHz -30 dB MIN

CM TO DM REJ

100kHz - 100MHz -35 dB MIN

HIPOT (Isolation Voltage): 2250 VDC

100% OF PRODUCTION TESTED TO COMPLY WITH IEEE 802.3 ISOLATION REQUIREMENTS.

BALANCED DC LINE CURRENT 600mA MAX. CONTINUOUS
1.2A MAX. FOR 200 MILLISECONDS

OPERATING TEMPERATURE -40°C TO +85°C

LEDS 1, 2, 3 AND 4

VF (FORWARD VOLTAGE) IF=20mA GREEN 2.2V TYP.
IF=20mA YELLOW 2.1V TYP.

λD (DOMINANT WAVELENGTH) IF=20mA GREEN 570nm TYP. YELLOW
IF=20mA YELLOW 590nm TYP.

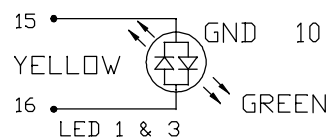
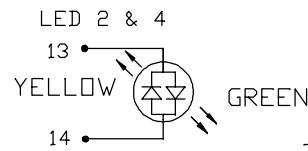

SCHEMATIC

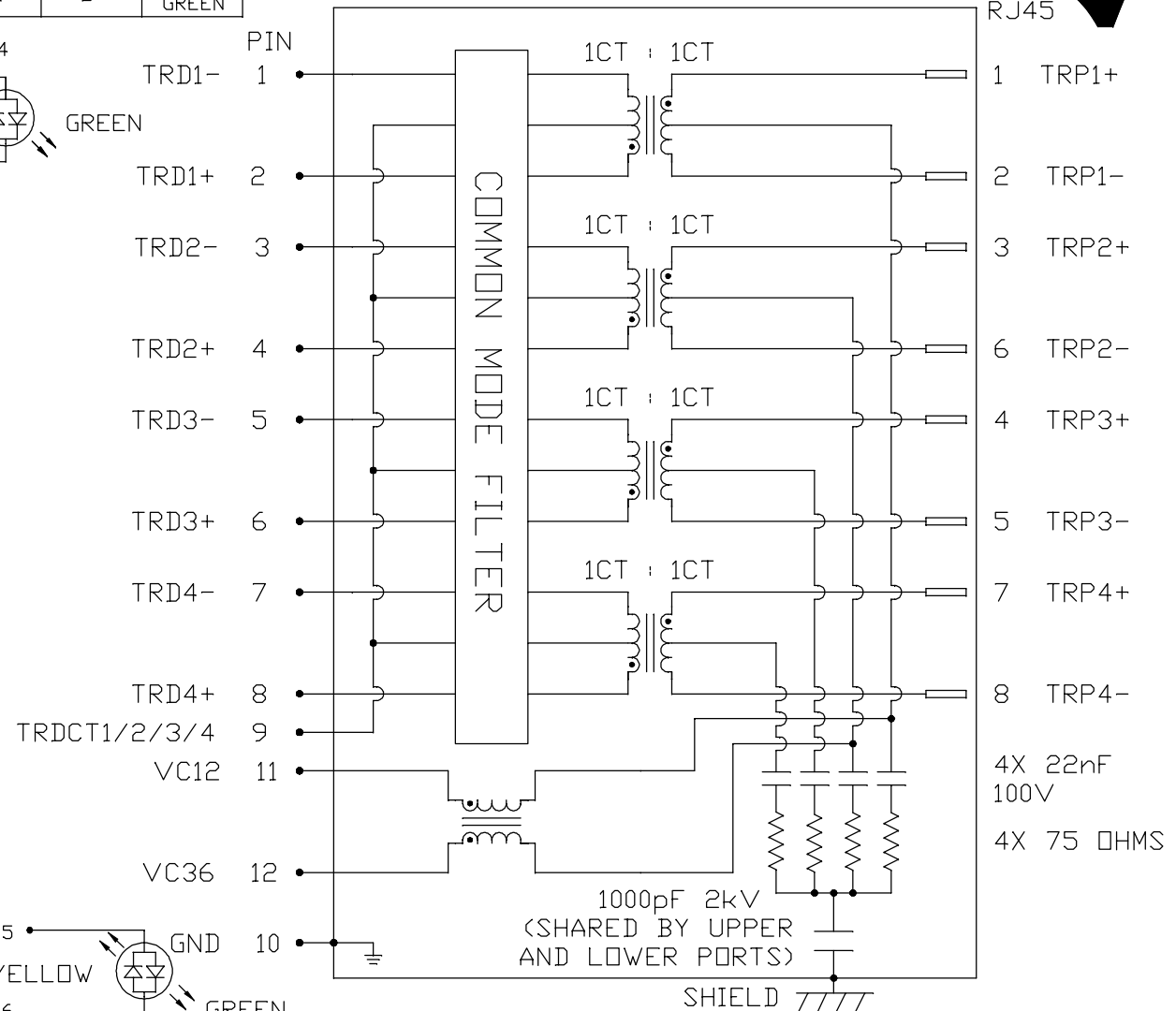

ORIGINATED BY CHOW WANCHUNG	TITLE 2X6 gigabit MagJack® PoEp (Extended temperature)
DATE 2019-03-27	
DRAWN BY XIE YIMING	08AN-2C6R-GK-C PATENTED
DATE 2019-03-27	

PART NO. / DRAWING NO. 08AN2C6RGK-C	STANDARD DIM. TOL. IN INCH	[] METRIC DIM. AS REF.
FILE NAME 08AN2C6RGK-C_B.DWG	.X	UNIT : INCH [mm]
	.XX	SCALE : N/A
	.XXX	SIZE : A4

REV. : B	PAGE : 2
----------	----------



THE INFORMATION CONTAINED HEREIN IS CONSIDERED "PROPRIETARY" TO BEL FUSE INC. AND SHALL NOT BE COPIED, REPRODUCED OR DISCLOSED WITHOUT THE WRITTEN APPROVAL OF BEL FUSE INC.

RoHS

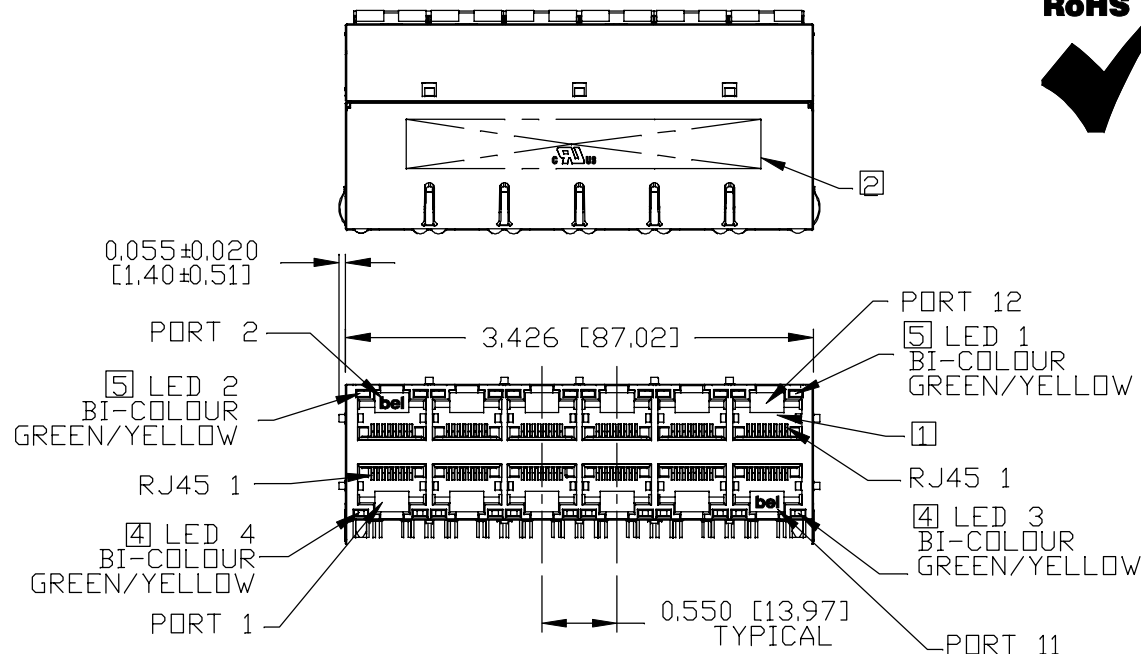
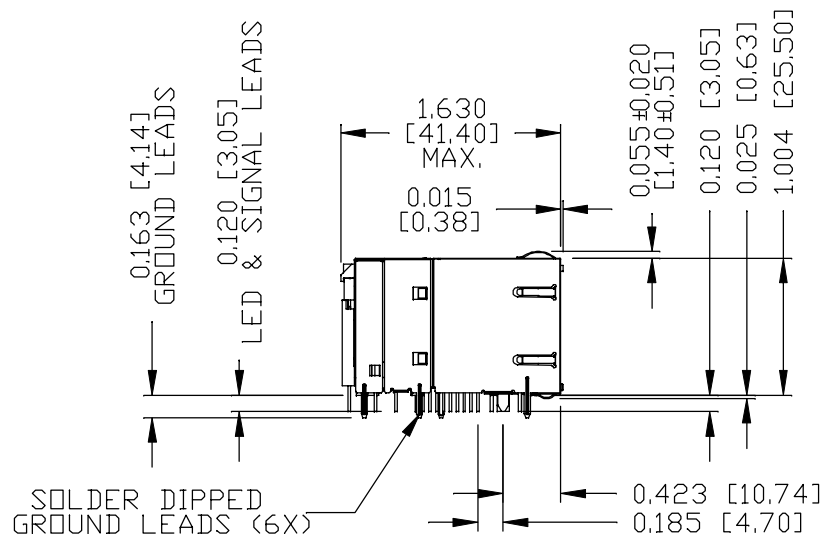

NOTE:

PLASTIC HOUSING: THERMOPLASTIC PBT, BLACK.
 FLAMMABILITY RATING UL 94V-0
 CONTACT PLATING: 50 MICRO-INCH HARD GOLD PLATING OR EQUIVALENT.
 OUTPUT PINS: TIN-COATED COPPER WIRE;
 100 MICRO-INCH MIN MATTE TIN. PINS ARE SOLDER DIPPED.
 METAL SHIELD: NICKEL PLATED ON COPPER ALLOY.
 (ALL GROUND LEADS ARE SOLDER DIPPED)

- 1. JACK CAVITY CONFORMS TO FCC RULES AND REGULATIONS, PART 68 SUBPART F.
- 2. MARK PART WITH MFG LOGO, MFG NAME, PART NUMBER, DATE CODE AND PATENTED.
- 3. THE PRODUCT IS RoHS COMPLIANT.

- 4. SPECIAL LED 3 & 4 CONFIGURATION: TWO STEP LED HEAD, LOW INTENSITY LIGHT.
- 5. SPECIAL LED 1 & 2 CONFIGURATION: SUPER INTENSITY LIGHT.
- 6. THE AXIAL RETENTION FORCE OF RJ PORT IS 15LB MIN..

- 7. THE PRODUCT IS PATENTED PRODUCT. THE PATENT NUMBER ARE U.S. PAT. 7,123,117 AND U.S. PAT. 6,840,817.
- 8. THE PART IS RECOMMENDED FOR WAVE SOLDERING. THE SUGGESTED PEAK WAVE SOLDERING CONDITION IS 260°C MAX AND 10 SECONDS MAX.

ORIGINATED BY
SANDY LIN
DATE 2019-03-27
DRAWN BY
OLIVER ZHANG
DATE 2019-03-27

TITLE
2X6 gigabit MagJack®
PoEp
(Extended temperature)
08AN-2C6R-GK-C
PATENTED

PART NO. / DRAWING NO.
08AN2C6RGK-C
FILE NAME
08AN2C6RGK-C_B.DWG

STANDARD DIM. TOL. IN INCH	[] METRIC DIM. AS REF.
.X	UNIT : INCH [mm]
.XX	SCALE : N/A
.XXX	SIZE : A4

REV. : B PAGE : 3



THE INFORMATION CONTAINED HEREIN IS CONSIDERED "PROPRIETARY" TO BEL FUSE INC. AND SHALL NOT BE COPIED, REPRODUCED OR DISCLOSED WITHOUT THE WRITTEN APPROVAL OF BEL FUSE INC.

RoHS

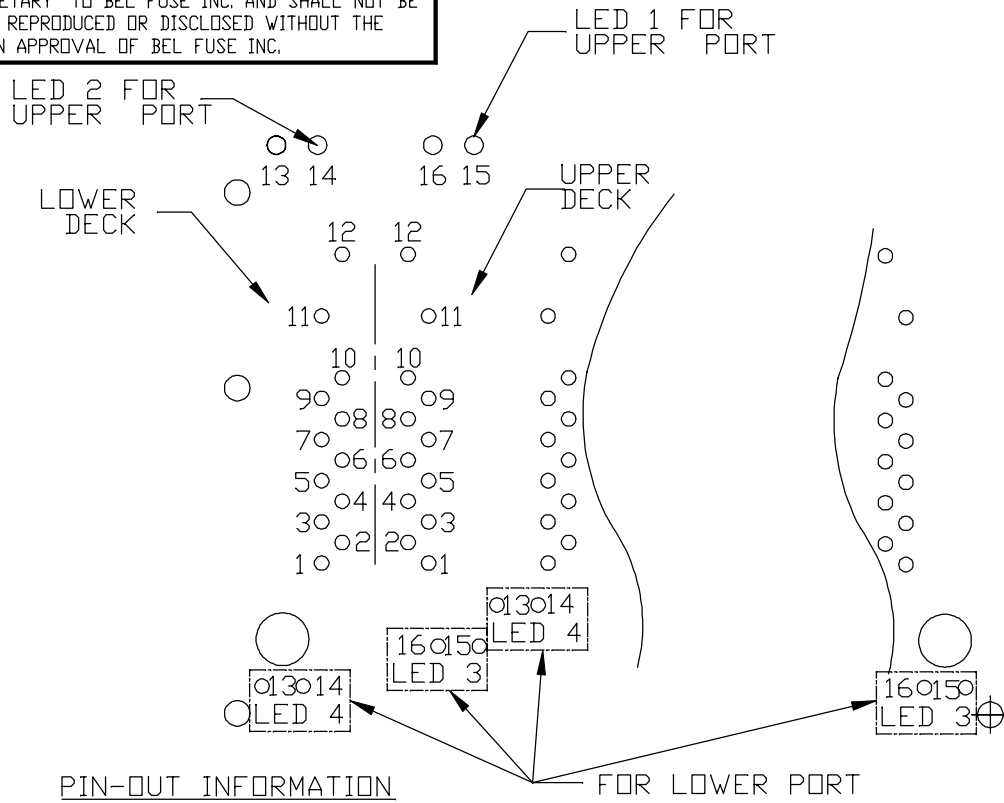

PORT ASSIGNMENT
(COMPONENT SIDE VIEW)

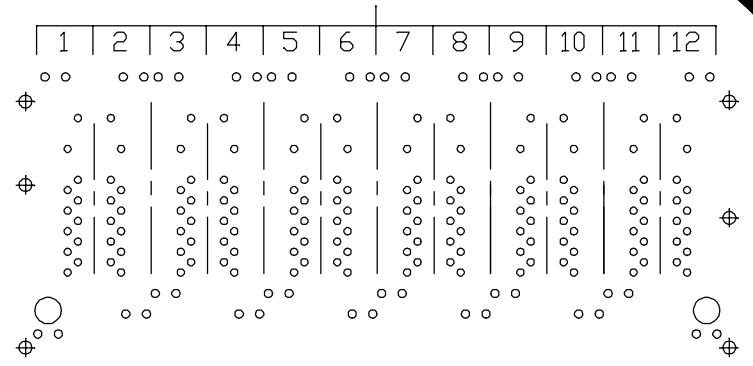

PIN-OUT INFORMATION
(COMPONENT SIDE VIEW)

12	VC36		
11	VC12		
10	GND		
9	TRDCT1/2/3/4		
8	TRD 4+		
7	TRD 4-		
6	TRD 3+		
5	TRD 3-		
4	TRD 2+	16	YELLOW (+)/GREEN (-)
3	TRD 2-	15	YELLOW (-)/GREEN (+)
2	TRD 1+	14	YELLOW (+)/GREEN (-)
1	TRD 1-	13	YELLOW (-)/GREEN (+)

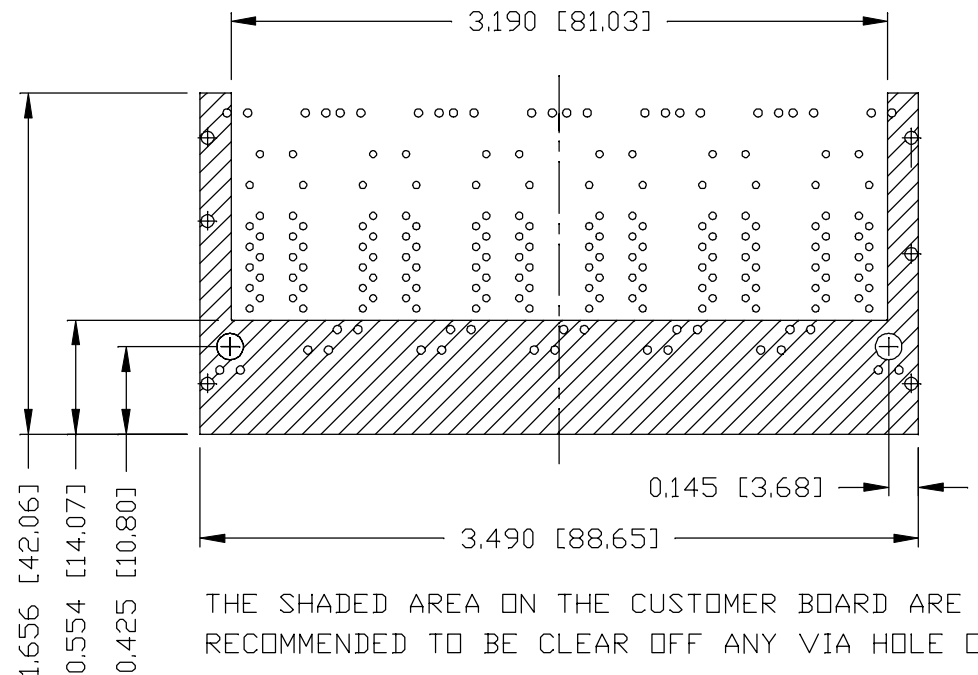

ORIGINATED BY
SANDY LIN
DATE 2019-03-27

DRAWN BY
OLIVER ZHANG
DATE 2019-03-27

TITLE
2X6 gigabit MagJack®
PoEp
(Extended temperature)
08AN-2C6R-GK-C
PATENTED

PART NO. / DRAWING NO.
08AN2C6RGK-C

FILE NAME
08AN2C6RGK-C_B.DWG

STANDARD DIM. TOL. IN INCH	[] METRIC DIM. AS REF.
.X	UNIT : INCH [mm]
.XX	SCALE : N/A
.XXX ±0.004	SIZE : A4

REV. : B PAGE : 4



THE INFORMATION CONTAINED HEREIN IS CONSIDERED "PROPRIETARY" TO BEL FUSE INC. AND SHALL NOT BE COPIED, REPRODUCED OR DISCLOSED WITHOUT THE WRITTEN APPROVAL OF BEL FUSE INC.

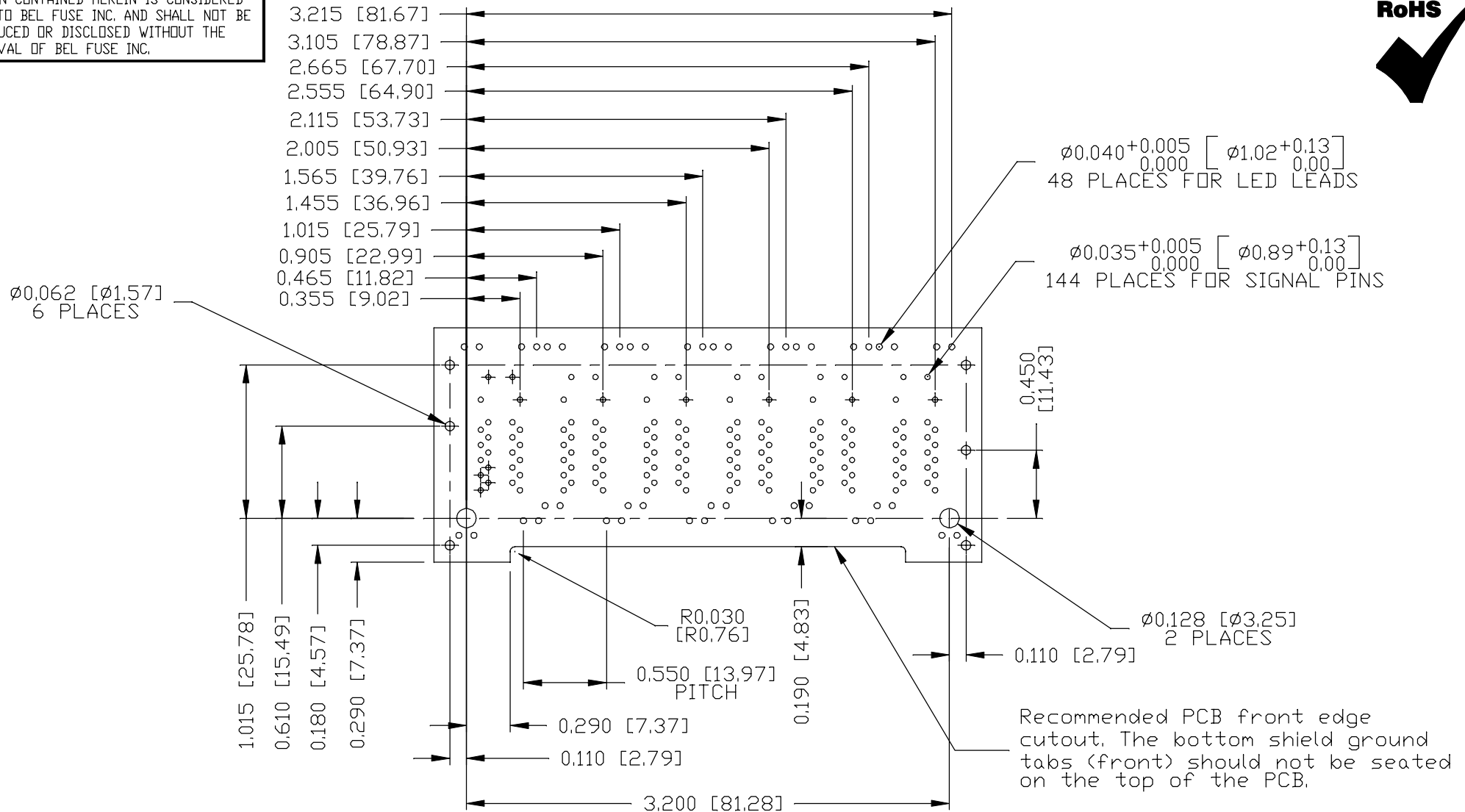

SUGGESTED FOOTPRINT
(COMPONENT SIDE VIEW)

ORIGINATED BY
SANDY LIN
DATE 2019-03-27
DRAWN BY
OLIVER ZHANG
DATE 2019-03-27

TITLE
2X6 gigabit MagJack®
PoEp
(Extended temperature)
08AN-2C6R-GK-C
PATENTED

PART NO. / DRAWING NO.
08AN2C6RGK-C
FILE NAME
08AN2C6RGK-C_B.DWG

STANDARD DIM. TOL. IN INCH	[] METRIC DIM. AS REF.
.X	UNIT : INCH [mm]
.XX	SCALE : N/A
.XXX ±0.004	SIZE : A4

REV. : B PAGE : 5



THE INFORMATION CONTAINED HEREIN IS CONSIDERED "PROPRIETARY" TO BEL FUSE INC. AND SHALL NOT BE COPIED, REPRODUCED OR DISCLOSED WITHOUT THE WRITTEN APPROVAL OF BEL FUSE INC.

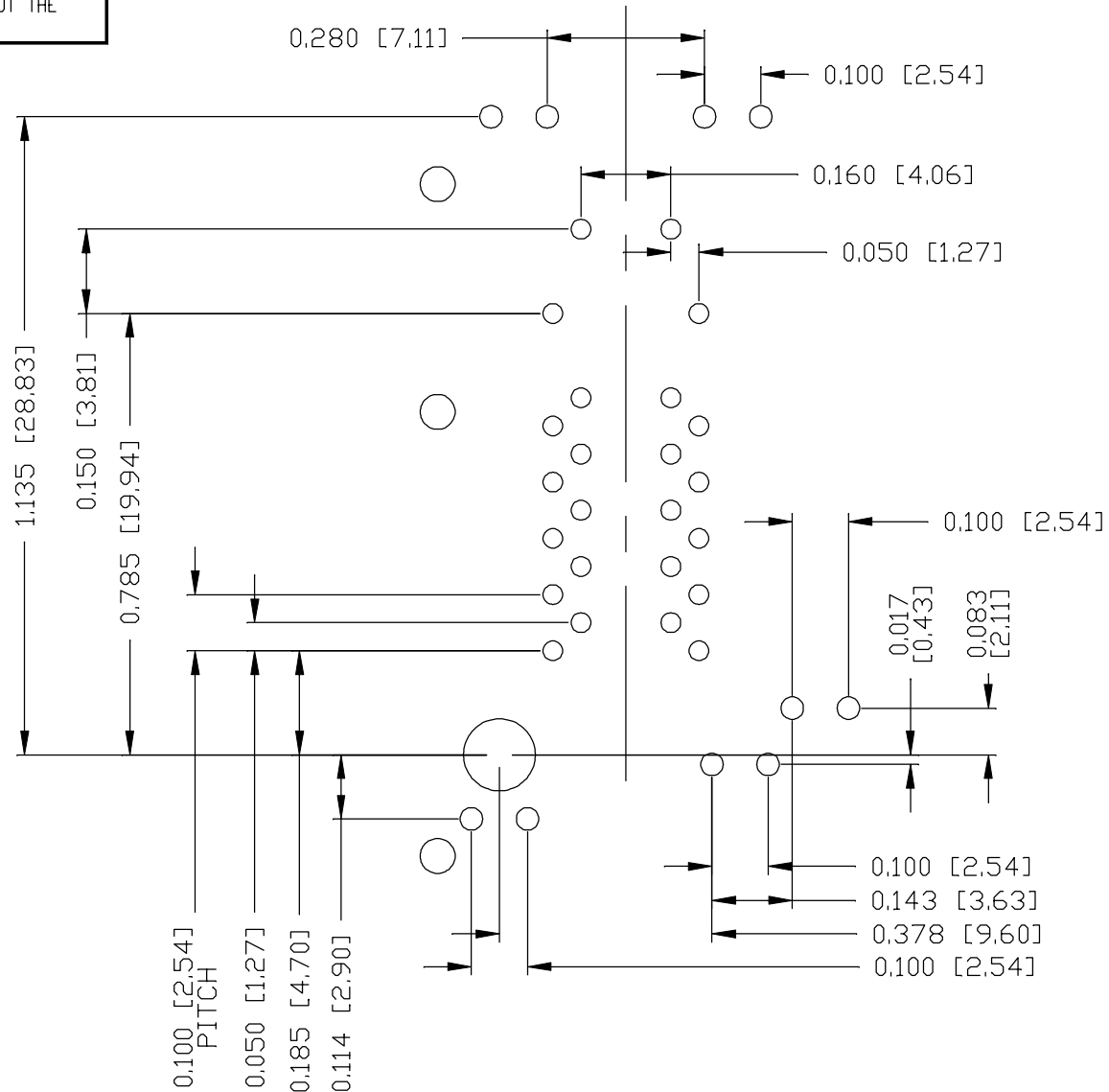

REV. :	B	PAGE :	6
		STANDARD DIM. [] METRIC DIM.	
		TOL. IN INCH AS REF.	
		.X	UNIT : INCH [mm]
		.XX	SCALE : N/A
.XXX	±0.004	⊕	SIZE : A4

ORIGINATED BY
SANDY LIN
DATE 2019-03-27

DRAWN BY
OLIVER ZHANG
DATE 2019-03-27

TITLE
2X6 gigabit MagJack®
PoEp
(Extended temperature)
08AN-2C6R-GK-C
PATENTED

PART NO. / DRAWING NO.
08AN2C6RGK-C

FILE NAME
08AN2C6RGK-C_B.DWG

STANDARD DIM. [] METRIC DIM.
TOL. IN INCH AS REF.

.X UNIT : INCH [mm]
.XX SCALE : N/A
.XXX ±0.004 ⊕ SIZE : A4

THE INFORMATION CONTAINED HEREIN IS CONSIDERED "PROPRIETARY" TO BEL FUSE INC. AND SHALL NOT BE COPIED, REPRODUCED OR DISCLOSED WITHOUT THE WRITTEN APPROVAL OF BEL FUSE INC.



SUGGESTED PANEL OPENING

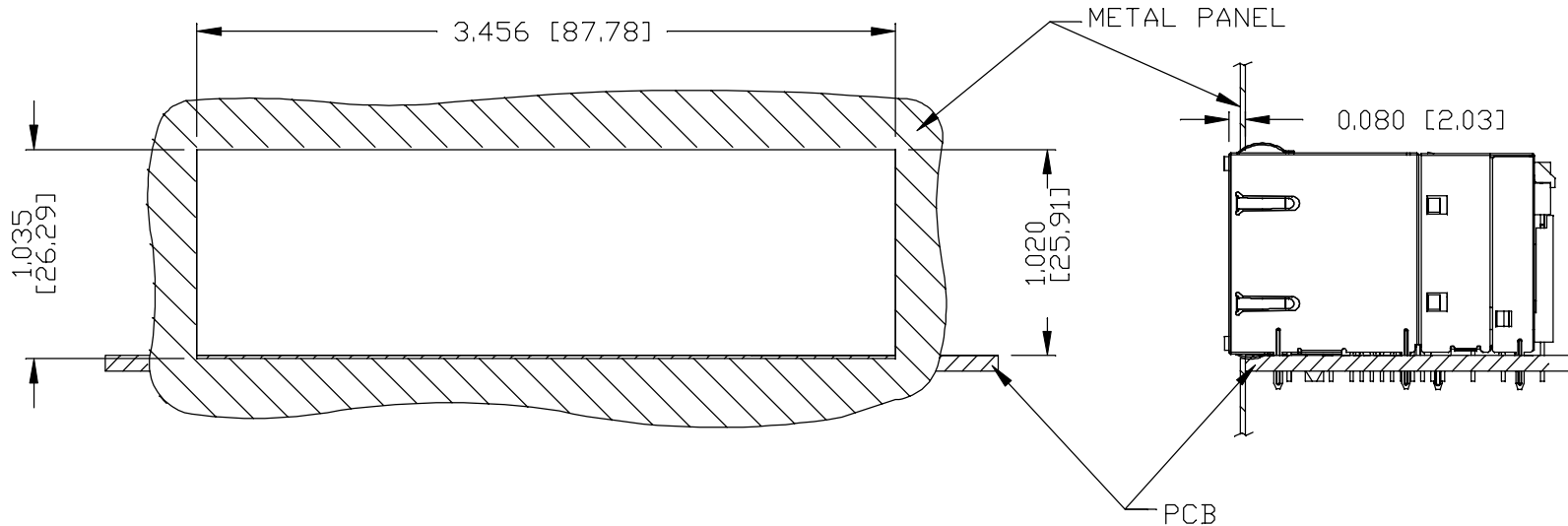

NOTE:

THE DISTANCE OF PANEL INSIDE SURFACE RELATIVE TO FRONT SURFACE OF PART IS ONLY A SUGGESTION. IN CASE THIS DISTANCE IS DIFFERENT, THE REQUIRED PANEL OPENING DIMENSIONS CHANGE ACCORDINGLY.

PACKING INFORMATION

PACKING TRAY : 0200-9999-B7 (TOP)

0200-9999-G6 (BOTTOM)

PACKING QUANTITY : 15 PCS FINISHED GOODS PER TRAY.

5 TRAYS (75 PCS FINISHED GOODS) PER CARTON BOX.

NOTE : CARDBOARDS ARE PLACED BETWEEN LAYERS OF PACKING TRAY INSIDE CARTON BOX.

(INCLUDE THE UPPERMOST AND LOWERMOST TRAY)

REV. : B PAGE : 7

ORIGINATED BY SANDY LIN DATE 2019-03-27	TITLE 2X6 glgablt MagJack® PoEp (Extended temperature) 08AN-2C6R-GK-C PATENTED	PART NO. / DRAWING NO. 08AN2C6RGK-C	STANDARD DIM.		[] METRIC DIM.
			TOL. IN INCH		AS REF.
			.X		UNIT : INCH [mm]
DRAWN BY OLIVER ZHANG DATE 2019-03-27		FILE NAME 08AN2C6RGK-C_B.DWG	.XX		SCALE : N/A
			.XXX	±0.005	SIZE : A4

