

PROTECTION PRODUCTS - RailClamp®

Description

RailClamp® TVS diode arrays are specifically designed to protect sensitive components which are connected to high-speed data and transmission lines from over-voltage caused by **ESD** (electrostatic discharge), **CDE** (Cable Discharge Events), and **EFT** (electrical fast transients).

The unique design incorporates surge rated, low capacitance steering diodes and a TVS diode in a single package. During transient conditions, the steering diodes direct the transient current through the internal TVS diodes safely to ground.

The RClamp®7512N is constructed using Semtech's proprietary EPD process technology. The EPD process provides low operating voltage (2.5V) with significant reductions in leakage current and capacitance over silicon-avalanche diode processes. It features high surge ($I_{pp}=15A$, $t_p=8/20\mu s$) and ESD ($\pm 25kV$ per IEC 61000-4-2) capability with low clamping voltage.

The RClamp7512N is in a SLP3525N12 package. It measures 3.5 x 2.5 x 0.60mm. The leads are finished with lead-free NiPdAu. The flow through design is optimized for use on 2-layer pc boards. Each device will protect up to twelve high-speed lines. The combination of small size, low capacitance, and high ESD and surge capability makes them ideal for use in applications such as next generation color LCD displays and LVDS interfaces.

Features

- ◆ Transient protection for high-speed data lines to **IEC 61000-4-2 (ESD) $\pm 30kV$ (air), $\pm 25kV$ (contact)**
- ◆ **IEC 61000-4-4 (EFT) 40A (5/50ns)**
- ◆ **IEC 61000-4-5 (Lightning) 15A (8/20 μs)**
- ◆ Array of surge rated diodes with internal TVS Diode
- ◆ Flow-Through routing optimized for 2-layer pcb
- ◆ Small package saves board space
- ◆ Protects up to twelve I/O lines
- ◆ Low capacitance (**<5pF**) for high-speed interfaces
- ◆ Low leakage current and clamping voltage
- ◆ Low operating voltage: 2.5V
- ◆ Solid-state silicon-avalanche technology

Mechanical Characteristics

- ◆ SLP3525N12 package
- ◆ Pb-Free, Halogen Free, RoHS/WEEE Compliant
- ◆ Nominal Dimensions: 3.5 x 2.5 x 0.60mm
- ◆ Lead Finish: NiPdAu
- ◆ Molding compound flammability rating: UL 94V-0
- ◆ Marking : Marking code + Date code
- ◆ Packaging : Tape and Reel

Applications

- ◆ TCONN chip Protection
- ◆ 2-Layer PCB
- ◆ LVDS Interfaces
- ◆ LCD TV

Circuit Diagram

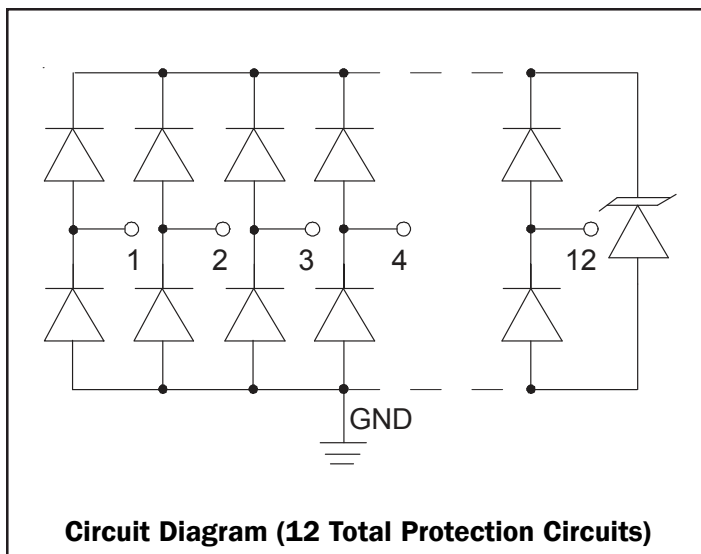

PIN Configuration

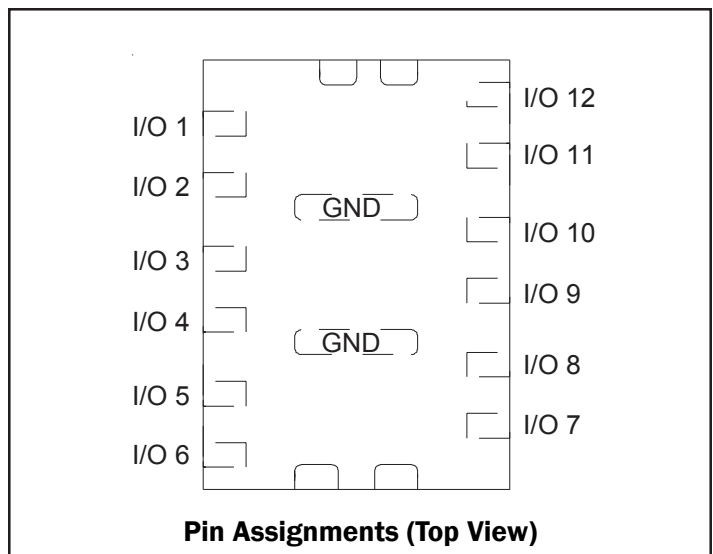

PROTECTION PRODUCTS
Absolute Maximum Rating

Rating	Symbol	Value	Units
Peak Pulse Power ($t_p = 8/20\mu s$)	P_{pk}	135	Watts
Peak Pulse Current ($t_p = 8/20\mu s$) ¹	I_{pp}	15	A
ESD per IEC 61000-4-2 (Air) ESD per IEC 61000-4-2 (Contact)	V_{ESD}	+/-30 +/-25	kV
Operating Temperature	T_J	-55 to +125	°C
Storage Temperature	T_{STG}	-55 to +150	°C

Note: 1) Any I/O to GND

Electrical Characteristics (T=25°C)

Parameter	Symbol	Conditions	Minimum	Typical	Maximum	Units
Reverse Stand-Off Voltage	V_{RWM}				2.5	V
Punch-Through Voltage	V_{PT}	$I_{PT} = 2\mu A$ Any I/O to GND	2.7			V
Snap-Back Voltage	V_{SB}	$I_{SB} = 50mA$ Any I/O to GND	2.0			V
Reverse Leakage Current	I_R	$V_{RWM} = 2.5V, T=25^\circ C$ Any I/O to GND			0.5	μA
Clamping Voltage	V_C	$I_{pp} = 1A, t_p = 8/20\mu s$ Any I/O to GND			4.8	V
Clamping Voltage	V_C	$I_{pp} = 10A, t_p = 8/20\mu s$ Any I/O to GND			7.7	V
Clamping Voltage	V_C	$I_{pp} = 15A, t_p = 8/20\mu s$ Any I/O to GND			9.0	V
Forward Voltage	V_F	$I_{pp} = 10A, t_p = 8/20\mu s$ GND to Any I/O			3.5	V
Forward Voltage	V_F	$I_{pp} = 15A, t_p = 8/20\mu s$ GND to Any I/O			4.8	V
Junction Capacitance	C_j	Between I/O pins and Ground $V_R = 0V - 2.5V, f = 1MHz$			5	pF
		Between I/O pins $V_R = 0V - 2.5V, f = 1MHz$		2.0		pF

PROTECTION PRODUCTS

Typical Characteristics

Non-Repetitive Peak Pulse Power vs. Pulse Time

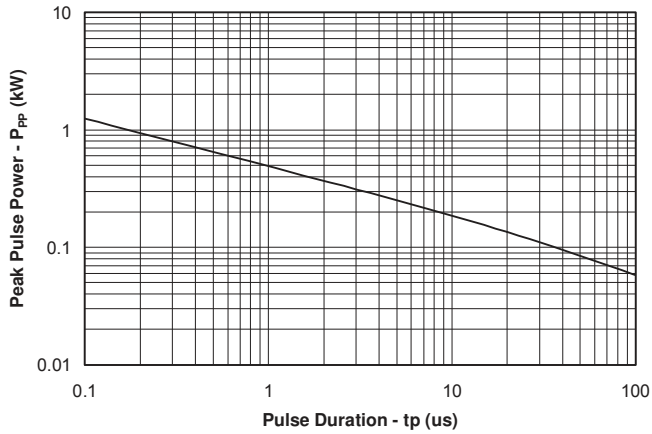

Power Derating Curve

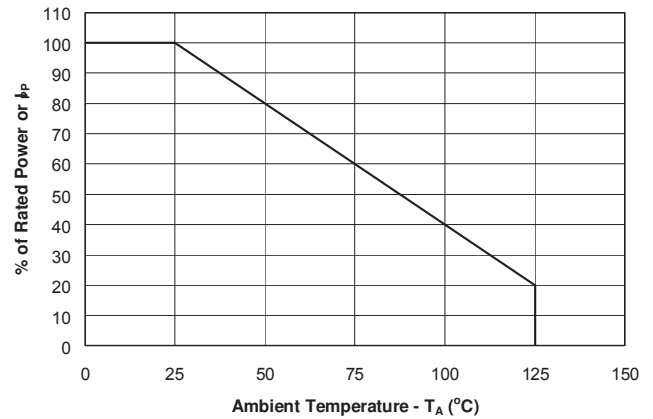

Surge Current Output Waveform ($t_p = 8/20\mu s$)

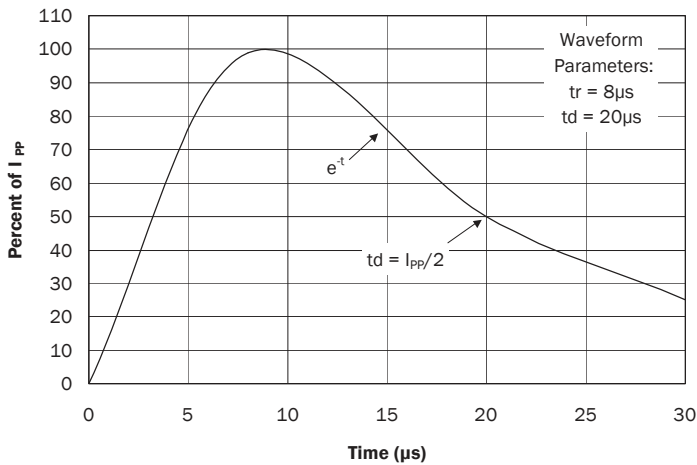

Clamping Voltage vs. Peak Pulse Current Any I/O to GND ($t_p = 8/20\mu s$)

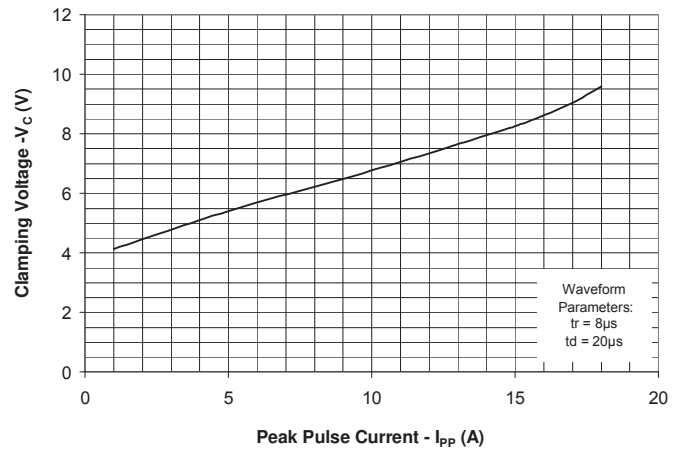

Forward Voltage vs. Peak Pulse Current GND to any I/O ($t_p = 8/20\mu s$)

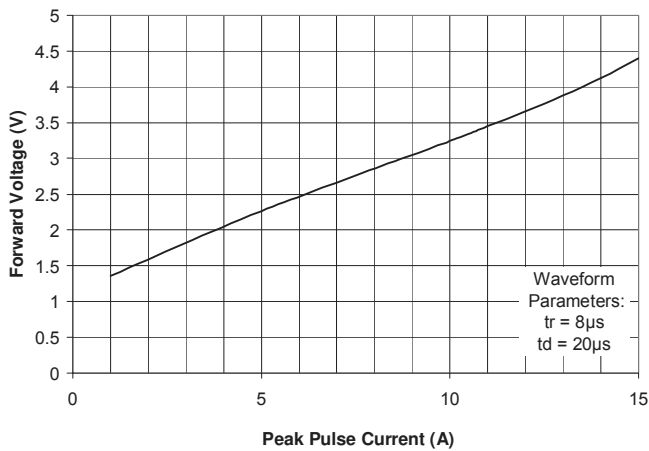

Normalized Capacitance vs. Reverse Voltage (Any I/O to GND)

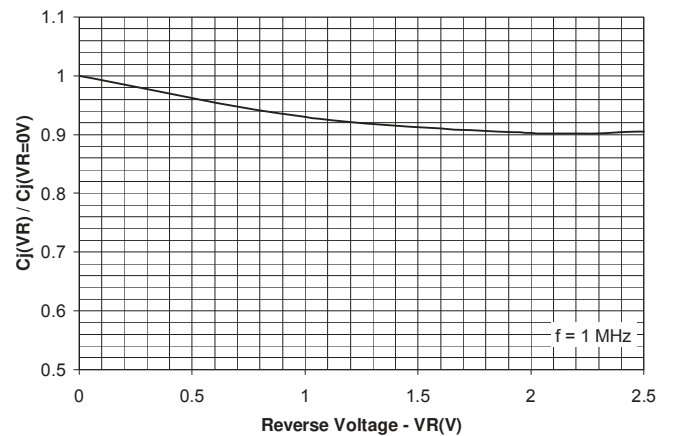

PROTECTION PRODUCTS

Typical Characteristics

Insertion Loss S21 (I/O to Gnd)

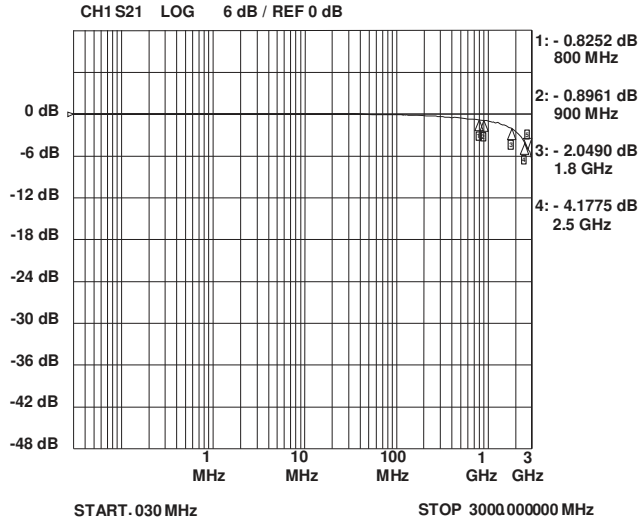

Insertion Loss S21 (I/O to I/O)

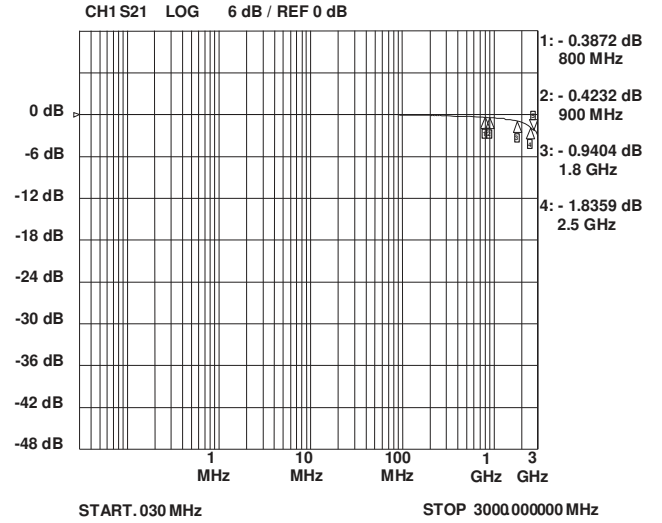

PROTECTION PRODUCTS

Applications Information

Device Connection Options for Protection of Twelve High-Speed Data Lines

This device is designed to protect up to twelve high-speed data lines. It has been optimized for use on LVDS interfaces. The RClamp7512N is constructed using Semtech's proprietary EPD process technology. The EPD process provides low stand-off (turn-on) voltages with significant reductions while maintaining good clamping characteristics and high surge capability. They feature a true operating voltage of 2.5 volts. The characteristics of the RClamp7512N eliminate the need to add an external resistor for protection of LVDS interfaces.

Each pin (1-12) is internally connected to a protection circuit. The pins are slightly staggered to allow clearance for routing traces up to 0.100mm wide with 0.150mm spacing between traces. This flow through design means that the RClamp7512N can be used on PC boards with as few as 2-layers. The device also features two center ground tabs. These pads provide a low inductance path for the surge current to ground. The low inductance ground path is especially critical for reducing the clamping voltage during ESD events.

Pin Configuration (Top View)

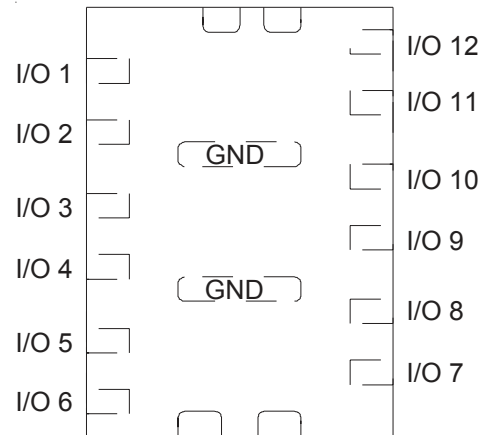

Layout Example

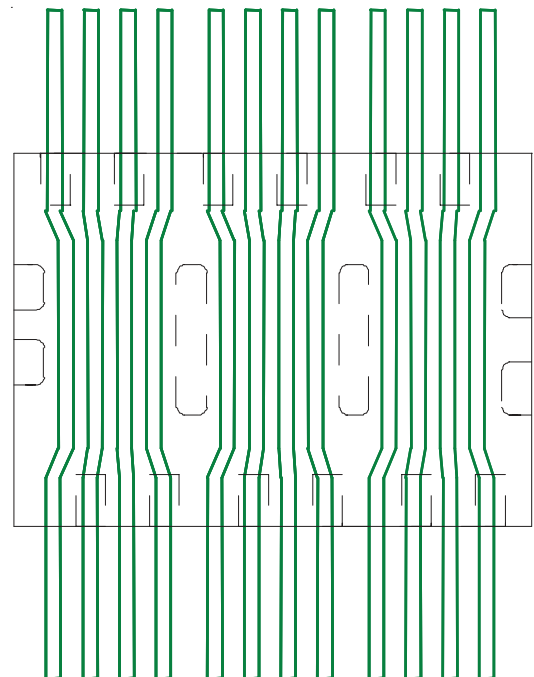

PROTECTION PRODUCTS

Outline Drawing - SLP3525N12

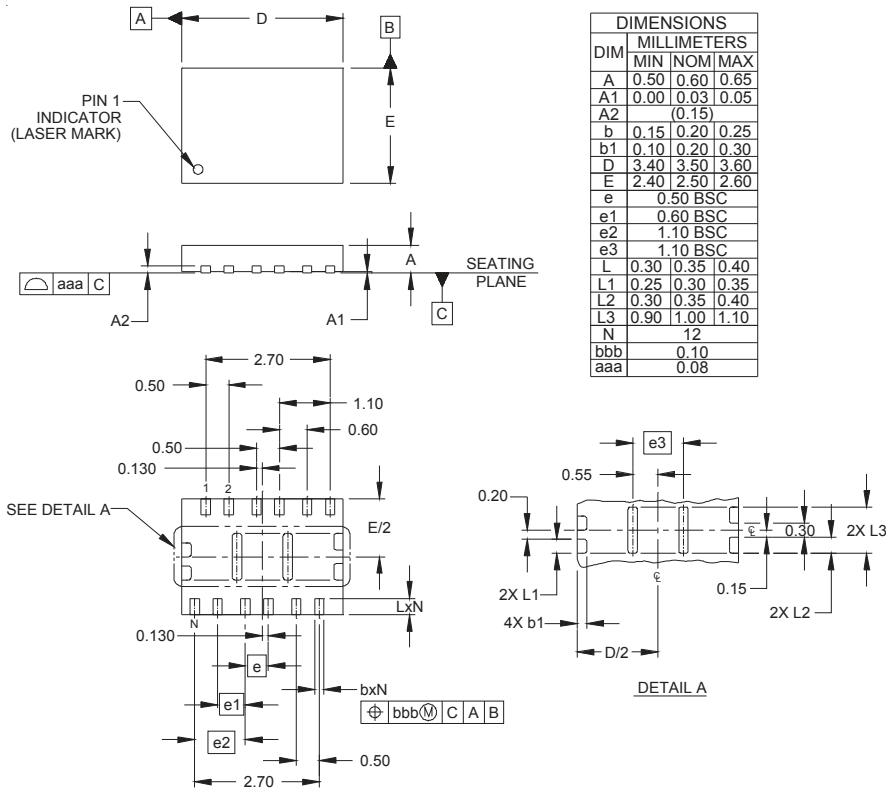

NOTES:
1. CONTROLLING DIMENSIONS ARE IN MILLIMETERS (ANGLES IN DEGREES).

Land Pattern - SLP3525N12

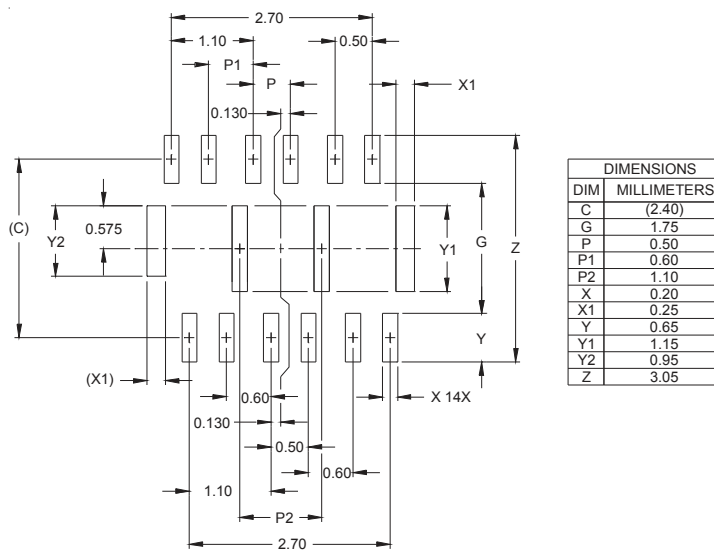

NOTES:
1. CONTROLLING DIMENSIONS ARE IN MILLIMETERS (ANGLES IN DEGREES).
2. THIS LAND PATTERN IS FOR REFERENCE PURPOSES ONLY. CONSULT YOUR MANUFACTURING GROUP TO ENSURE YOUR COMPANY'S MANUFACTURING GUIDELINES ARE MET.

PROTECTION PRODUCTS

Marking

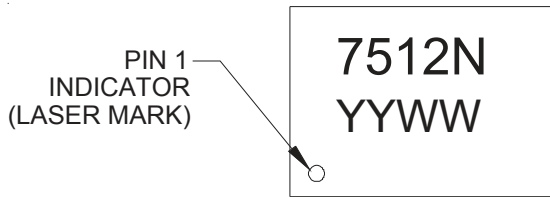

Ordering Information

Part Number	Lead Finish	Qty per Reel	Reel Size
RClamp7512N.TCT	NiPdAu	3000	7 Inch

RailClamp and RClamp are marks of Semtech Corporation

YYWW = Date Code

Tape and Reel Specification

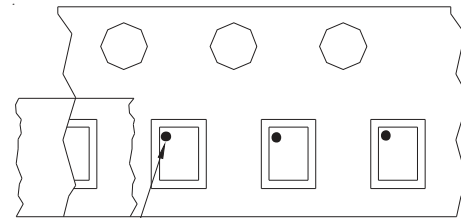
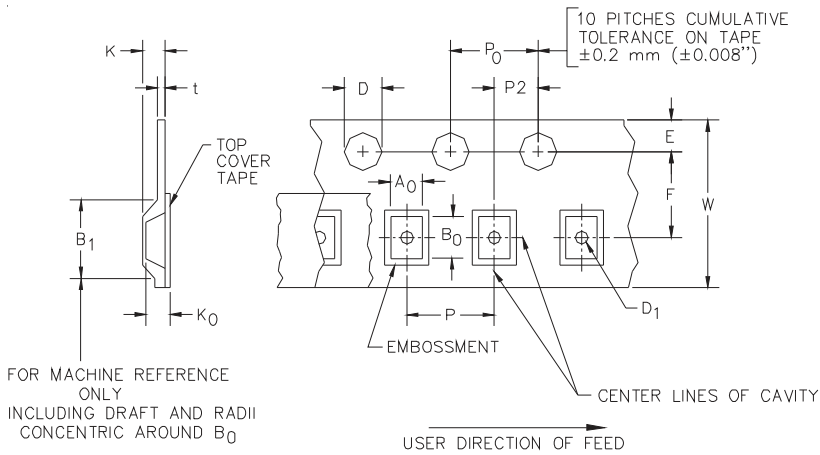

Pin 1 Location

User Direction of feed

Device Orientation in Tape

A0	B0	K0
2.80 +/-0.20 mm	3.80 +/-0.20 mm	0.80 +/-0.10 mm

Tape Width	B, (Max)	D	D1	E	F	K (MAX)	P	P0	P2	T(MAX)	W
12 mm	8.2 mm	1.5 + 0.1 mm - 0.0 mm)	0.5 mm ±0.05	1.750±.10 mm	5.5±0.05 mm	4.5 mm	8.0±0.1 mm	4.0±0.1 mm	2.0±0.05 mm	0.4 mm	12.0 mm ± 0.3 mm

Contact Information

Semtech Corporation
 Protection Products Division
 200 Flynn Rd., Camarillo, CA 93012
 Phone: (805)498-2111 FAX (805)498-3804