

# TLE5045iC

## Technical product description

High End GMR Wheel Speed Sensor, ASIL B(D)

## About this document

### Scope and purpose

High-level description of the product features and technical characteristics as primary information about the functionality of the TLE5045iC High End GMR Wheel Speed Sensor, ASIL B(D)

### Intended audience

Automotive suppliers interested in wheel speed sensor applications

## About this product

### Description

Infineon's TLE5045iC is a wheel speed sensor without direction detection designed for sophisticated vehicle control systems. As the successor of the TLE5041plusC the sensor shows best-in-class jitter performance, thus being the best choice for wheel speed applications. The rotational speed is sensed with high accuracy, enabling the sensor to be used as a component of indirect tire pressure monitoring systems (iTPMS). It is based on integrated giant magneto resistance (iGMR). Excellent sensitivity to magnetic field is specified over a wide temperature range. To meet harsh automotive requirements, robustness to electrostatic discharge (ESD) and electromagnetic compatibility (EMC) was maximized without the need of additional external components.

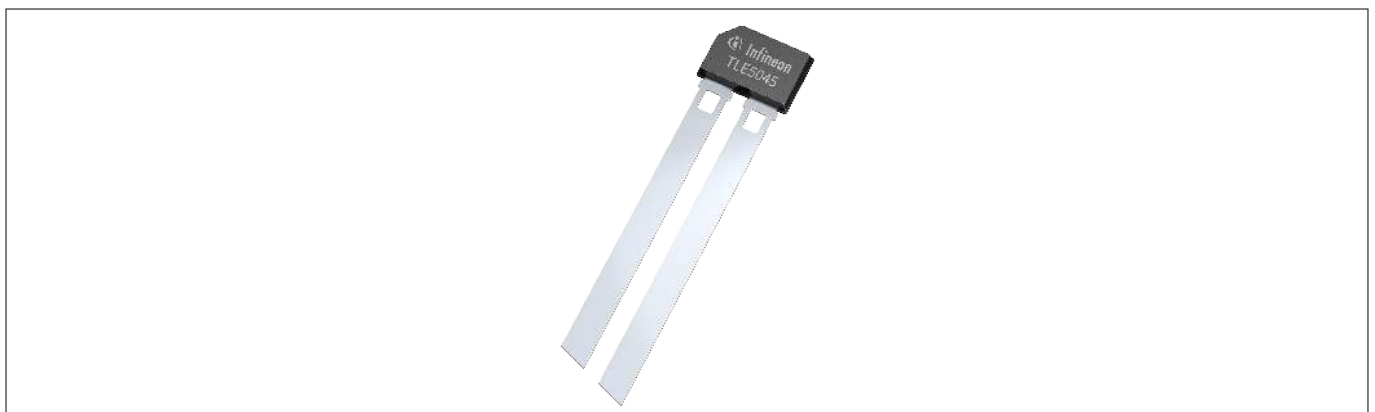

**Figure 1**      **Product photo**

---

## About this product

### Features & Benefits

- Developed according to ISO 26262, compliant with the requirements of ASIL B(D)
- Low jitter 0.02% due to high switching accuracy enables iTPMS
- Two-wire current interface 7mA/14mA providing speed information
- Wide operating junction temperature range -40°C to 190°C
- Robustness against external magnetic disturbances up to 2mT through differential sensing principle
- High sensitivity enables outstanding air gap performance along with immunity against y-displacement effects
- Small sensor package 5x3mm without need of external capacitor saves module size, increases robustness against mechanical stress, and enables design freedom
- Advanced EMC concept maximizes the availability of the sensor signal
- New established Micro Break feature designed to be immune against disturbances on supply line

### Order Information

**Table 1**

<b>Type</b>	<b>Description</b>	<b>Ordering Number</b>
TLE5045iC-R050	Speed only sensor optimized for use with load resistor $R_m \leq 50 \Omega$	SP001649080
TLE5045iC-R100	Speed only sensor optimized for use with load resistor $50 \Omega \leq R_m \leq 100 \Omega$	SP001216864

## Table of contents

	<b>About this document</b> .....	1
	<b>About this product</b> .....	1
<b>1</b>	<b>Product Characteristics</b> .....	4
<b>2</b>	<b>Functional Description</b> .....	6
<b>3</b>	<b>Speed Protocol</b> .....	7
<b>4</b>	<b>Safety Mechanisms</b> .....	7
<b>5</b>	<b>ESD and EMC Characteristics</b> .....	7
<b>6</b>	<b>ESD HBM Model</b> .....	8
<b>7</b>	<b>Product Qualification</b> .....	8
<b>8</b>	<b>Pin Configuration</b> .....	8
<b>9</b>	<b>Package Outline</b> .....	9
<b>10</b>	<b>Terminology</b> .....	10
	<b>Revision history</b> .....	11
	<b>Disclaimer</b> .....	12

## 1 Product Characteristics

### 1 Product Characteristics

#### Absolute Maximum Ratings

Stresses above the maximum values listed here may cause permanent damage to the device.

**Table 2**

Parameter	Symbol	Min.	Typ.	Max.	Unit	Note / Test Condition
Supply voltage	$V_{DD}$	-	-	24	V	max. 30 min @ $T_J = 25 \pm 5^\circ\text{C}$
		-0.6	-	-	V	$T_J < 80^\circ\text{C}$ , $I_{DD}$ reverse current limit applies
Reverse current	$I_{DD}$	-200	-	-	mA	t = max 4 h
Junction temperature	$T_J$	-40	-	190	$^\circ\text{C}$	max 4 h, < 16.5 V
Magnetic flux density	$B_{\text{max}_x}$	-	-	250	mT	max. 1min @ $T_A \leq 85^\circ\text{C}$
	$B_{\text{max}_y}$	-	-			
	$B_{\text{max}_z}$	-	-	500	mT	max. 1min @ $T_A \leq 85^\circ\text{C}$

#### Operating Range

The following operating conditions must not be exceeded in order to ensure correct operation.

**Table 3**

Parameter	Symbol	Min.	Typ.	Max.	Unit	Note / Test Condition
Supply voltage	$V_{DD}$	5.2	-	20	V	TLE5045iC-R100
	$V_{DD}$	4.25	-	20	V	TLE5045iC-R050
Operating Temperature	$T_J$	-40		190	$^\circ\text{C}$	
Magnetic signal frequency	$f_{\text{mag}}$	0.03	-	3000	Hz	
Minimum differential magnetic input signal amplitude, magnetic encoder application	$\text{dB}_{\text{limit}_x}$ $T_A = 25^\circ\text{C}$	70	90	110	$\mu\text{T}$	99% criterium
Magnetic induction amplitude at each GMR sensing element	$B_x$	-25	-	25	mT	
Dynamic and static homogeneous external disturbance fields	$B_{\text{ext}_{XYZ}}$	-2		2	mT	no unwanted pulses

## 1 Product Characteristics

### Functional Parameters

The magnetic input is assumed sinusoidal with constant amplitude and offset. The typical values shown below are valid for  $V_{DD} = 12\text{ V}$  and  $T_A = 25^\circ\text{C}$ . For a more detailed specification please refer to our product datasheets which are available on request.

**Table 4**

Parameter	Symbol	Min.	Typ.	Max.	Unit	Note / Test Condition
Period jitter	$S_{jit}$	-	$\pm 0.02$		%	$\pm 1\sigma$ value
Duty cycle	DC	40	-	60	%	in calibrated mode
Supply current during static output low state	$I_{low}$	5.95	7	8.05	mA	
Supply current during static output high state	$I_{high}$	11.9	14	16.1	mA	
Current level for indicating errors	$I_{Error}$	1	3.5	3.8	mA	
Output current slew rate	$SR_r, SR_f$	11	-	28	mA/ $\mu\text{s}$	$SR_r = (I_{90\%} - I_{10\%}) / t_r$ $SR_f = (I_{90\%} - I_{10\%}) / t_f$
Switch-off voltage	$V_{reset}$			3.5	V	direct on sensor pins
Supply voltage hysteresis	$V_{Hys}$	1.5		1.7	V	TLE5045iC-R100
Supply voltage hysteresis	$V_{Hys}$	0.65		0.75	V	TLE5045iC-R050

**2 Functional Description**

**2 Functional Description**

The sensor element has a magnetic interface to detect the increments of a magnetized encoder: the sensing principle is based on the giant magneto resistance (GMR) principle sensitive to magnetic fields in x-direction. It is designed for maximum sensitivity and suppression of homogeneous fields.

In the figure below the typical placement of the TLE5045iC facing a magnetic encoder wheel is shown. The figure also indicates the coordinate system, which is valid throughout this document.

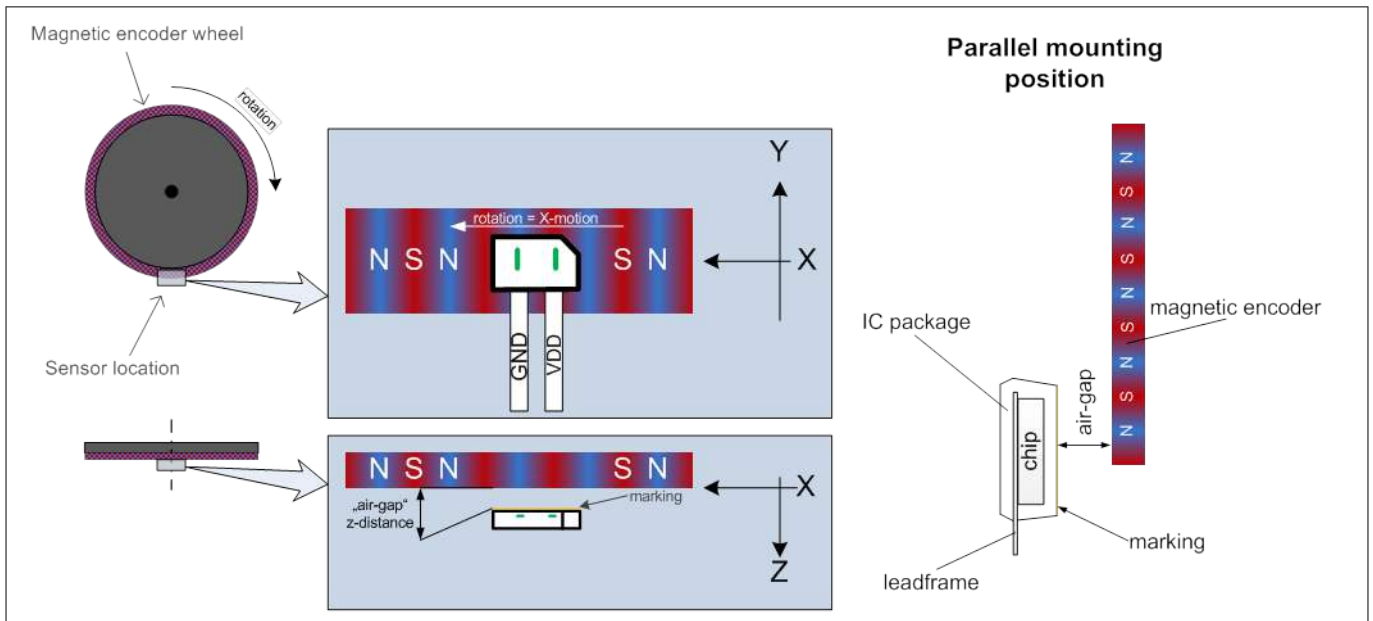
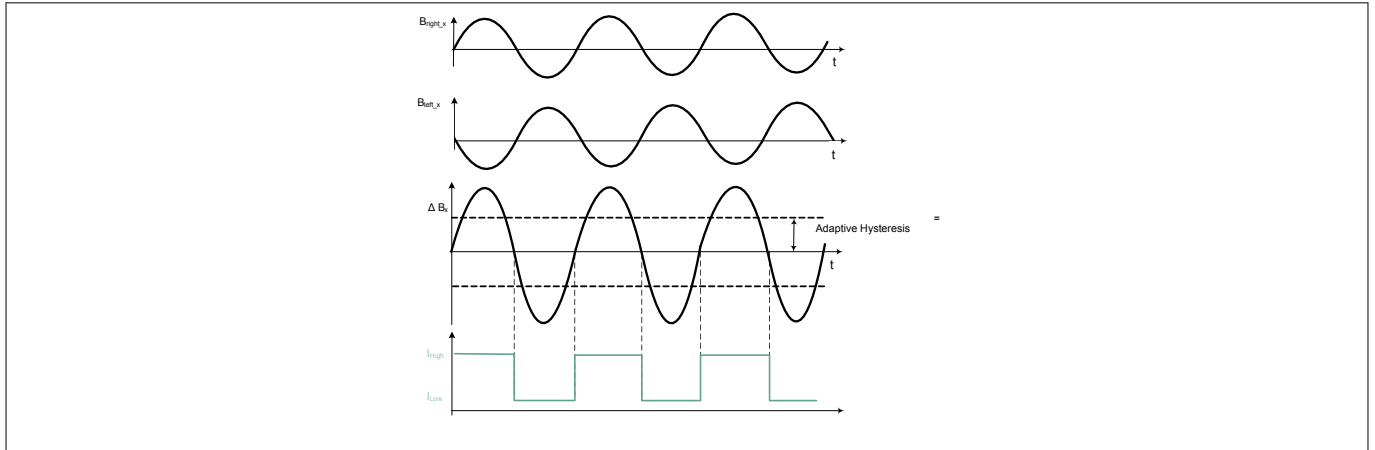

**Figure 2** Typical placement of the TLE5045iC

**3 Speed Protocol**

**3 Speed Protocol**

The first output pulse is generated when the input field exceeds the minimal magnetic threshold  $2 \times dB_{limit}$ . After minimum and maximum are detected and offset is compensated, output switching occurs at zero-crossing of the differential magnetic signal.



**Figure 3** Signal output pulse

**4 Safety Mechanisms**

The TLE5045iC offers safety features to support the Automotive Safety Integrity Level ASIL B and is designed to be used in ASIL D systems.

An embedded safety concept was developed to notify the Control System in case of an internal error by setting the output current level to a constant failure indication level  $I_{Error}$ .

Following safety mechanisms have been implemented:

- Undervoltage detection: This safety mechanism detects voltage drops to values where the correct functionality of the circuitry is no more ensured. The sensor remains in this state until the error condition is solved and  $V_{DD}$  is back into normal operating range.
- Detection of discrepancy between number of active fuses and internally stored number of fuses: This safety mechanism compares the active fuse bits against the internal stored quantity. The sensor remains in this failure indication state  $I_{Error}$  until the device is powered off and on again and the error condition is not present any longer.

The entirety of Infineon experience has been used to identify and prevent common cause of failure in the application including EMC disturbances and mechanical tolerances. An advanced EMC concept, inclusive of microbreak feature, without the need of external components, maximizes the availability of the sensor signal at the electrical interface. Also, the speed algorithm is designed for fast start-up and optimization of duty cycle. The extremely low jitter of the sensor contributes to high time accuracy of the speed signal.

TLE5045iC is accompanied by accurate safety analysis and complete documentation to enable the system integrator to quickly evaluate the compatibility with the system/item and start the integration process. A detailed description of how the sensor is to be used in an ISO26262 compliant system can be found in the Safety Manual and Safety Analysis Summary Report, which are available on request.

**5 ESD and EMC Characteristics**

The TLE5045iC is characterized according to the IC level EMC requirements described in the “Generic IC EMC Test Specification” Version 2.0 from 2014. EMC testreport is available on request.

**6 ESD HBM Model**

Additionally component level EMC characterizations are performed according to ISO 7637-2:2011, ISO 7637-3:2007 and ISO 16750-2:2010 regarding pulse immunity, and CISPR 25 (2009-01) Ed. 3.0 regarding conducted emissions.

**6 ESD HBM Model**

**Table 5**

Parameter	Symbol	Min.	Typ.	Max.	Unit	Note / Test Condition
ESD Voltage	$V_{HBM}$	-	-	$\pm 12$	kV	Method AEC-Q100 Rev H (1.5 k $\Omega$ , 100 pF)

**7 Product Qualification**

Product qualification according to AEC-Q100 Grade 0 is performed.

**8 Pin Configuration**

**Table 6**

Pin No.	Symbol	Function
1	VDD	Supply voltage
2	GND	Ground

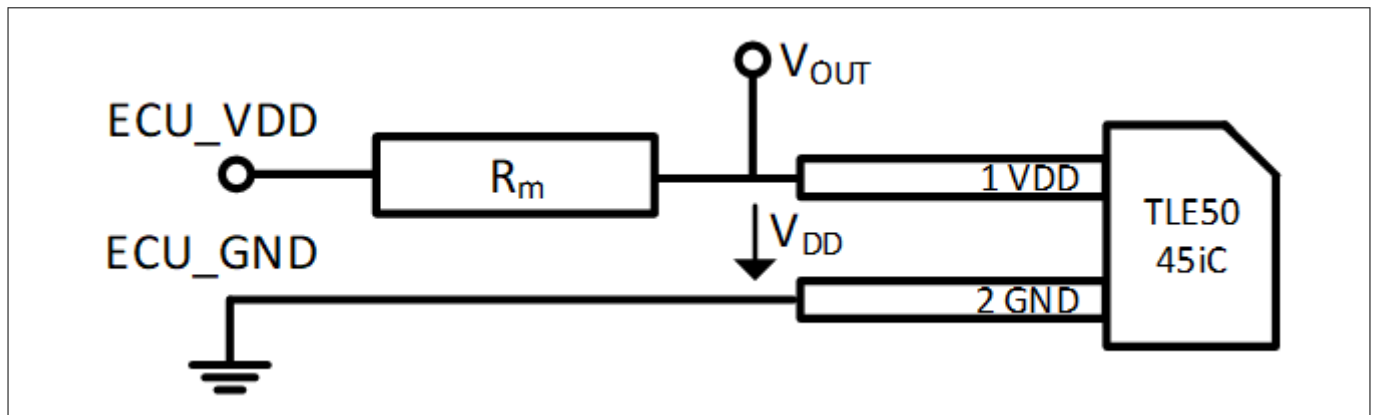

**Figure 4 Pin configuration**



## 9 Package Outline

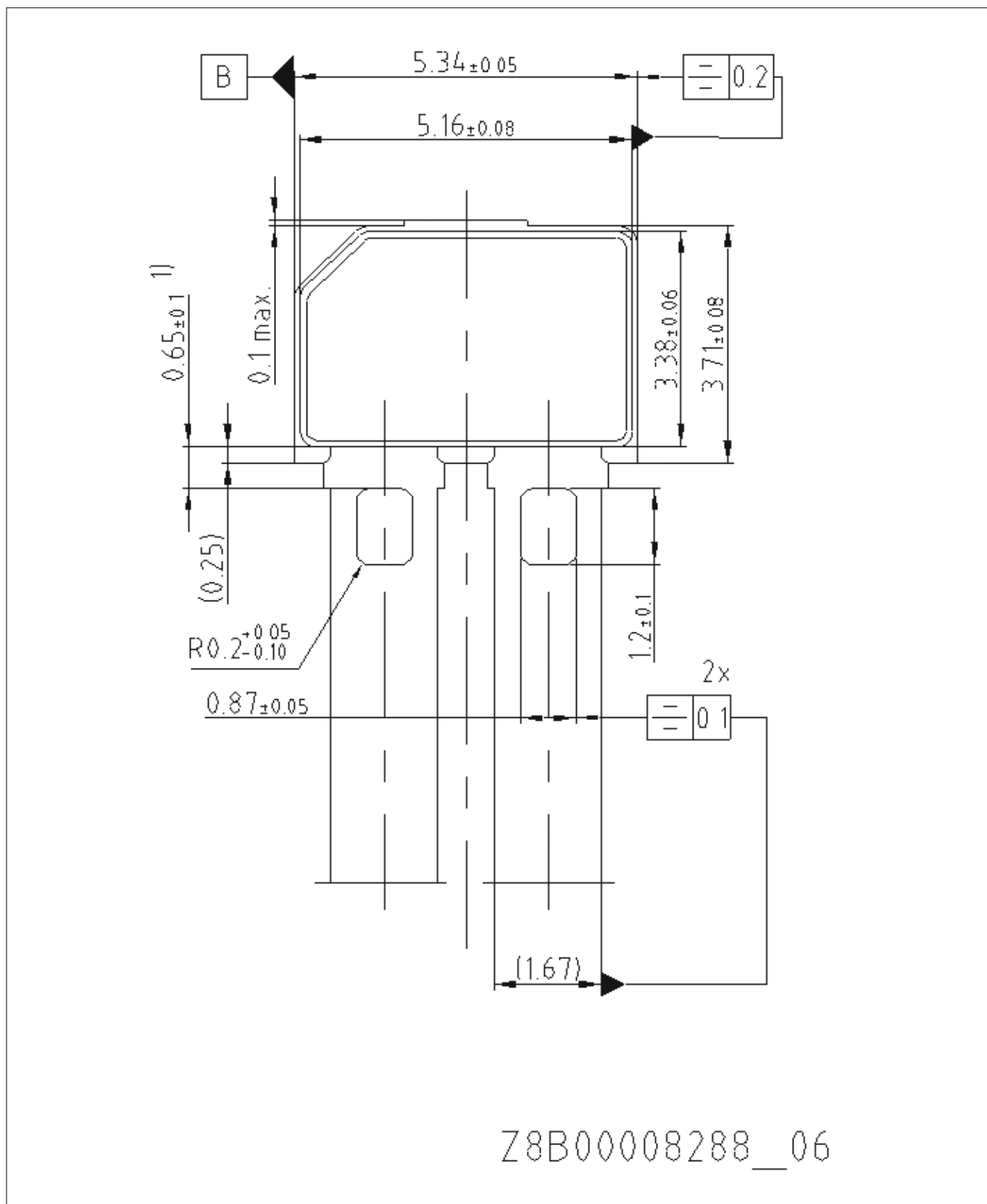

Figure 5 Package Outline

**10 Terminology**

**10 Terminology**

**Table 7**

μs	microsecond
μT	micro-Tesla
A	Ampere
AEC	Automotive Electronics Council
AK	Arbeitskreis
ASIC	application specific integrated circuit
ASIL	automotive safety integrity Level
C	Celsius
CISP	Comité international spécial des perturbations radioélectriques
EMC	electromagnetic compatibility
ESD	electrostatic discharge
GMR	giant magneto resistance
GND	ground
h	hour
HBM	human body model
Hz	Hertz
IC	integrated circuit
iGMR	integrated giant magneto resistance
ISO	International Organization for Standardization
iTPMS	integrated tire pressure monitoring system
kΩ	kilo-Ohm
kV	kilo-Volt
mA	milli-Ampere
min	minute
mm	millimeter
ms	millisecond
mT	milli-Tesla
Ω	Ohm
pF	picofarad
PWM	pulse width modulation
V	Volt
VDD	supply voltage

---

**Revision history**

## **Revision history**

<b>Document version</b>	<b>Date of release</b>	<b>Description of changes</b>
1.0	2018-11-06	<ul style="list-style-type: none"><li>Initial version</li></ul>

## Trademarks

All referenced product or service names and trademarks are the property of their respective owners.

**Edition 2018-11-06**

**Published by**  
**Infineon Technologies AG**  
**81726 Munich, Germany**

**© 2018 Infineon Technologies AG**  
**All Rights Reserved.**

**Do you have a question about any**  
**aspect of this document?**  
**Email: [erratum@infineon.com](mailto:erratum@infineon.com)**

**Document reference**  
**IFX-srj1538755497187**

## IMPORTANT NOTICE

The information given in this document shall in no event be regarded as a guarantee of conditions or characteristics ("Beschaffheitsgarantie").

With respect to any examples, hints or any typical values stated herein and/or any information regarding the application of the product, Infineon Technologies hereby disclaims any and all warranties and liabilities of any kind, including without limitation warranties of non-infringement of intellectual property rights of any third party.

In addition, any information given in this document is subject to customer's compliance with its obligations stated in this document and any applicable legal requirements, norms and standards concerning customer's products and any use of the product of Infineon Technologies in customer's applications.

The data contained in this document is exclusively intended for technically trained staff. It is the responsibility of customer's technical departments to evaluate the suitability of the product for the intended application and the completeness of the product information given in this document with respect to such application.

## WARNINGS

Due to technical requirements products may contain dangerous substances. For information on the types in question please contact your nearest Infineon Technologies office.

Except as otherwise explicitly approved by Infineon Technologies in a written document signed by authorized representatives of Infineon Technologies, Infineon Technologies' products may not be used in any applications where a failure of the product or any consequences of the use thereof can reasonably be expected to result in personal injury