

# MODELS

## SFN08A, SFN08B

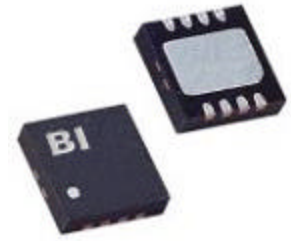

Isolated and bussed circuits  
Thin film resistor network  
RoHS compliant available

### FEATURES

Precision Nichrome Resistors on Silicon	Passivation coating provides protection in humid environments
Industry Standard Packaging	8 pad SON <sup>1</sup> 4mm square with 0.8 mm pitch (JEDEC MO-229D)
Ratio Tolerances	< ± 0.05%
TCR Tracking Tolerances	< ± 5 ppm/°C

### SCHEMATICS

A Circuit - Isolated Resistors

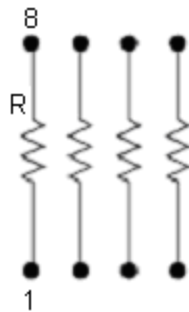

B Circuit - Bussed Resistors

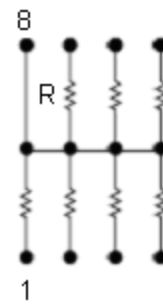

### ELECTRICAL<sup>2</sup>

Standard Resistance Range <sup>3</sup>	1K ohms to 100K ohms (Isolated) 1K ohms to 30K ohms (Bussed)
Resistor Tolerances	± 0.25%
Ratio Tolerances	± 0.05%
TCR	Reference TCR table
Operating Temperature Range	-55°C to +125°C
Interlead Capacitance	< 2 pF
Insulation Resistance	= 10,000 Megohms
Maximum Operating Voltage	100 Vdc or v PR
Noise, Maximum (MIL-STD-202, Method 308)	-25 dB
Resistor Power Rating at 70°C	0.1 Watts

<sup>1</sup> Small outline no lead (SON) package is also referred to as quad flat no lead (QFN) or dual flat no lead (DFN) packages.

<sup>2</sup> Specifications subject to change without notice.

<sup>3</sup> E96 codes available.

**PACKAGE POWER, WATTS @70°C<sup>4</sup>**

SFN08

0.4

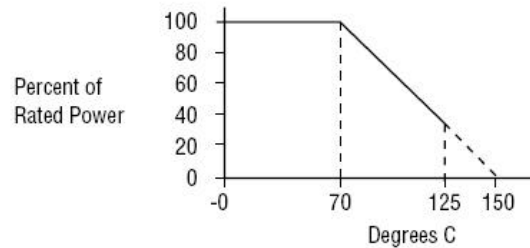
**POWER DERATING CURVE****ENVIRONMENTAL (MIL-R-83401)**

Thermal Shock plus Power Conditioning	ΔR 0.25%
Short Time Overload	ΔR 0.1%
Terminal Strength	ΔR 0.1%
Moisture Resistance	ΔR 0.2%
Mechanical Shock	ΔR 0.25%
Vibration	ΔR 0.25%
Low Temperature Operation	ΔR 0.05%
High Temperature Exposure	ΔR 0.1%
Resistance to Solder Heat	ΔR 0.1%
Marking Permanency	Per MIL-STD-202, Method 215
Flammability	UL-94V-0 Rated
Storage Temperature Range	-55°C to +125°C

**MECHANICAL**

Pad Plating	80/20 Tin Lead (non-RoHS compliant) 100 matte Tin (RoHS compliant)
Pad Material	Copper Alloy
Pad Coplanarity	0.003" (0.08 mm)
Substrate Material	Silicon
Resistor Material	Passivated Nichrome
Body Material	Molded Epoxy

<sup>4</sup> Maximum power per resistor @ 70°C is 100 mW, not to exceed package power.

**ORDERING INFORMATION<sup>5</sup>**

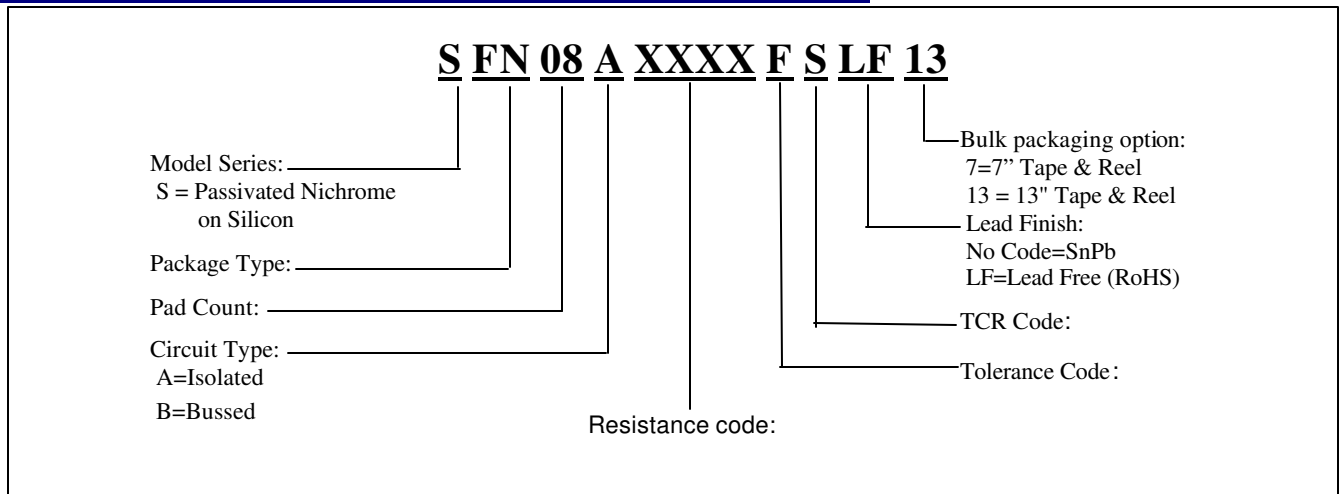

**PACKAGE TYPE**

	Package Codes	Package Size	Pad count	Mechanical Outline
SON	FN	4mm x 4mm	8	MO-229D

**RESISTANCE**

First 3 digits are significant. Fourth digit denotes number of trailing zeros. For values less than 100, use "R" to denote a decimal point. Example, 51 and 10000 ohms are coded as 51R0 and 1002 respectively. Standard values follow E96.

**RESISTANCE TOLERANCE**

Accuracy Code at 25°C	CB	D	FA	F	G	J
Absolute Resistance Tolerances (%)	± 0.25	± 0.5	± 1.0	± 1.0	± 2.0	± 5.0
Ratio Tolerances (R1 Ref) (%)	± 0.1	± 0.1	± 0.05	± 1.0	N/A	N/A

**TEMPERATURE COEFFICIENT OF RESISTANCE (TCR)**

TCR Code (-55°C to 125°C)	Q	P	S	L
Absolute (ppm/°C)	± 25	± 50	± 100	± 200
Tracking (R1 Ref) (ppm/°C)	± 5	± 5	N/A	N/A

**BULK PACKAGING OPTIONS**

Model + Pad Count	Quantity	
	7" Reel	13" Reel
SFN08	1000	3000

<sup>5</sup> Contact customer service for custom designs and features.