

ROD GUIDES

Zinc-plated steel supplied with steel seeger.

TOOTHED WHEEL

Zinc alloy with superficial chromate treatment.

STANDARD EXECUTIONS

- **CAR-M-347**: nickel-plated zinc alloy.
- **CAR-TP-347**: glass-fibre reinforced polyamide based (PA) technopolymer.

ACCESSORIES ON REQUEST

Rod control CAR. are used in combination with latches with handles CLT. (see page 1558) to be ordered separately (see the assembly drawing).

Other accessories available on request:

- black technopolymer rod guides: one rod guide every 500 mm of rod control (code 421133 C.GAT);
- 2 flat galvanised steel rod guides, section 14x3 mm, length 1.000 mm and black technopolymer edge rolls for frame 20 mm thick (code 421135 C.AT 1000-20);
- 2 flat galvanised steel rod guides, section 14x3 mm, length 1.000 mm and black technopolymer edge rolls for frame 25 mm thick (code 421136 C.AT 1000-25).

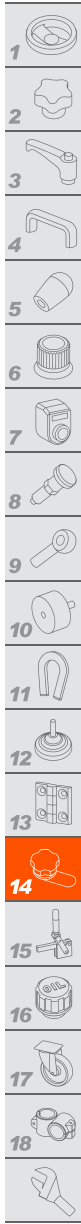
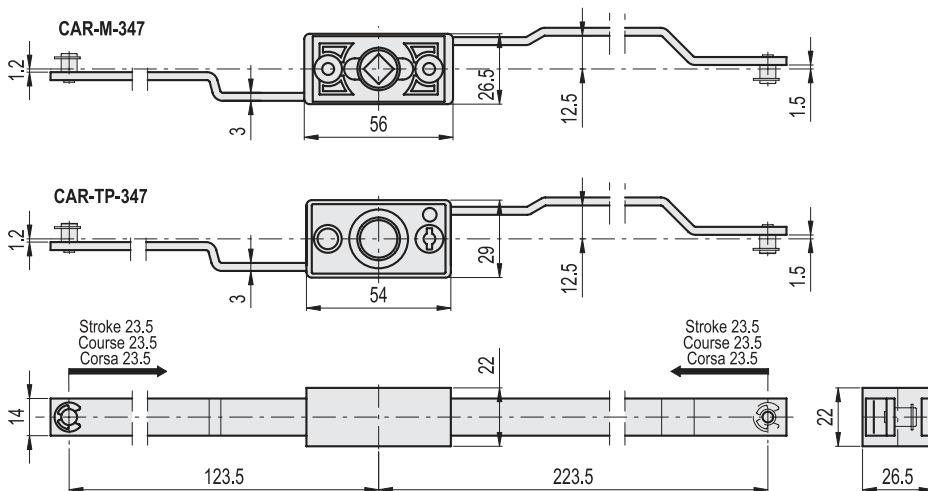
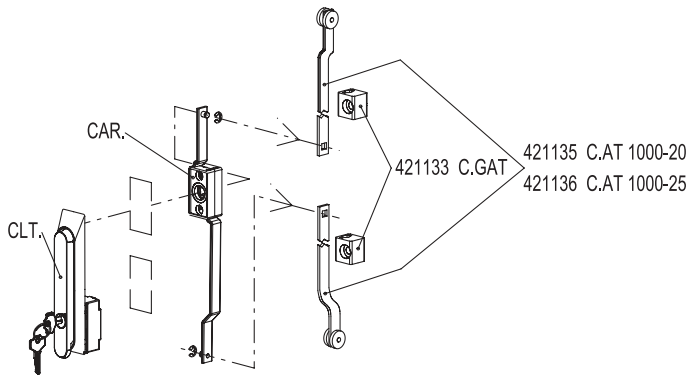

METRIC

| Code | Description | △△ |
|--------|-------------|-----|
| 420031 | CAR-M-347 | 210 |
| 420032 | CAR-TP-347 | 150 |

Latches