

ITEM NUMBER	TE PART NUMBER	DESCRIPTION	QTY PER KIT
1	1055439-1	Cable Fixture Sub-Assembly	1
2	1055441-1	Clamp Insert for 2.16 [.085] Cable	1 Set
3	1055540-1	Clamp Insert for 3.58 [.141] Cable	1 Set
4	91362-1	0.38 [.015] Thick Solder Gage	1
5	1055470-1	Locator Tool	1
6	1055471-1	Locator Tool	1
7	1055472-1	Center Contact Holder	1
8	1055473-1	Dielectric Insert Tool	1

Figure 1

## 1. INTRODUCTION

Solder Assembly Kit 1055468-1, shown in Figure 1, for Type N Connectors contains everything necessary to solder Type N solder-style connectors to 2.16 [.085] and 3.58 [.141] diameter semi-rigid cable.



*Tool directions in this document are for reference only. Refer to the appropriate connector assembly instructions to insure proper assembly. Refer to Figure 2 for connector assemblies and their associated instruction sheets.*



*Dimensions are in metric units [with U.S. customary units in brackets], unless otherwise indicated.*

Contact customer service or refer to Catalog 1307191 for additional information.

## 2. DESCRIPTION

Solder Assembly Kit 1055468-1 contains the tooling required to properly solder Type N connectors to semi-rigid coax cable. The kit contains a cable fixture sub-assembly, two sets of clamp inserts for 2.16 [.085] and 3.58 [.141] cable, and two types of locators that are used to properly align the connector and cable. The kit also contains a solder gage for proper spacing of the center contact, a center contact holder, and a dielectric insertion tool.

SEMI-RIGID CABLE APPLICATIONS	
Connector Part Number	Instruction Sheet
1057165-1	408-4744
1057176-1	408-4884
1057154-1	408-4903
1093513-1	408-4905
1057174-1	408-4908
1057175-1	408-4909
1057085-1 1057087-1	408-4910
1057160-1	408-4911
1057119-1 1057178-1	408-4912
1057116-1	408-4913
1057094-1	408-4914
1057088-1	408-4915
1058628-1	408-8243
1058627-1	408-8245

Figure 2

The cable fixture subassembly consists of a fixture frame, thumbscrew, positioning tool and spring. See Figure 3. When used with the proper clamp inserts the assembly holds and locates coaxial cable for soldering.

### 3. INSTALLING/REPLACING THE CLAMP INSERT

**NOTE**  *Clamp inserts come in sets of two. Upper and lower inserts are interchangeable.*

1. Select the appropriate clamp inserts. Refer to Figure 1 for the appropriate clamp inserts.
2. Remove the cable fixture thumbscrew by rotating it in a counterclockwise direction.
3. Remove the positioning tool by rotating it in a counterclockwise direction.
4. Remove the clamp inserts from the frame after the positioning tool is removed.
5. Sandwich the spring in the pockets on the replacement clamp inserts.
6. Place clamp inserts in the fixture frame and reinstall the positioning tool.
7. Retighten positioning tool.
8. Reinstall the thumbscrew.

### 4. TRIMMING CABLE WITH FIXTURE FRAME

The fixture frame is equipped with six trimming holes designed to remove the outer jacket and cable dielectric. The side marked with the number 2 is for trimming 1.78 [.070], 2.16 [.085], and 3.58 [.141] cable. See Figures 3 and 4. When cable is fully bottomed during trimming, a strip length of 2.79 [.110] will result. If different strip lengths are required the center conductor must be trimmed separately.

The side marked with a number the number "1" is for trimming cable already mounted in a connector housing. See the connector specific instruction sheet for more information.

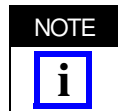

*Trim blades are NOT included with the kit. Use a razor blade with 0.38 [.015] maximum thickness.*

### 5. USING SOLDER GAGE AND CENTER CONTACT HOLDER

The center contact holder is designed to hold both male and female center contacts for the Type N connectors.

The solder gage is used to properly space the Type N center contact away from the cable dielectric. Refer to the connector specific instruction sheet for the appropriate solder gage to be used during the assembly procedure.



*Center contact holders contains small amounts of lead. The lead is used for assembly.*

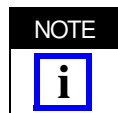

*Maximum operating temperature for the center contact holder is 300°C [572°F]*



*To avoid personal injury, be sure to observe all local safety practices (including the use of gloves). The solder gage, center contact holder, and the contact may be hot after soldering.*

### 6. USING LOCATING TOOLS

Solder Assembly Kit 1055468-1 contains two locating tools. Refer to the connector specific instruction sheet for selection of proper locator tool and assembly instructions.

These tools are designed to be used with the fixture subassembly. To insure proper connector assembly, follow the instructions listed below.

1. Place connector housing on end of cable subassembly. The subassembly refers to cable with center contact.

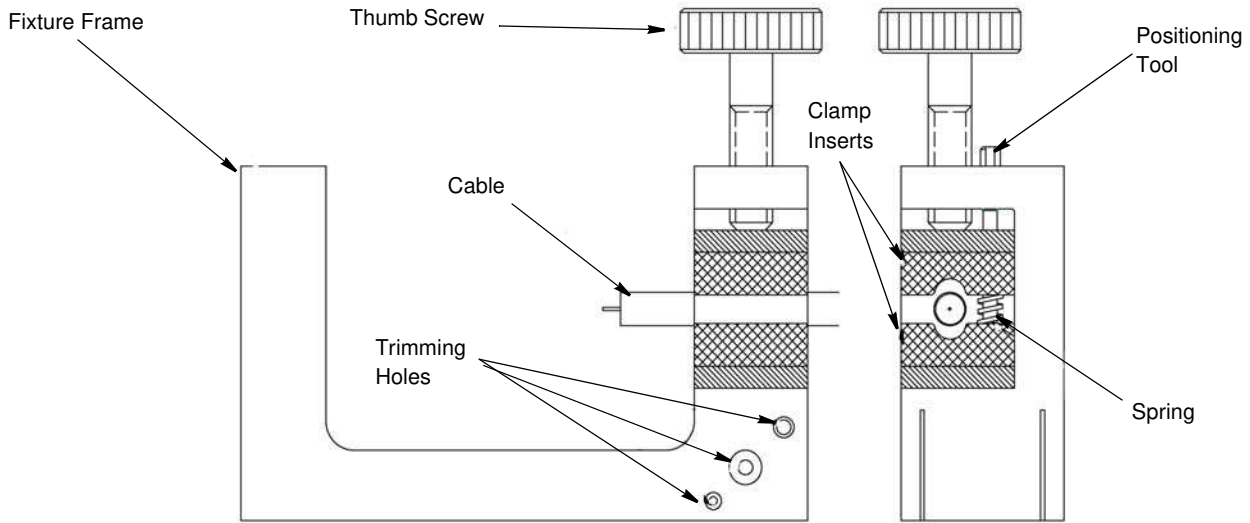

Figure 3

2. Place loose connector assembly in fixture base.
3. Nest the center contact in locator tool.
4. Tighten the thumbscrew to secure the cable.
5. Tighten the locator tool to seat the cable firmly.
6. Slide connector housing over locator tool.
7. Maintain position of housing firmly against locator tool.

8. Solder according to the connector specific instructions.



*To avoid personal injury, be sure to follow all local safety practices when using solder and solder equipment.*

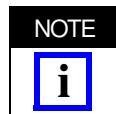

*Fixture should be clamped vertically in vise to keep housing seated against locator tool.*

**7. USING DIELECTRIC TOOLS**

Solder Assembly Kit 10554668-1 contains one dielectric tool. The dielectric (insertion) tool is used to insert the dielectric bushing into the connector housing.

Use the following instruction to press the dielectric bushing into the connector subassembly.

1. Thread the insertion tool into connector subassembly.
2. Insert the dielectric into insertion tool housing.
3. Place insertion tool plunger into position.
4. Press the plunger until the flange bottoms on the tool housing.

**8. REVISION SUMMARY**

Since the previous release of this instruction sheet, the new company logo was applied.

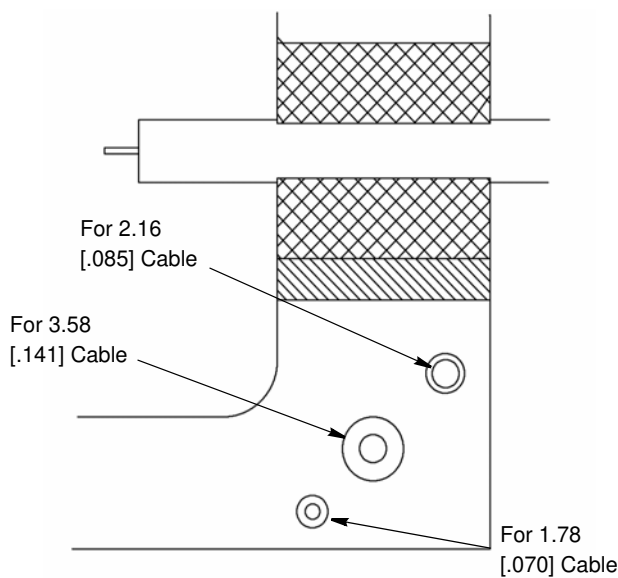

Figure 4