

MM28080H series*

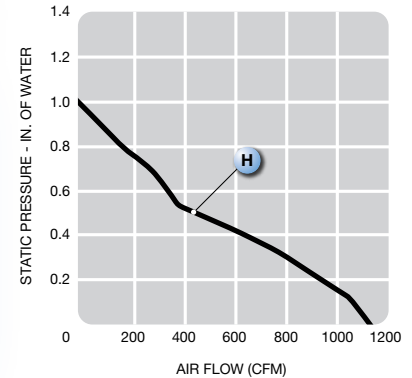
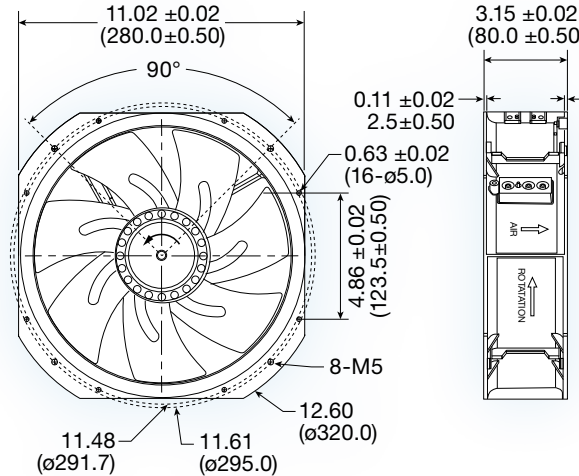

(280 dia. x 80 mm)
11.02 dia. x 3.15 inches

Construction:	magnesium alloy impeller & frame
Bearing option:	ball bearing
Connection:	terminal
Frame:	flanged
Protection:	thermal
Options:	tachometer output or locked rotor alarm signal

Model No.	Rated Voltage V	Current mA		Speed RPM	Air Volume		Max. Static Pressure (H ₂ O)		Sound Noise dbA	Weight kg
		24	48		M ³ /Min.	CFM	MM	INCH		
MM28080H	24/48	5200	2600	3,000	32	1130	25.40	1.0	65	1.60

*Not to be used for new designs