



GN2405 & GN2406 Quad 10Gb/s CDR with Transmit De-Emphasis

FEATURES:

- Automatic locking from 9.95Gb/s to 11.3Gb/s
- Automatic rate detect for quarter rate (2.5Gb/s) and half rate (5Gb/s) modes
- Re-timer bypass up to 11.3Gb/s
- Low output jitter
- High input jitter tolerance, better than 0.7 UI
- No reference clock required
- Programmable output, with 400mV to 800mV differential output voltage range
- Independent channel operation
- De-emphasis to compensate up to 28dB of loss
- I²C control interface
- Automatically loads configuration data from E²PROM
- Loss of signal detect with adjustable threshold
- Low power dissipation
- Single 3.3V supply
- 7x7mm, 48-pin QFN package
- GN2405 and GN2406 are fully pin compatible

APPLICATIONS

- Optical modules and active copper cable assemblies for:
 - Infiniband® SDR/DDR/QDR
 - 40Gb/s and 100Gb/s Ethernet
- Re-timer on line card for:
 - QSFP modules
 - Parallel optical modules
 - SFP+ modules
- 10Gb/s serial backplane retimer

GENERAL DESCRIPTION

The GN2405 and GN2406 are fully pin compatible quad repeater/re-timer devices designed to enhance the reach and robustness of high speed serial links by compensating for transmission losses and re-setting the crosstalk and jitter budget. The GN2405 and GN2406 have different input stages, as shown in the figures below.

The GN2405 and GN2406 feature Gennum's proven reference-free CDR architecture which simplifies system design and reduces overall cost. Each channel supports independent locking to data rates from 9.95 - 11.3Gb/s. To enable backward compatibility with legacy data rates, half rate (5Gb/s) and quarter rate (2.5Gb/s) operation is also supported. Other rates can be supported using the re-timer bypass feature.

The GN2405 and GN2406 can be used in multiple applications. The GN2406's high sensitivity limiting amplifiers removes the need for standalone limiting amplifiers in optical module applications. The GN2405 can be used as a transmit CDR in module applications as its input equalizer can compensate for trace and connector losses. A combination of the output de-emphasis and limiting amplifier can compensate for up to 28dB of loss. Combining these features with the low output jitter of the devices will result in extremely robust high-speed backplane links.

Please see reverse side for a description of some of the applications enabled by Gennum's combination of flexible devices.

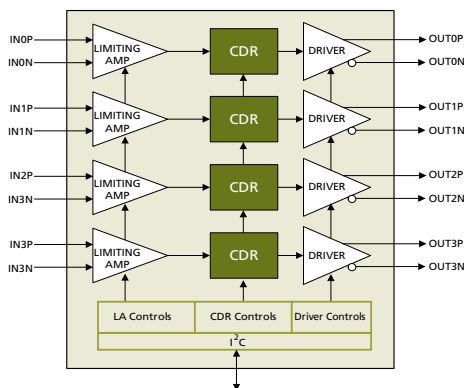

GN2406: Quad 10Gb/s CDR with limiting amplifier

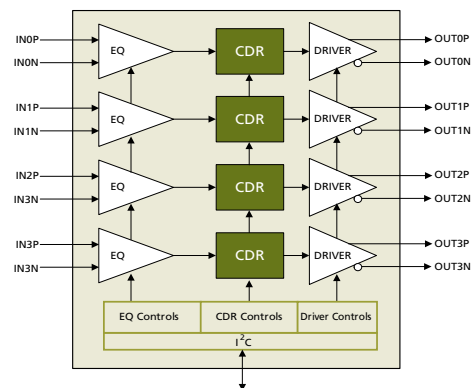

GN2405: Quad 10Gb/s CDR with input equalizer

COPPER CABLE APPLICATIONS

The GN2405 and GN2406 are ideally suited as signal conditioners for active copper cable assemblies supporting Infiniband QDR and 40GbE rates. The de-emphasis will compensate for the loss in the cable and the CDR will reset the jitter and crosstalk budget.

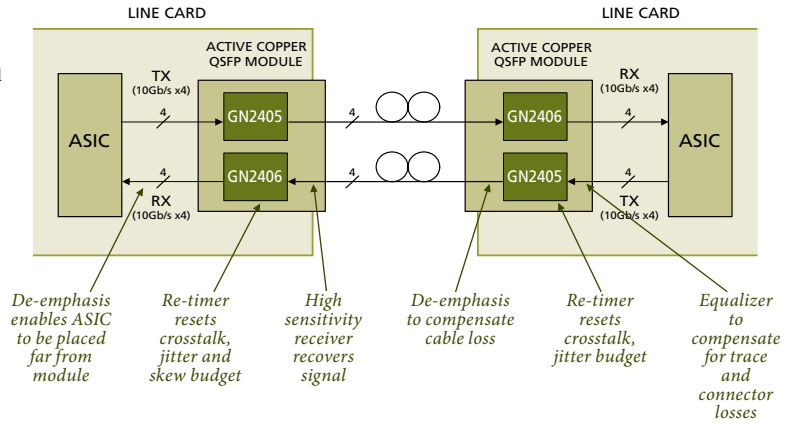

OPTICAL MODULE APPLICATIONS

The GN2406's quad limiting amplifier and CDR combination is optimal as a receive CDR in optical modules. The GN2405's input equalizer will compensate for connector and trace loss and can be used as the transmit CDR.

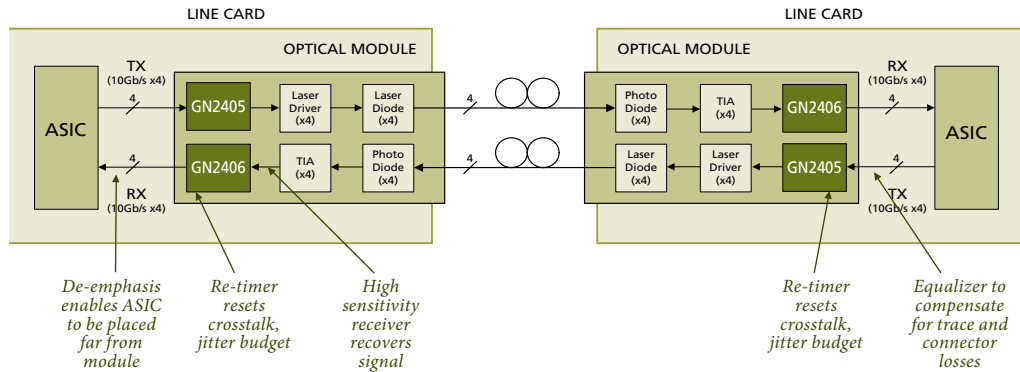

BACKPLANE APPLICATIONS

The GN2405 and GN2406 can be used as backplane extenders in Infiniband QDR, 10GbE or any system running 10G serial over the backplane. The retiming capability and high input jitter tolerance of the devices improve crosstalk performance, which is a significant issue in dense, high speed backplanes.

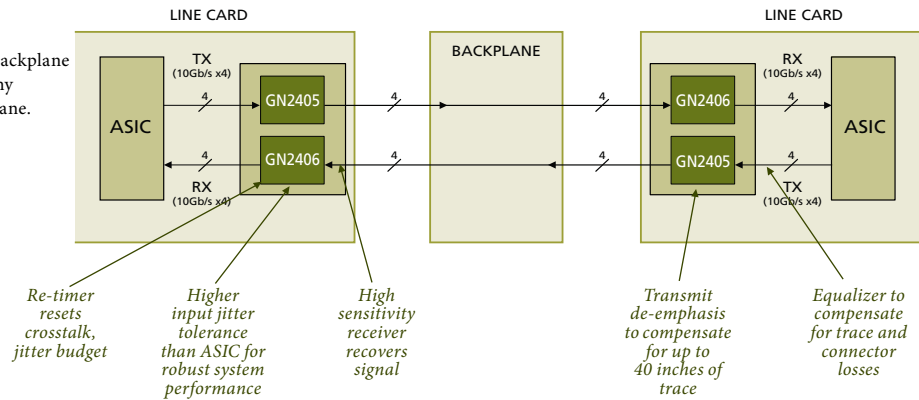

LEARN MORE:

URL: www.gennum.com/cdr
 EMAIL: INFO@GENNUM.COM
 PHONE: (905) 632-2996