

REVISONS		DATE	DMN	APVD
P	LTR	DESCRIPTION		
S		REV PER ECO 13-009679	6-13-13	CT DM

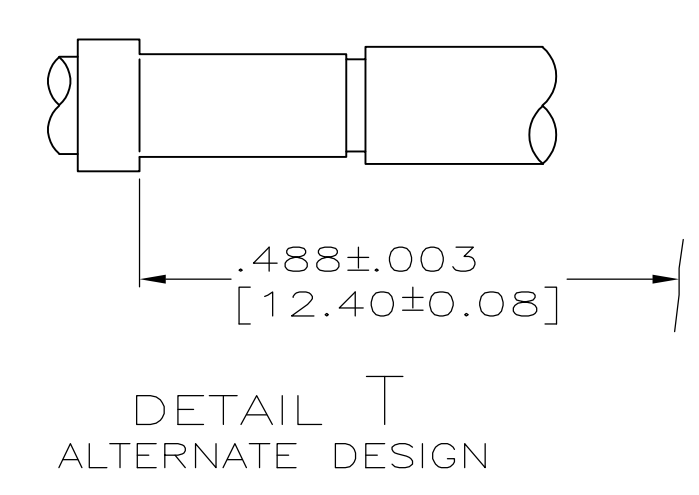
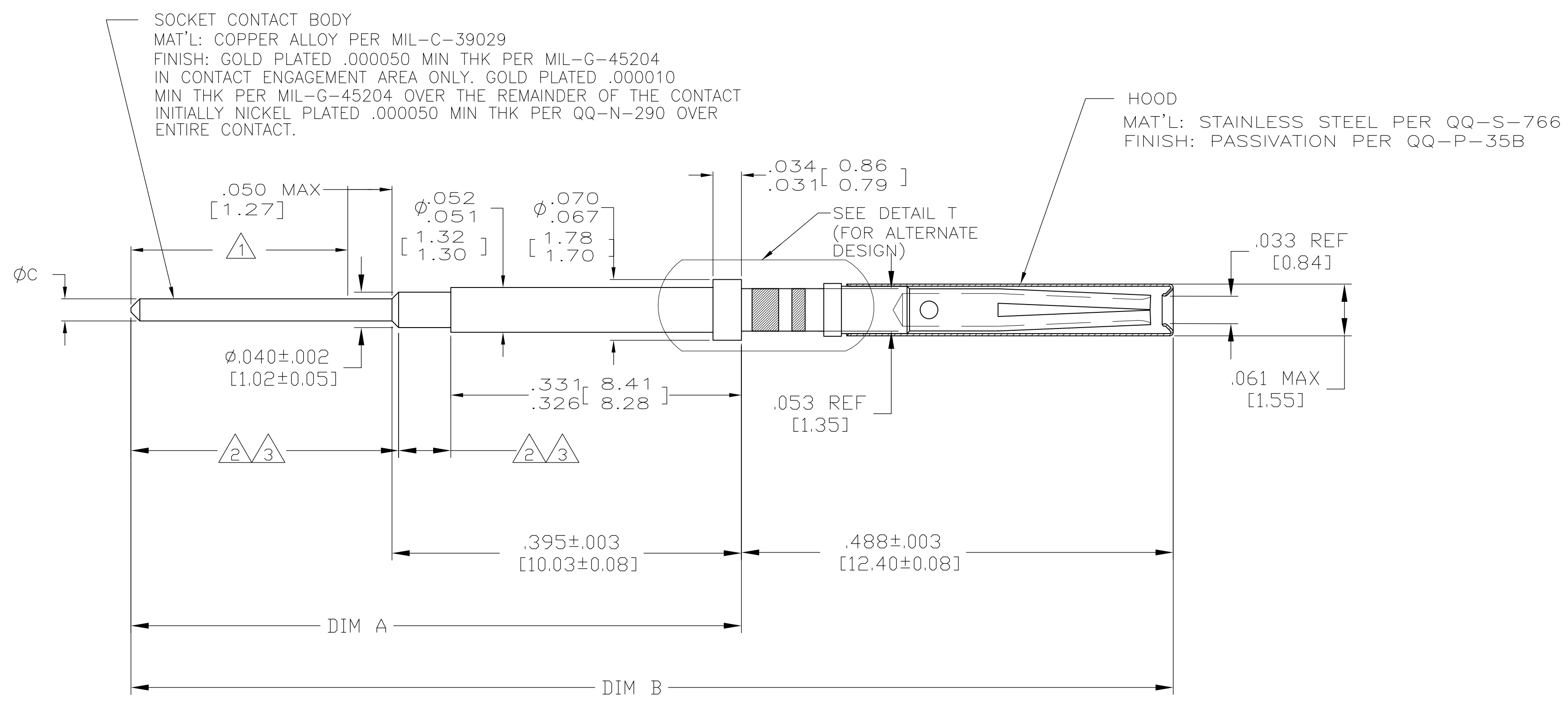

- 1 THIS AREA SOLDER COATED WITH SN60 OR SN63 SOLDER TO WITHIN .050 [1.27] OF CHAMFER, .000060 [0.0015] MIN THICKNESS. (1-211431-3 & 1-211431-5 & 1-211431-6 ONLY) DIMENSIONS SHOWN APPLY BEFORE SOLDER COATING.
- 2 THIS AREA SOLDER COATED WITH SN60 OR SN63 SOLDER .000080 [0.0020] MIN THK. SOLDER PERMISSIBLE ON LARGE DIAMETER AS SHOWN. (1-211431-4 ONLY) DIMENSIONS SHOWN APPLY BEFORE SOLDER COATING.
- 3 THIS AREA SOLDER COATED WITH RoHS COMPLIANT SOLDER .000080 [0.0020] MIN THK. SOLDER PERMISSIBLE ON LARGE DIAMETER AS SHOWN. (1-211431-9 ONLY) DIMENSIONS SHOWN APPLY BEFORE SOLDER COATING.

2	.292 [7.42]	.024-.026 [0.61-0.66]	1.216 [30.89]	.718 [18.24]	2-211431-1
	.292 [7.42]	.024-.026 [0.61-0.66]	1.216 [30.89]	.718 [18.24]	2-211431-0
3	.375 [9.53]	.024-.026 [0.61-0.66]	1.299 [32.99]	.801 [20.35]	1-211431-9
	.330 [8.38]	.024-.026 [0.61-0.66]	1.244 [31.59]	.756 [19.20]	1-211431-8
1	.500 [12.70]	.024-.026 [0.61-0.66]	1.424 [36.17]	.926 [23.52]	1-211431-6
1	.250 [6.35]	.024-.026 [0.61-0.66]	1.174 [29.82]	.676 [17.17]	1-211431-5
2	.375 [9.53]	.024-.026 [0.61-0.66]	1.299 [32.99]	.801 [20.35]	1-211431-4
1	.150 [3.81]	.024-.030 [0.61-0.76]	1.074 [27.28]	.576 [14.63]	1-211431-3
-	.155 [3.94]	.018-.021 [0.46-0.53]	1.064 [27.03]	.576 [14.63]	1-211431-0
-	.500 [12.70]	.024-.026 [0.61-0.66]	1.424 [36.17]	.926 [23.52]	211431-8
-	.375 [9.53]	.024-.026 [0.61-0.66]	1.299 [32.99]	.801 [20.35]	211431-6
-	.250 [6.35]	.024-.026 [0.61-0.66]	1.174 [29.82]	.676 [17.17]	211431-4
-	.150 [3.81]	.024-.026 [0.61-0.66]	1.074 [27.28]	.576 [14.63]	211431-2
REMARKS	MIN EXTENSION BEYOND INSERT	DIM C	DIM B	DIM A	PART NUMBER

THIS DRAWING IS A CONTROLLED DOCUMENT.

DIM P YEAGER 3-28-91
 CHK A SHARPE 3-30-91
 APVD A SHARPE 3-30-91

TE Connectivity

POSTED SOCKET CONTACT ASSY,
 NIC 600, ROUND, SIZE 22,
 FRONT RELEASE

SIZE A1 CASE CODE 00779 DRAWING NO. 211431
 WEIGHT --

CUSTOMER DRAWING SCALE 10:1 SHEET 1 OF 1 REV S