



Model 485DRJ

Multidrop Your RS-485 Network Without Splicing Your Cables

Includes Send Data Control and Two RJ Connectors CE

The 485DRJ is a port-powered, full-duplex or half-duplex RS-232 to RS-485 converter with send data control. The send data control enables the driver without software intervention. The unit converts TD and RD RS-232 lines to balanced RS-485 signals and supports two or four wire RS-485 communications. The converter is powered from the RS-232 handshake lines, RTS, CTS and DTR, DSR, CD. Only one of the handshake lines must be present and in any state to power the converter. No handshake change is necessary so no software is required to control the lines. The RS-485 driver is enabled with each bit of data when in send data control mode. The RS-485 receiver is disabled when the driver is enabled and is enabled when the driver is disabled. This prevents data from being echoed back into the RS-232 device. The RS-232 side has a DB-9 female connector. The RS-485 side has two six-position RJ11 connectors for easy multi-drop connections.

Switches

Switches one and two are used to set up two or four wire mode. In the ON position the converter is in two-wire mode. In the OFF position the 485DRJ is in four-wire mode. Switch three enables the transmitter. In the ON position, the transmitter is enabled when data is sent. In the OFF position the transmitter is always enabled. Switch four controls the receiver. In the ON position the receiver is enabled when data is not being sent. In the OFF position the receiver is always enabled. To set the converter up as RS-422, turn OFF all switches.

Connections

Regardless of the system, the 485DRJ must be connected with the proper polarity. With no data being sent and the driver enabled, the RS-232 line should be negative and the TD(A) should be negative with respect to TD(B).

Proper operation of any RS-485 system requires the presence of a signal return path between the signal grounds of the equipment at each end of an interconnection. This circuit reference may be established by a third conductor connecting the common leads of devices, or it may be provided by connections in each piece of equipment to an earth reference. When the circuit reference is provided by a third conductor, the connection between the signal grounds and the third conductor should contain some resistance (e.g. 100 ohms) to limit circulating currents when other ground connections are provided for safety.

Specifications

Communication: Two or four-wire
 Data Rate: 115.2K Baud max.
 Power: Port-powered from handshake lines
 Dimensions: 7.6 x 5.6 x 2.2 cm (3.0" x 2.2" x 0.9")
 Temperature Range: 0°C to 70°C

Signal	RJ11 Pin #
TDA(-)	2
TDB(+)	1
RDA (-)	5
RDB (+)	6
Signal Ground	4,3

Switch	ON	OFF
SW:1	Two-wire	Four-wire
SW:2	Two-wire	Four-wire
SW:3	SD control	TD enable
SW:4	SD control	RD enable

Modular Connector Pin Assignment



Jack End RJ-11

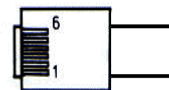

Plug End RJ-11 6 Conductor

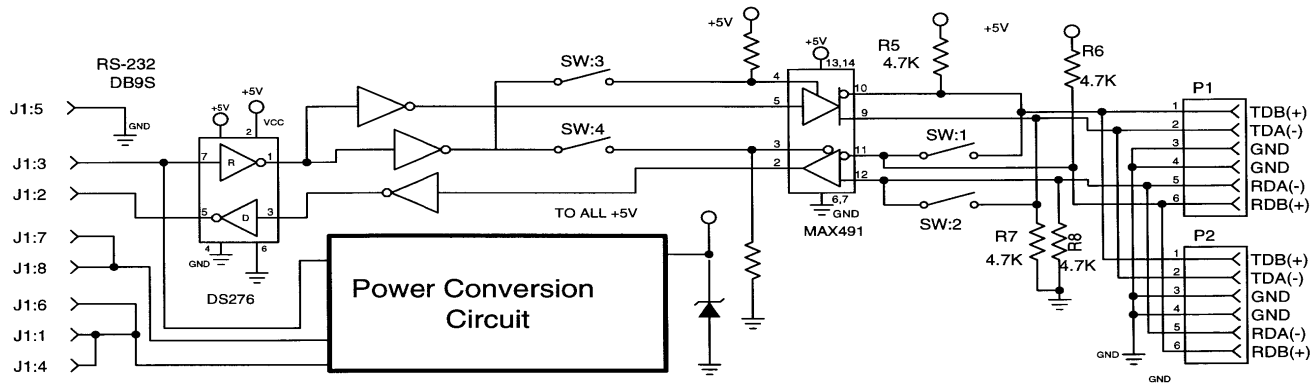

DECLARATION OF CONFORMITY

Manufacturer's Name: B&B Electronics Manufacturing Company
 Manufacturer's Address: P.O. Box 1040
 707 Dayton Road
 Ottawa, IL 61350 USA
 Model Numbers: 485DRJ
 Description: 9-Pin Port-Powered RS-485 Converter
 Type: Light industrial ITE equipment
 Application of Council Directive: 89/336/EEC
 Standards: EN 55022
 EN 61000-6-1
 EN 61000 (-4-2, -4-3, -4-4, -4-5, -4-6, -4-8, -4-11)

Robert M. Paratore, Director of Engineering

