

## Application:

Intel LGA775 Wolfdale / Yorkfield (45nm) CPU  
E8000/E7000/E6000/E5000/Q9000S/Q8000S  
sequence

## Thermal & Mechanical Spec.:

Thermal performance for 65W CPU  
HSK Assembly Weight: 205 g (ref.)  
Clipping Force: 20 Kgf (ref.)

## Picture:



## Component Specification:

### 1. Heat Sink

Type: Extruded HSK

Material: Aluminum A6063 or Equivalent.

Dimension: 90\*90\*19.05 mm



### 2. Thermal interface material

Material: Dow Corning TC-5630 or Equivalent.

### 3. Fan

*(90x90x25 mm with Thermistor & PWM Control)*

Rated Voltage: 12 V

Life Time:

Superflo bearing 50000 hrs

Connector:

a. Lead wire: UL 1430 AWG#26

pin 1: black wire-----(-)

pin 2: yellow wire-----(+)

pin 3: green wire----- (F00)

pin 4: blue wire----- (PWM)

b. Housing: Molex 47054-1000 or equivalent

c. Terminal: Molex 2759T 08-50-0113 or equivalent

\* All readings are typical values at rated voltage.

\* Specifications are subject to change without notice

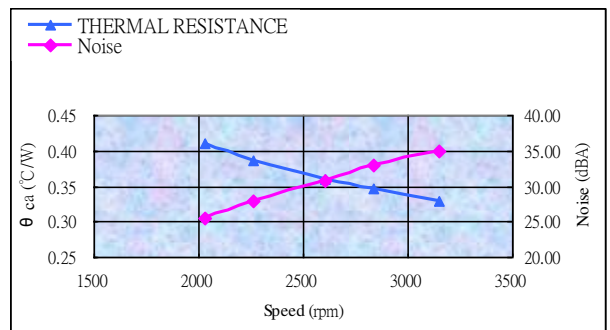
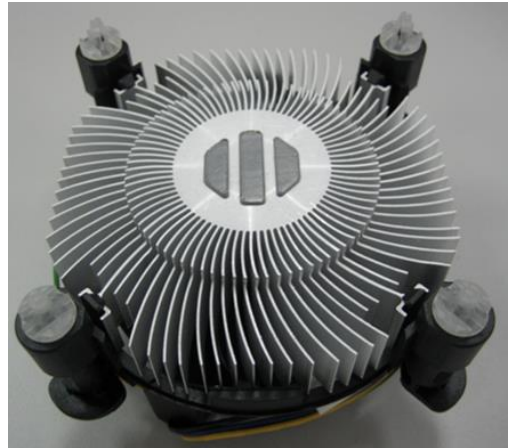



## APPROVAL SHEET

Customer Name .:

Model Name.:

COOLER

Delta Part No.:

FHS-A9025S16

Customer Part No.:

Spec Issue Date .:

12/30/2015

Spec Revision :

04

PLEASE SEND ONE COPY OF THIS SPECIFICATION BACK AFTER YOU  
SIGNED APPROVAL FOR PRODUCTION PRE-ARRANGMENT.

Approved By: \_\_\_\_\_

Date: \_\_\_\_\_

Approval	Check	Designer
Alex-Hsia	Alex-Hsia	Charles Chen



# Delta Electronics Corp.

REV.	Description	Drawn	Checked	Approved	Issue Date
00	ISSUE SPEC	Skyler-Huang06/24'10	Charles.Chen 06/24'10	Alex-Hsia 06/24'10	
01	1. Change the heatsink from 3346208500 to 3346777600 2 .Modify the PD and AS spec	Skyler-Huang05/18'12	Charles.Chen 05/18'12	Alex-Hsia 05/18'12	
02	Modify the Package spec	Skyler-Huang08/09'12	Charles.Chen 08/09'12	Alex-Hsia 08/09'12	
03	Modify the Package spec	Skyler-Huang06/10'13	Charles.Chen 06/10'13	Alex-Hsia 06/10'13	
04	Change TIM from TC-1996 to TC-5630	Charles.Chen 12/30'15	Alex-Hsia 12/30'15	Alex-Hsia 12/30'15	
Description:					
SAMPLE REVISION CODE LIST					
Part No.					REV
DELTA MODEL :  FHS-A9025S16			TOTAL 25 PAGE		04



# Delta Electronics Corp.

## CONTENTS

<b>Item</b>	<b>Element Description</b>	<b>Page</b>	<b>Note</b>
1	Specification	5	
2	Print	6	
3	Packing Plan	12	
4	Fan	15	



# Delta Electronics Corp.

## 1. SPECIFICATION

### Characters

Item	Description
Scope	THIS SPECIFICATION DEFINES THE ELECTRICAL AND MECHANICAL CHARACTERISTICS OF THE FAN HEATSINK
Application	INTEL P4 CPU COOLER
Specification	
a: Thermal Resistance	0.542 (°C/W) (REF.)
b: total weight	232 g (REF.)
c: clip force	20 kgf (REF.)

### BOM

Item	Part Name	Material	Part NO.	Q'TY	Remark
1	FAN	PBT	3622916211	1	
2	HSK	AL A6063	3346208500	1	
3	SCREW	SUS	3105303600	4	
4	SPRING	SWPA	3462009000	4	
5	LABEL	PE	3266799800	1	
6	TIM	DOW TC-5630	4021107300	0.1125g	Rev04



**Delta Electronics Corp.**

## **2. PRINT**

**Assembly Drawing**

**Parts Drawing**

DRAWING:

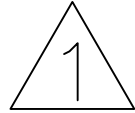
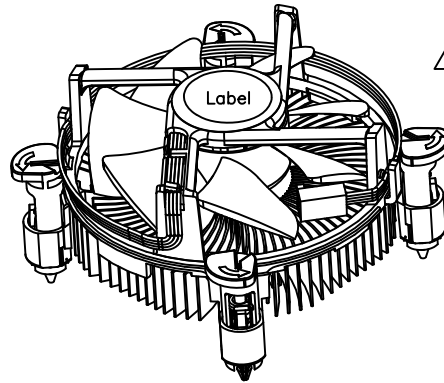
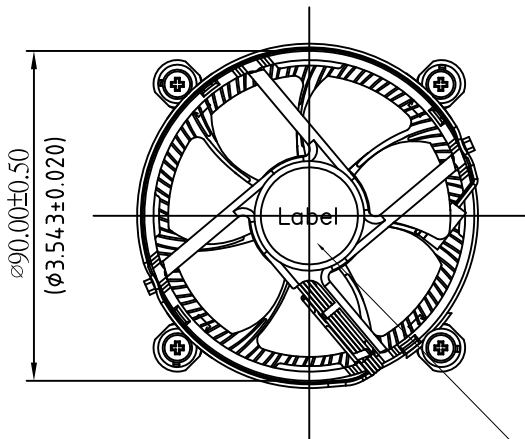

FAN LABEL P/N:3266799800

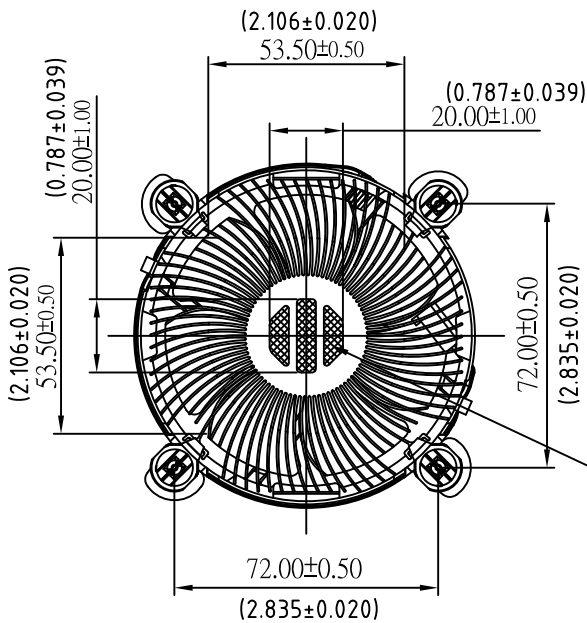
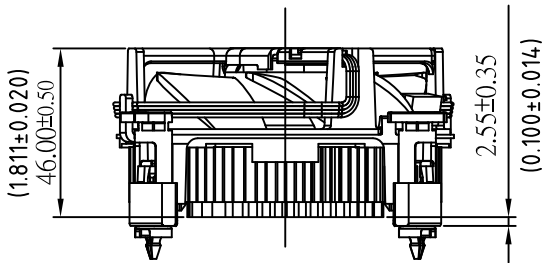

Dow Corning TC-5630 P/N:4021107300

STENCIL THICKNESS=0.20MM(MIN.),0.22MM(MAX.)  
TIM WEIGHT ON HSK MUST BE 112.5mg+/-30mg

UNIT:  $\frac{\text{mm}}{\text{(INCH)}}$



台達電子工業股份有限公司  
DELTA ELECTRONICS, INC.

DELTA MODEL:  
FHS-A9025S16

Drawn:  
Charles Chen 12/30'15

THESE DRAWINGS AND SPECIFICATIONS ARE THE PROPERTY OF DELTA ELECTRONICS, INC. AND SHALL NOT BE REPRODUCED OR USED AS THE BASIS FOR THE MANUFACTURE OR SELL OF APPARATUSES OR DEVICES WITHOUT PERMISSION.

CUSTOMER NAME: -----

CUSTOMER P/N: -----

DIMENSIONAL TOLERANCES		HOLES : $\pm 0.05$		ANGLES : $\pm 0.5^\circ$	
( )	( )	( )	( )	( )	( )
<30	$\pm 0.25$	DECIMALS	UP~100 : $\pm 0.2$	250~300 : $\pm 0.4$	UP~600 : $\pm 1.5$
>30~100	$\pm 0.35$	X : $\pm 0.3$	100~150 : $\pm 0.25$	300~350 : $\pm 0.45$	600~900 : $\pm 2.4$
>100~300	$\pm 0.5$	XX : $\pm 0.2$	150~200 : $\pm 0.3$	350~400 : $\pm 0.5$	900~OVER : $\pm 3.1$
ABOVE 300	$\pm 0.6$	XXX : $\pm 0.1$	200~250 : $\pm 0.35$		



Description: PRODUCTION SPEC.  
(PHYSICAL DIMENSION)

A4  
SIZE

Part No. FHS-A9025S16-PD

REV.

SHEET 1 OF 2 ISSUE DATE:

---

SCALE --- UNIT mm USED ON COOLER



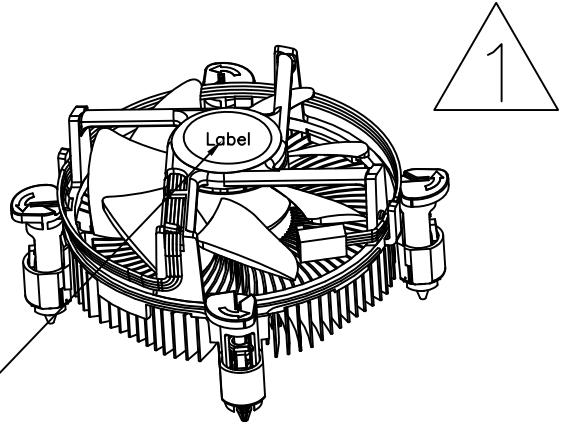

DATECODE POSITION



NOTE:

1. DATECODE ON FAN LABEL
2. PLEASE REFER TO CP10S-00345 WHILE PRINTING DATECODE

 <b>台達電子工業股份有限公司</b> <b>DELTA ELECTRONICS, INC.</b>	<b>DELTA MODEL:</b> <b>FHS-A9025S16</b>		<b>Drawn:</b> Charles Chen 12/30'15		
	<b>THESE DRAWINGS AND SPECIFICATIONS ARE THE PROPERTY OF DELTA ELECTRONICS, INC. AND SHALL NOT BE REPRODUCED OR USED AS THE BASIS FOR THE MANUFACTURE OR SELL OF APPARATUSES OR DEVICES WITHOUT PERMISSION.</b>				
<b>DIMENSIONAL TOLERANCES</b> ( ) ( ) ( ) ( ) <30 :±0.25    X :±0.3    UP~100 :±0.2    250~300 :±0.4    UP~600 :±1.5 >30~100 :±0.35    X :±0.3    100~150 :±0.25    300~350 :±0.45    600~900 :±2.4 >100~300 :±0.5    X.X :±0.2    150~200 :±0.3    350~400 :±0.5    900~OVER :±3.1 ABOVE 300 :±0.6    X.XX :±0.1    200~250 :±0.35		<b>HOLES : ±0.05    ANGLES : ±0.5°</b> 		<b>Description:</b> <b>PRODUCTION SPEC.</b> (PHYSICAL DIMENSION)	
<b>SCALE</b> --- <b>UNIT</b> mm <b>USED ON</b> COOLER		<b>Part No.</b> <b>FHS-A9025S16-PD</b>		<b>REV.</b> ---	
		<b>SIZE</b> A4		<b>SHEET 2 OF 2</b> <b>ISSUE DATE:</b>	



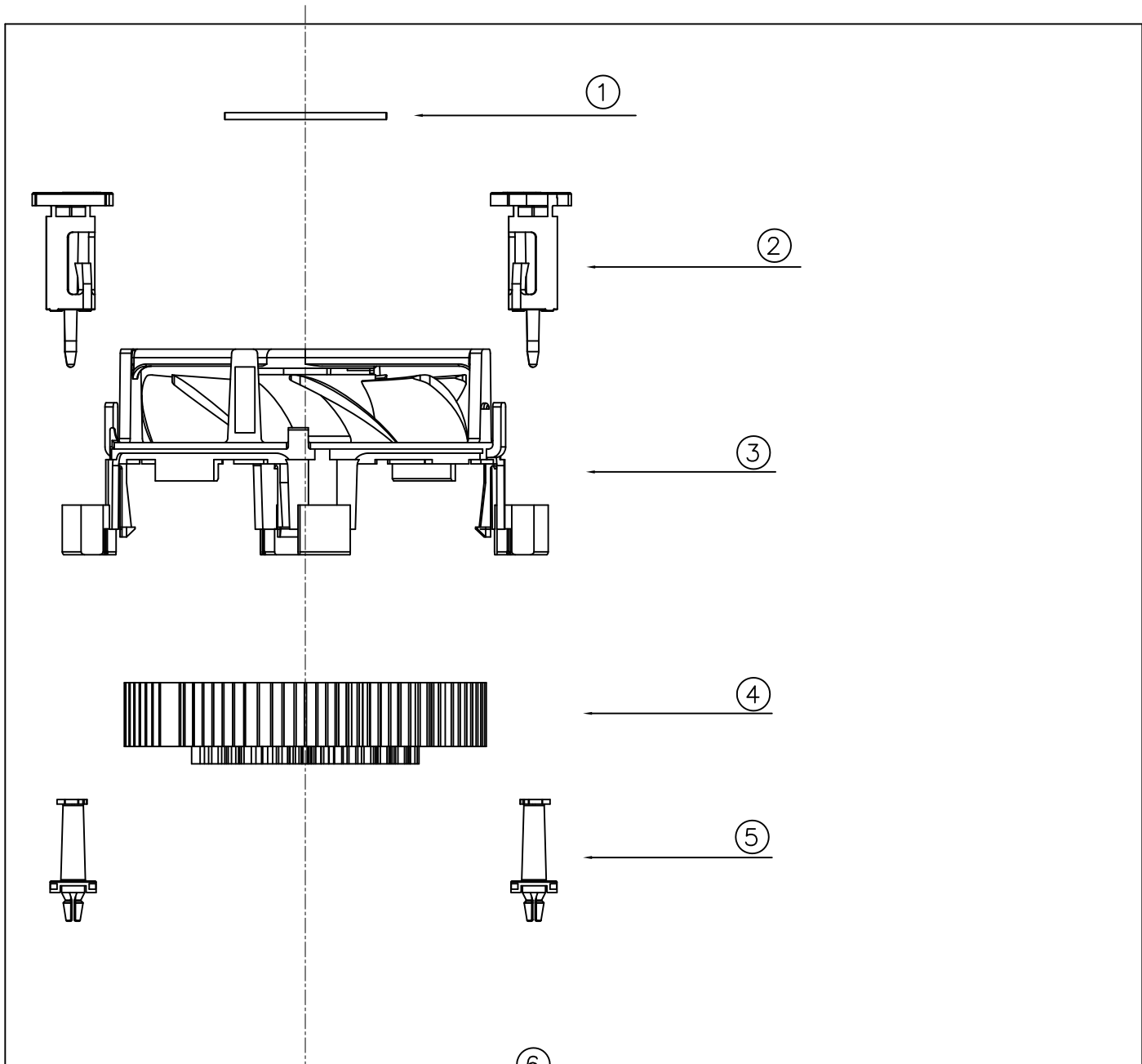

6	1	TIM	4021107300
5	4	FASTENER BASE	3470415500
4	1	HEATSINK	3346777600
3	1	FAN	3622916211
2	4	FASTENER CAP	3470415400
1	1	FAN LABEL	3266799800
ITEM	QTY	DESCRIPTION	PART NUMBER

<b>台達電子工業股份有限公司</b> <b>DELTA ELECTRONICS, INC.</b>	<b>DELTA MODEL:</b> <b>FHS-A9025S16</b>	<b>Drawn:</b> Charles Chen 12/30'15
	<b>CUSTOMER NAME:</b> -----	
<b>CUSTOMER P/N:</b> -----		<b>Description:</b> PRODUCTION SPEC. (ASSEMBLY ORDER)
<b>DIMENSIONAL TOLERANCES</b> ( ) ( ) ( ) ( ) <30 :±0.25    X :±0.3    UP~100 :±0.2    250~300 :±0.4    UP~600 :±1.5 >30~100 :±0.35    X.X :±0.2    100~150 :±0.25    300~350 :±0.45    600~900 :±2.4 >100~300 :±0.5    X.XX :±0.1    150~200 :±0.3    350~400 :±0.5    900~OVER :±3.1 ABOVE 300 :±0.6    X.XX :±0.1    200~250 :±0.35	<b>Holes : ±0.05</b> <b>Angles : ±0.5°</b>	
<b>SCALE</b> --- <b>UNIT</b> mm <b>USED ON</b> COOLER	<b>A4</b> <b>SIZE</b>	<b>Part No.</b> FHS-A9025S16P-AS <b>REV.</b> --- <b>SHEET 1 OF 1</b> <b>ISSUE DATE:</b>

1

2

3

4

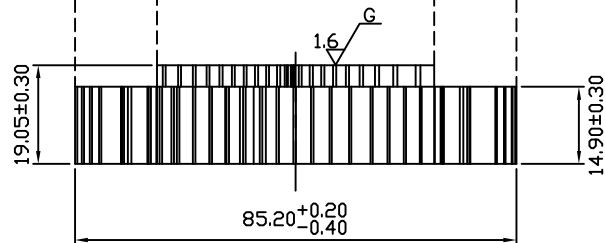
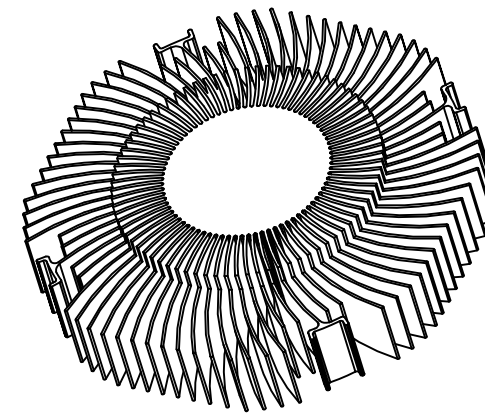
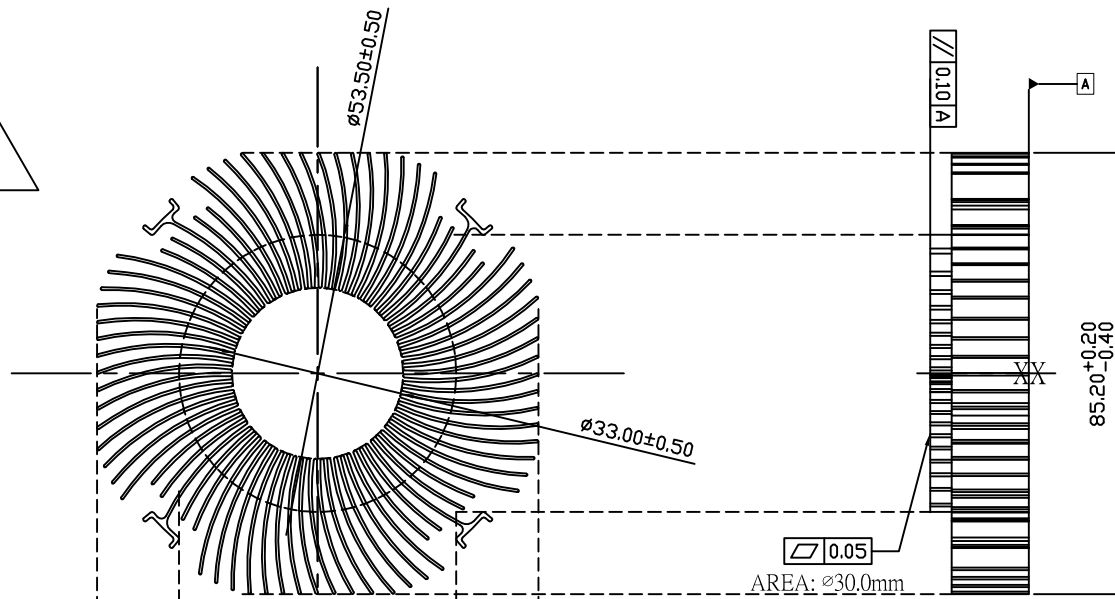
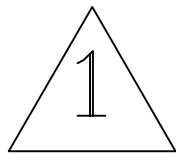

NOTES:

\*1.MATERIAL: A6063 T5, FINISH:NONE

<b>台達電子工業股份有限公司</b> DELTA ELECTRONICS, INC.		Drawn: Skyler	
THESE DRAWINGS AND SPECIFICATIONS ARE THE PROPERTY OF DELTA ELECTRONICS, INC. AND SHALL NOT BE REPRODUCED OR USED AS THE BASIS FOR THE MANUFACTURE OR SELL OF APPARATUS OR DEVICES WITHOUT PERMISSION.		DESCRIPTION: <b>HEATSINK</b>	
DIMENSIONAL TOLERANCES ( ) ( ) ( ) ( ) <30 :±0.25    DECIMALS    UP~100 :±0.2    250~300 :±0.4    UP~600 :±1.5 >30~100 :±0.35    X :±0.5    100~150 :±0.25    300~350 :±0.45    600~900 :±2.4 >100~300 :±0.5    XX :±0.3    150~200 :±0.3    350~400 :±0.5    900~OVER :±3.1 ABOVE 300 :±0.6    XXX :±0.25    200~250 :±0.35		PART NO.: <b>3346777600</b>	
SCALE	1/1	UNIT	mm
USED ON	COOLER	SHEET 2 OF 2	

1

2

3

4

A

A

B



B

C

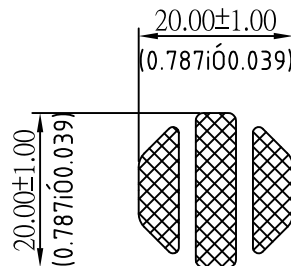
C



- NOTES:
1. THICKNESS: 0.20mm
  2. VENDOR P/N: DOW CORNING TC-5630
  3. COLOR: GRAY.
  4. THERMAL CONDUCTIVITY: 4.5 W/m-°C
  5. THERMAL CONTACT RESISTANCE: 0.06 °C-cm<sup>2</sup>/W @40psi
  6. GROSS WEIGHT: 112.5±30 mg
  7. VENDOR : DOW CORNING
  8. MUST MEET DELTA'S SPEC : 10000-0162

 <b>台達電子工業股份有限公司</b> DELTA ELECTRONICS, INC.					Drawn: Charles Chen 12/30'15	
THESE DRAWINGS AND SPECIFICATIONS ARE THE PROPERTY OF DELTA ELECTRONICS, INC. AND SHALL NOT BE REPRODUCED OR USED AS THE BASIS FOR THE MANUFACTURE OR SELL OF APPARATUSES OR DEVICES WITHOUT PERMISSION.					 DESCRIPTION: THERMAL INTERFACE	
DIMENSIONAL TOLERANCES ( ) ( ) ( ) ( ) (<math>\sqrt{}</math>) ( ) ( ) ( ) <math><30</math> :±0.25    DECIMALS    UP~100 :±0.2    250~300 :±0.4    UP~600 :±1.5 >30~100 :±0.35    X :±0.5    100~150 :±0.25    300~350 :±0.45    600~900 :±2.4 >100~300 :±0.5    XX :±0.2    150~200 :±0.3    350~400 :±0.5    900~OVER :±3.1 ABOVE 300 :±0.6    XXX :±0.1    200~250 :±0.35			HOLES : ±0.05    ANGLES : ±0.6°		PART NO.: 4021107300	REV. --
SCALE	1/1	UNIT	mm	USED ON	COOLER	SHEET 1 OF 1

1

2

3

4



**Delta Electronics Corp.**

### **3. PACKING PLAN**

#### **Packing Specification**

CARTON ILLUSTRATE	SIZE	524(L)*225(w)*475(H)(mm)	PACKING QUANTITY	6LAYERS/CARTON
	MATERIAL	3 LAYERS"AB" FLUTE	CARTON WEIGHT	0.62 kg (REF.)

CARTON OUTSIDE ILLUSTRATE

FRONT

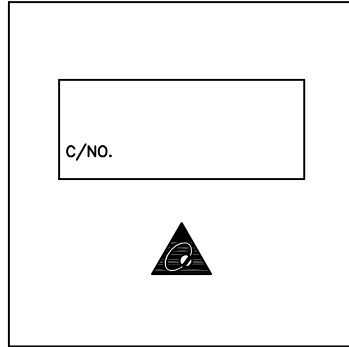

BACK

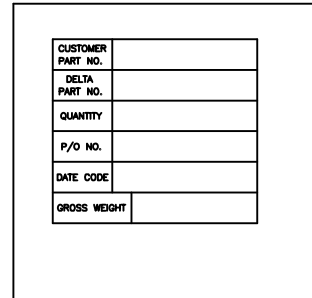

(ONE LABEL PER CARTON)

PET TRAY PACKING ILLUSTRATE	SIZE	94(L)*94(w)*30(H)(mm)	PACKING QUANTITY	1PCS/PET TRAY
	MATERIAL	PET TRAY		
	MATERIAL WEIGHT	6g (REF.)		

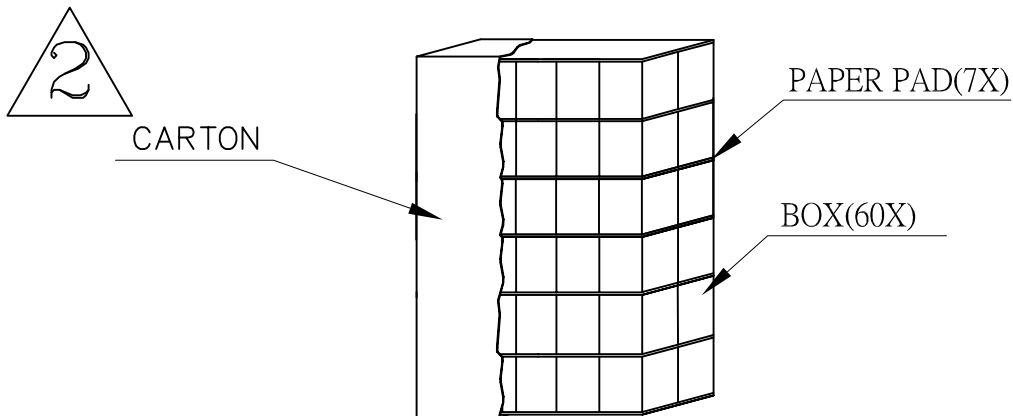

台達電子工業股份有限公司  
DELTA ELECTRONICS, INC.

DELTA MODEL:  
FHS-A9025S16

Drawn:  
Skyler Huang

THESE DRAWINGS AND SPECIFICATIONS ARE THE PROPERTY OF DELTA ELECTRONICS, INC. AND SHALL NOT BE REPRODUCED OR USED AS THE BASIS FOR THE MANUFACTURE OR SELL OF APPARATUS OR DEVICES WITHOUT PERMISSION.

CUSTOMER NAME: -----  
CUSTOMER P/N: -----

DIMENSIONAL TOLERANCES		HOLES : ±0.05		ANGLES : ±0.5°	
( )	( )	( )	( )	( )	( )
<30	±0.25	DECIMALS	UP~100 ±0.2	250~300 ±0.4	UP~800 ±1.5
>30~100	±0.35	X	±0.3	100~150 ±0.25	300~350 ±0.45
>100~300	±0.5	XX	±0.2	150~200 ±0.3	350~400 ±0.5
ABOVE 300	±0.6	XXX	±0.1	200~250 ±0.35	900~OVER ±3.1

Description: PRODUCTION SPEC.  
(PACKING ASSMEBLY)

A4  
SIZE

Part No.  
FHS-A9025S16-PA

REV.  
---

SCALE --- UNIT mm USED ON COOLER

SHEET 1 OF 2 ISSUE DATE:

PART NO.	FHS-A9025S16																	
BASIC DATA	QUANTITY/CARTON	60PCS (6 LAYERS/CARTON, 10PCS/LAYER)																
	PRODUCTION NET WEIGHT	12.3kg (REF.)																
	PRODUCTION GROSS WEIGHT	16.1kg (REF.)																
20(ft)CONTAINER ILLUSTRATE	SIZE	5.889(L)*2.352(w)*2.386(H)m		PACKING QUANTITY														
	CONTAINER	STEEL		20PALLET/CONTAINER														
CONTAINER FORM																		
CONTAINER LOADING MATHOD																		
<table border="1"> <tr> <td>PALLET</td> <td>PALLET</td> <td>PALLET</td> <td>PALLET</td> <td>PALLET</td> </tr> <tr> <td>PALLET</td> <td>PALLET</td> <td>PALLET</td> <td>PALLET</td> <td>PALLET</td> </tr> </table> <p style="text-align: center;">TOP VIEW</p>				PALLET	PALLET	PALLET	PALLET	PALLET	PALLET	PALLET	PALLET	PALLET	PALLET	<table border="1"> <tr> <td>PALLET</td> <td>PALLET</td> </tr> <tr> <td>PALLET</td> <td>PALLET</td> </tr> </table> <p style="text-align: center;">FRONT VIEW</p>	PALLET	PALLET	PALLET	PALLET
PALLET	PALLET	PALLET	PALLET	PALLET														
PALLET	PALLET	PALLET	PALLET	PALLET														
PALLET	PALLET																	
PALLET	PALLET																	

PALLET LOADING ILLUSTRATE	SIZE	117(L)*107(w)*13(H)cm	PACKING QUANTITY	20 CARTONS/PALLET
	PALLET	WOOD		

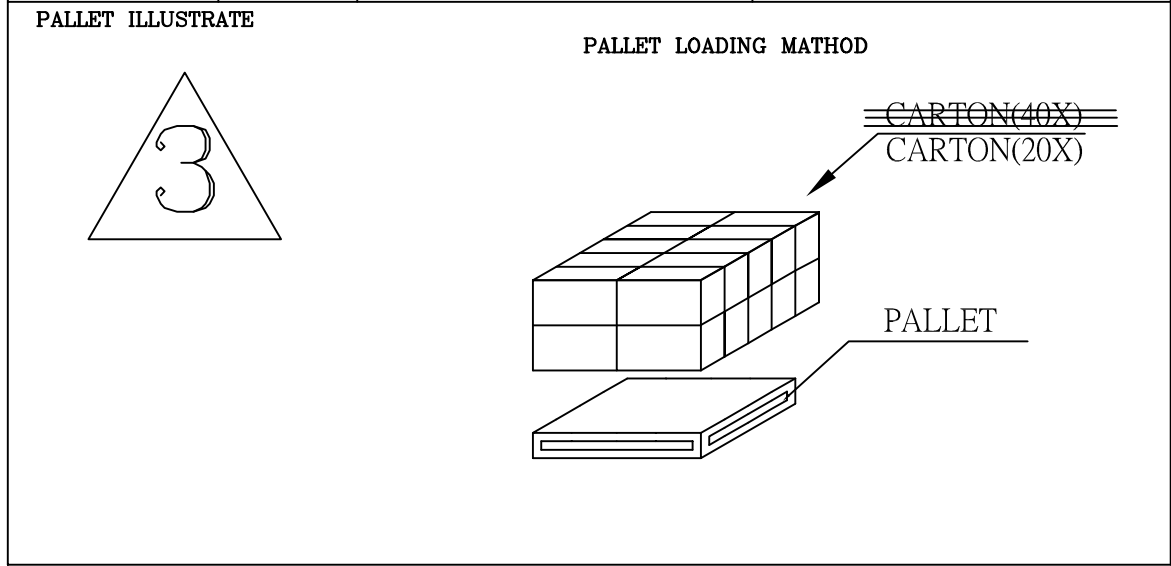

<b>台達電子工業股份有限公司</b> <b>DELTA ELECTRONICS, INC.</b>	DELTA MODEL:	FHS-A9025S16	Drawn:	Skyler Huang
	THESE DRAWINGS AND SPECIFICATIONS ARE THE PROPERTY OF DELTA ELECTRONICS, INC. AND SHALL NOT BE REPRODUCED OR USED AS THE BASIS FOR THE MANUFACTURE OR SELL OF APPARATUSES OR DEVICES WITHOUT PERMISSION.	CUSTOMER NAME:	-----	CUSTOMER P/N:
<b>DIMENSIONAL TOLERANCES</b> ( ) ( ) ( ) HOLES : ±0.05 ANGLES : ±0.5° <30 :±0.25 DECIMALS UP~100 :±0.2 250~300 :±0.4 UP~800 :±1.5 >30~100 :±0.35 X :±0.3 100~150 :±0.25 300~350 :±0.45 800~900 :±2.4 >100~300 :±0.5 XX :±0.2 150~200 :±0.3 350~400 :±0.5 900~OVER :±3.1 ABOVE 300 :±0.6 XXX :±0.1 200~250 :±0.35	Description: PRODUCTION SPEC. (PACKING ASSMEBLY)	Part No. FHS-A9025S16-PA	REV. ---	
SCALE --- UNIT mm USED ON COOLER	A4 SIZE	SHEET 2 OF 2	ISSUE DATE:	



**Delta Electronics Corp.**

## **4. FAN**

### **Fan Specification**



## SPECIFICATION FOR APPROVAL

Customer TMPBU

Description DC FAN

Part No. \_\_\_\_\_ REV. \_\_\_\_\_

Delta Model No. AUC0912D-8H79 REV. 01

Sample Issue No. \_\_\_\_\_

Sample Issue Date OCT.06.2008

PLEASE SEND ONE COPY OF THIS SPECIFICATION  
BACK AFTER YOU SIGNED APPROVAL FOR  
PRODUCTION PRE-ARRANGMENT.

APPROVED BY: \_\_\_\_\_

DATE : \_\_\_\_\_

DELTA ELECTRONICS, INC.  
TAOYUAN PLANT  
252, SHANG YING ROAD, KUEI SAN INDUSTRIAL ZONE  
TAOYUAN SHIEN, TAIWAN, R.O.C.  
TEL:886-(0)3-3591968  
FAX:886-(0)3-3591991



DELTA ELECTRONICS, INC.  
 252, SHANG YING ROAD, KUEI SAN  
 TAOYUAN HSIEN 333, TAIWAN, R. O. C.

TEL : 886-(0)3-3591968  
 FAX : 886-(0)3-3591991

**SPECIFICATION FOR APPROVAL**  
 \*\*\*\*\*

Customer: TMP BU  
 -----  
 Description: DC FAN  
 -----  
 Customer P/N: REV:  
 -----  
 Delta Model NO.: AUC0912D-8H79  
 -----  
 Sample Rev: 01 Issue NO:  
 -----  
 Sample Issue Date: OCT.06.2008 Quantity:  
 -----

1. SCOPE:

THIS SPECIFICATION DEFINES THE ELECTRICAL AND MECHANICAL CHARACTERISTICS OF THE DC BRUSHLESS AXIAL FLOW FAN. THE FAN MOTOR IS WITH SINGLE PHASES AND FOUR POLES.

2. CHARACTERS:

ITEM	DESCRIPTION	
SENSOR TEMPERATURE	30°C	38°C
RATED VOLTAGE	12.0 VDC	
OPERATION VOLTAGE	10.8 - 13.2 VDC	
START UP CURRENT	MAX. 0.60A	MAX. 0.73A
INPUT CURRENT	0.07 (MAX. 0.14) A	0.14 (MAX. 0.46) A
INPUT POWER	0.84 (MAX. 1.68) W	1.68 (MAX. 5.52) W
SPEED (FAN ONLY)	2000±10% R.P.M.	3200±10% R.P.M.
SPEED (FAN ON SINK)	2000±10% R.P.M.	3150±10% R.P.M.
MAX. AIR FLOW (FAN ONLY) (AT ZERO STATIC PRESSURE)	0.537 (MIN. 0.483) M <sup>3</sup> /MIN. 18.96 (MIN. 17.06) CFM	0.914 (MIN. 0.823) M <sup>3</sup> /MIN. 32.29 (MIN. 29.06) CFM
MAX. AIR PRESSURE (FAN ONLY) (AT ZERO AIRFLOW)	1.53 (MIN. 1.24) mmH <sub>2</sub> O 0.060 (MIN. 0.049) inchH <sub>2</sub> O	3.61 (MIN. 2.92 ) mmH <sub>2</sub> O 0.142 (MIN. 0.115) inchH <sub>2</sub> O
ACOUSTICAL NOISE(ON SINK AVG.)	26.0 (MAX. 30.0) dB-A	36.0 (MAX. 40.0) dB-A
INSULATION TYPE	UL: CLASS A	

(continued)

PART NO:

DELTA MODEL: AUC0912D-8H79

INSULATION STRENGTH	10 MEG OHM MIN. AT 500 VDC (BETWEEN FRAME AND (+) TERMINAL)
DIELECTRIC STRENGTH	5 mA MAX. AT 500 VAC 60 Hz ONE MINUTE, (BETWEEN FRAME AND (+) TERMINAL)
EXTERNAL COVER	OPEN TYPE
LIFE EXPECTANCE	50,000 HOURS CONTINUOUS OPERATION AT 40 °C WITH 15 ~ 65 %RH.
ROTATION	CLOCKWISE VIEW FROM NAME PLATE SIDE
OVER CURRENT SHUT DOWN	THE CURRENT WILL SHUT DOWN WHEN LOCKING ROTOR
LEAD WIRE	UL 1430 -F- AWG #26 BLACK WIRE:NEGATIVE(-) YELLOW WIRE:POSITIVE(+) GREEN WIRE:TACHOMETER OUTPUT (F00) BLUE WIRE:SPEED CONTROL (PWM)

- NOTES: 1. ALL READINGS ARE MEASURED AFTER STABLY WARMING UP THROUGH 10 MINUTES.  
2. THE VALUES WRITTEN IN PARENS , ( ), ARE LIMITED SPEC.  
3. ACOUSTICAL NOISE MEASURING CONDITION:

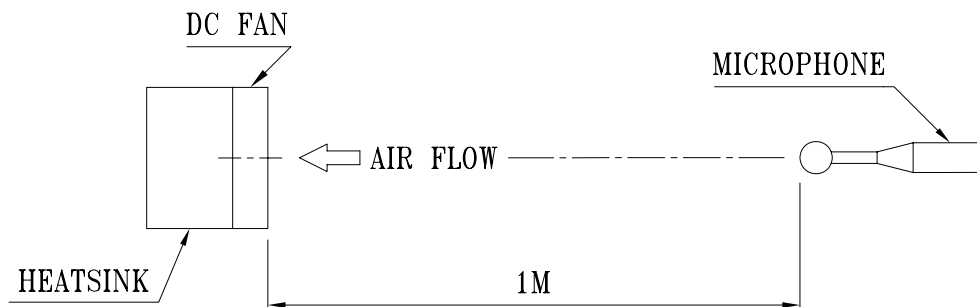

NOISE IS MEASURED AT RATED VOLTAGE IN FREE AIR IN ANECHOIC CHAMBER WITH B & K SOUND LEVEL METER WITH MICROPHONE AT A DISTANCE OF ONE METER FROM THE FAN INTAKE.

-----  
PART NO:  
-----

DELTA MODEL:           AUC0912D-8H79  
-----

3. MECHANICAL:

- 3-1. DIMENSIONS ----- SEE DIMENSIONS DRAWING
- 3-2. FRAME ----- PLASTIC UL: 94V-0
- 3-3. IMPELLER ----- PLASTIC UL: 94V-0
- 3-4. BEARING SYSTEM ----- SUPERFLO BEARING
- 3-5. WEIGHT ----- 82 GRAMS

4. ENVIRONMENTAL:

- 4-1. OPERATING TEMPERATURE ----- -10 TO +60 DEGREE C
- 4-2. STORAGE TEMPERATURE ----- -40 TO +70 DEGREE C
- 4-3. OPERATING HUMIDITY ----- 5 TO 95 % RH
- 4-4. STORAGE HUMIDITY ----- 5 TO 95 % RH

5. PROTECTION:

- 5-1. LOCKED ROTOR PROTECTION  
IMPEDANCE OF MOTOR WINDING PROTECTS MOTOR FROM FIRE IN 96 HOURS OF LOCKED ROTOR CONDITION AT THE RATED VOLTAGE.
- 5-2. POLARITY PROTECTION  
BE CAPABLE OF WITHSTANDING IF REVERSE CONNECTION FOR POSITIVE AND NEGATIVE LEADS.

6. RE OZONE DEPLETING SUBSTANCES:

- 6-1. NO CONTAINING PBBs, PBBOs, CFCs, PBBEs, PBDPEs AND HCFCs.

7. PRODUCTION LOCATION

- 7-1. PRODUCTS WILL BE PRODUCED IN CHINA OR THAILAND OR TAIWAN.

PART NO:

DELTA MODEL: AUC0912D-8H79

8. P & Q CURVE:  
PWM 100% DUTY CYCLE

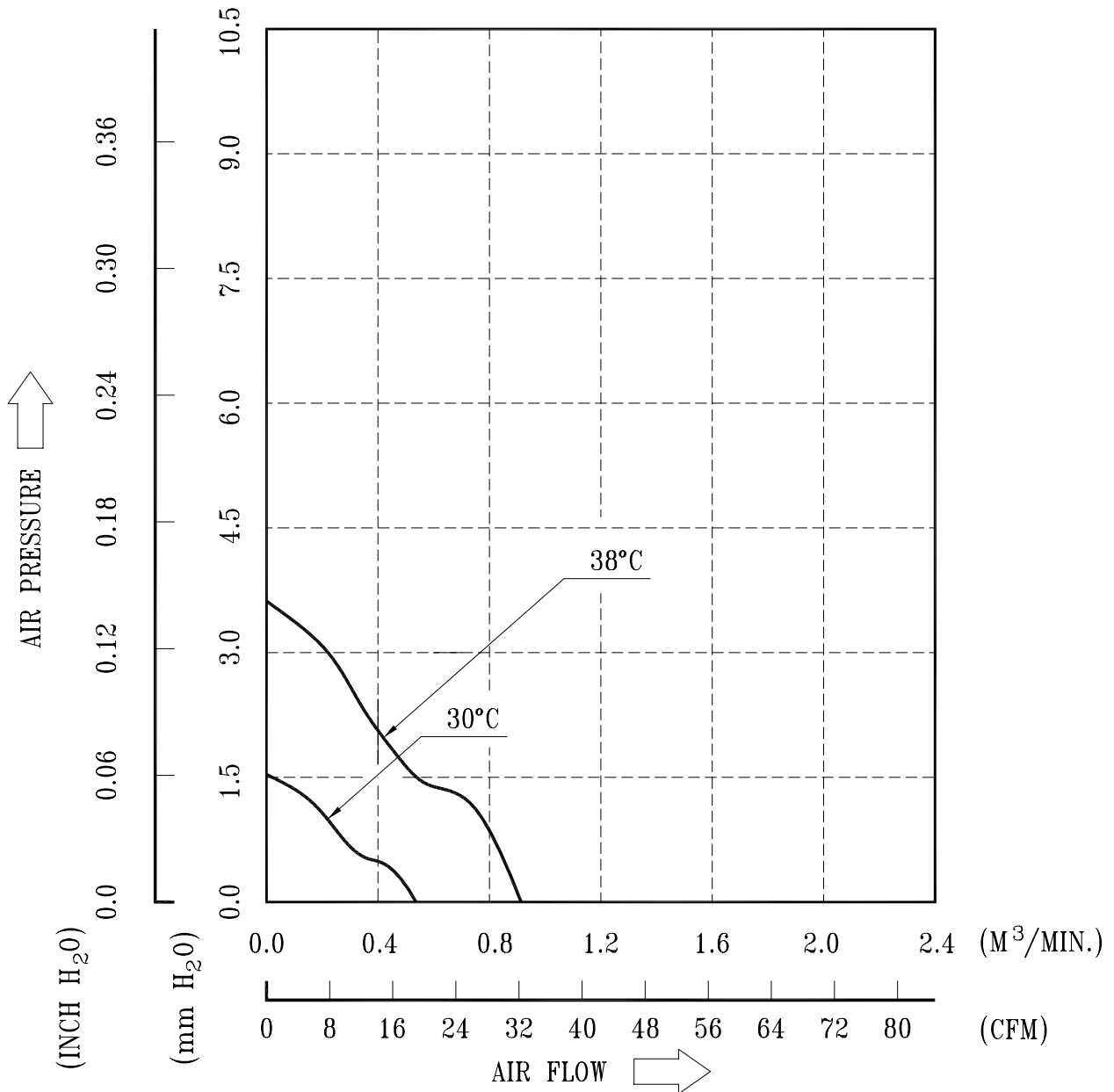

\* TEST CONDITION: INPUT VOLTAGE ----- OPERATION VOLTAGE  
TEMPERATURE ----- ROOM TEMPERATURE  
HUMIDITY ----- 65%RH

-----  
PART NO:  
-----

DELTA MODEL:           AUC0912D-8H79  
-----

9. DIMENSION DRAWING:

LABEL:

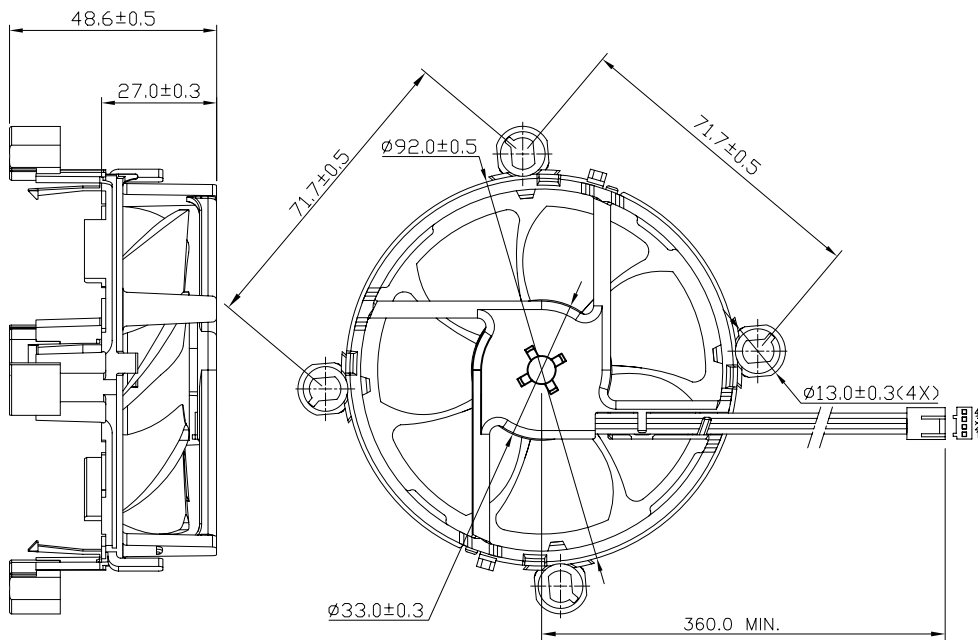

UNIT: MM

- NOTE : 1. LEAD WIRE: UL 1430 -F- AWG #26  
PIN 1 : BLACK WIRE: NEGATIVE(-)  
PIN 2 : YELLOW WIRE: POSITIVE(+)  
PIN 3 : GREEN WIRE: TACHOMETER OUTPUT (F00)  
PIN 4 : BLUE WIRE: SPEED CONTROL (PWM)  
2. HOUSING : MOLEX 47054-1000 OR EQUIVALENT  
3. TERMINAL : MOLEX 2759T 08-50-0113 OR EQUIVALENT  
4. THIS PRODUCT IS RoHS COMPLIANT

PART NO:

DELTA MODEL: AUC0912D-8H79

10. FREQUENCY GENERATOR (FG) SIGNAL:

1. OUTPUT CIRCUIT - OPEN COLLECTOR MODE:

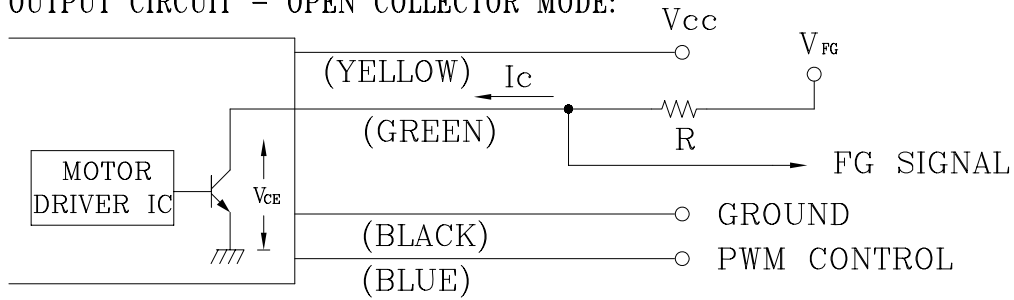

CAUTION: THE FG SIGNAL LEAD WIRE MUST BE KEPT AWAY FROM  
" + " LEAD WIRE & " - " LEAD WIRE.

2. SPECIFICATION:

$$V_{CE(sat)} = 0.5V \text{ MAX}$$

$$V_{FG} = 5.0V \text{ TYP. } (V_{CC} \text{ MAX.})$$

$$I_c = 10mA \text{ MAX.}$$

$$R \geq V_{FG} / I_c$$

3. FREQUENCY GENERATOR WAVEFORM:

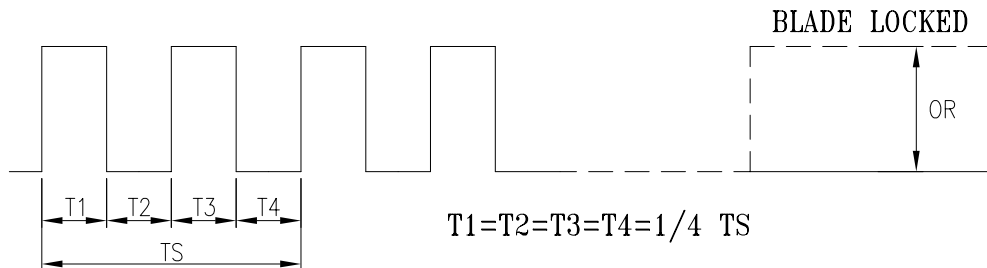
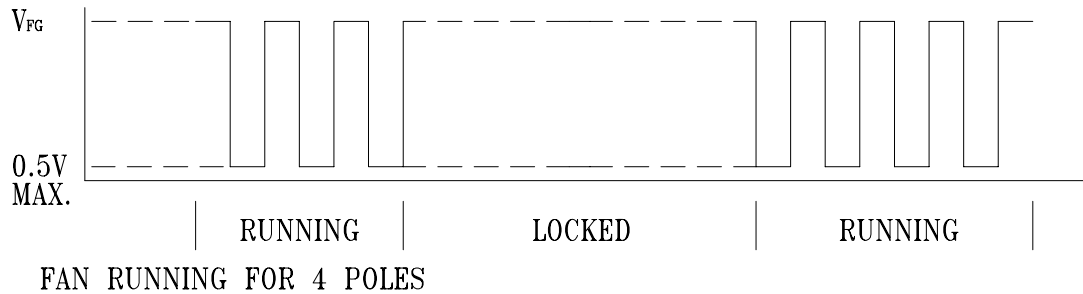

$$N = \text{R.P.M}$$

$$TS = 60 / N (\text{SEC})$$

\*VOLTAGE LEVEL AFTER BLADE LOCKED

\*4 POLES

-----  
PART NO:

-----  
DELTA MODEL:       AUC0912D-8H79  
-----

### 11. PWM CONTROL FUNCTION:(FAN ON SINK)

#### 11-1 SIGNAL DESCRIPTION:

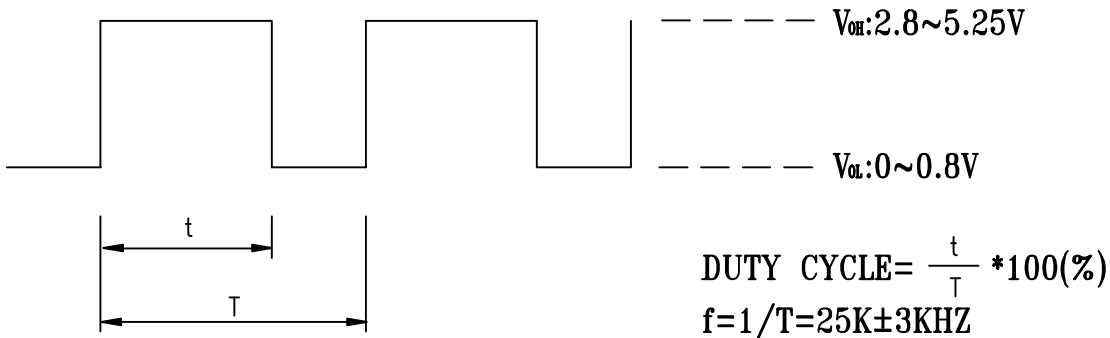

- AT 25K HZ 30% DUTY CYCLE ,THE FAN WILL BE ABLE TO START FROM A DEAD STOP .

#### 11-2 SPEED CONTROL

TEST CONDITION : INPUT VCC=12V PWM FREQUENCY=25KHZ

##### 11-2-1 TEMPERATURE CONTROL

BELOW 30 DEGREE C,THE FAN SPEED IS 2000RPM.

ABOVE 38 DEGREE C,THE FAN SPEED IS 3150RPM.

BETWEEN 30~38 DEGREE C,THE FAN SPEED IS 2000RPM~3150RPM.

##### 11-2-2 PWM CONTROL

BELOW 30 DEGREE C

BETWEEN 0%~20% TO 100% DUTY CYCLE,THE FAN SPEED IS 1000RPM TO 2000RPM.

ABOVE 38 DEGREE C

BETWEEN 0%~20% TO 100% DUTY CYCLE,THE FAN SPEED IS 1000RPM TO 3150RPM.

TEMPERATURE (°C)	DUTY CYCLE (%)	SPEED (R.P.M.)
30	0~20	1000±200
30	100	2000±10%
38	0~20	1000±200
38	100	3150±10%

- IF THE CONTROL SIGNAL IS DISCONNECT THE FAN WILL GO TO TEMPERATURE CONTROL SPEED.

PART NO:

DELTA MODEL: AUC0912D-8H79

## 12. PWM CONTROL FUNCTION:(FAN ONLY)

### 12-1 SIGNAL DESCRIPTION:

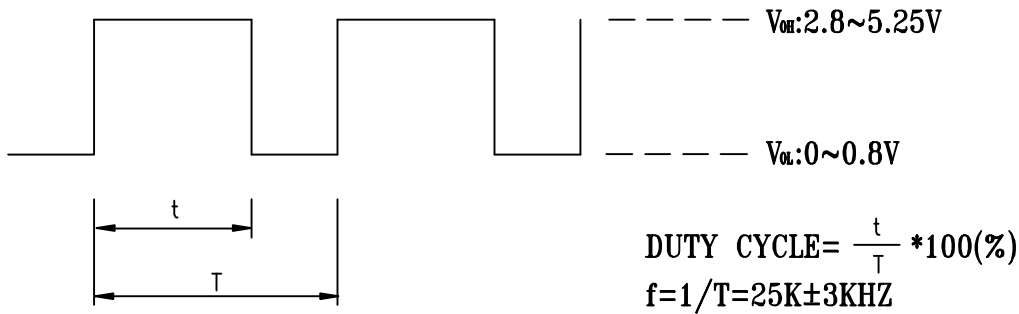

- AT 25K HZ 30% DUTY CYCLE ,THE FAN WILL BE ABLE TO START FROM A DEAD STOP .

### 12-2 SPEED CONTROL

TEST CONDITION : INPUT VCC=12V PWM FREQUENCY=25KHZ

#### 12-2-1 TEMPERATURE CONTROL

BELOW 30 DEGREE C,THE FAN SPEED IS 2000RPM.

ABOVE 38 DEGREE C,THE FAN SPEED IS 3200RPM.

BETWEEN 30~38 DEGREE C,THE FAN SPEED IS 2000RPM~3200RPM.

#### 12-2-2 PWM CONTROL

BELOW 30 DEGREE C

BETWEEN 0%~20% TO 100% DUTY CYCLE,THE FAN SPEED IS 1050RPM TO 2000RPM.

ABOVE 38 DEGREE C

BETWEEN 0%~20% TO 100% DUTY CYCLE,THE FAN SPEED IS 1050RPM TO 3200RPM.

TEMPERATURE (°C)	DUTY CYCLE (%)	SPEED (R.P.M.)
30	0~20	1050±200
30	100	2000±10%
38	0~20	1050±200
38	100	3200±10%

- IF THE CONTROL SIGNAL IS DISCONNECT THE FAN WILL GO TO TEMPERATURE CONTROL SPEED.

## 13. PWM CONTROL LEAD WIRE INPUT IMPEDANCE:

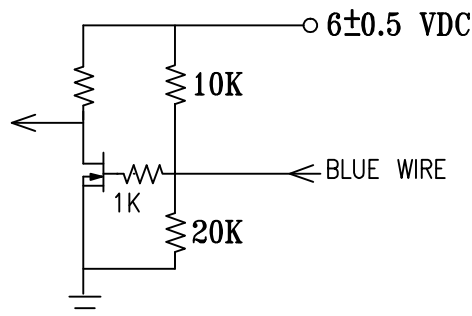





## **Descriptions:**

- 1. Delta will not guarantee the performance of the products if the application condition falls outside the parameters set forth in the specification.**
- 2. A written request should be submitted to Delta prior to approval if deviation from this specification is required.**
- 3. Please exercise caution when handling fans. Damage may be caused when pressure is applied to the impeller, if the fans are handled by the lead wires, or if the fans are hard-dropped to the production floor.**
- 4. Except as pertains to some special designs, there is no guarantee that the products will be free from any such safety problems or failures as caused by the introduction of powder, droplets of water or encroachment of insect into the hub.**
- 5. The above-mentioned conditions are representative of some unique examples and viewed as the first point of reference prior to all other information.**
- 6. It is very important to establish the correct polarity before connecting the fan to the power source. Positive (+) and Negative (-). Damage may be caused to the fans if connection is with reverse polarity, as there is no foolproof method to protect against such error.**
- 7. Delta fans are not suitable where any corrosive fluids are introduced to their environment.**
- 8. Please ensure all fans are stored according to the storage temperature limits specified. Do not store fans in a high humidity environment. We highly recommend performance testing is conducted before shipping, if the fans have been stored over 6 months.**
- 9. Not all fans are provided with the Lock Rotor Protection feature. If you impair the rotation of the impeller for the fans that do not have this function, the performance of those fans will lead to failure.**
- 10. Please be cautious when mounting the fan. Incorrect mounting of fans may cause excess resonance, vibration and subsequent noise.**
- 11. It is important to consider safety when testing the fans. A suitable fan guard should be fitted to the fan to guard against any potential for personal injury.**
- 12. Except where specifically stated, all tests are carried out at relative (ambient) temperature and humidity conditions of 25°C, 65%. The test value is only for fan performance itself.**
- 13. Be certain to connect an “over 4.7µF” capacitor to the fan externally when the application calls for using multiple fans in parallel, to avoid any unstable power.**