

QUICK START GUIDE FOR DEMONSTRATION CIRCUIT 502

1.25MHZ WIDE INPUT RANGE STEP DOWN DC/DC CONVERTER

LT1767

DESCRIPTION

Demonstration circuit 502 is a 1.25MHz 1.5A monolithic step-down DC/DC switching converter using the LT1767 buck regulator. With its fast switching speed, 1.5A internal power switch, and wide input voltage range, the LT1767 is a very versatile and powerful IC for DC/DC converters that require compact space and a wide variety of input voltage ranges. The constant 1.25MHz switching frequency allows all of the components to be very small, surface mount devices. The current-mode control topology creates fast transient response and good loop stability with a minimum number of external compensation components and ceramic input and output capacitors. The low resistance internal power switch (0.22Ω) maintains high efficiencies $>80\%$ and up to 90% . The SHDN pin and 6uA shutdown current extends battery life. The wide V_{IN} range of the LT1767 allows step-down configurations from $3V_{in}$ up to $25V_{in}$. Synchronization of switching frequencies up to 2MHz is possible.

Demonstration Circuit 502 is a step-down converter using the LT1767EMS8E. The circuit is designed for 6.6-25V

input to 5.0V output @1A or for 4.5-25V[†] input to 3.3V output @1A for cable modem, handheld, automotive, and desktop computer applications. The output voltage is jumper selectable (5V or 3.3V). This board was designed for wide input voltage range applications where simplicity, small circuit size, and low component count are important as well as up to 1A of load current. The use of ceramic capacitors not only demonstrates small size and low cost, but the advantage of current-mode control in step-down applications with a simple compensation network and a place-holder for a feedforward capacitor for more rugged stability and optimal transient response if required.

Design files for this circuit board are available. Call the LTC factory.

[†]Higher input voltages may pulse-skip due to minimum on-time restrictions. Compensation component changes may be necessary to optimize pulse-skipping during high-temperature, high-voltage conditions and maintain control of switch current.

Table 1. Typical Performance Summary

PARAMETER	CONDITION	VALUE
Input Voltage Range	$V_{out} = 5V$ (Jumper Selection)	6.6V-25V
Input Voltage Range	$V_{out} = 3.3V$ (Jumper Selection)	4.5V-18V
V_{out}	$V_{out} = 5V$ (Jumper Selection)	5V $\pm 3\%$
V_{out}	$V_{out} = 3.3V$ (Jumper Selection)	3.3V $\pm 3\%$
Maximum Output Current		1A
Typical Switching Frequency		1.25MHz
Typical Efficiency	$V_{in} = 12V, V_{out} = 5V, I_{out} = 1A$	84%

QUICK START GUIDE FOR DEMONSTRATION CIRCUIT 502

1.25MHZ WIDE INPUT RANGE STEP DOWN DC/DC CONVERTER

QUICK START PROCEDURE

Demonstration circuit 502 is easy to set up to evaluate the performance of the LT1767. Refer to Figure 1 for proper measurement equipment setup and follow the procedure below:

NOTE: Make sure that the input voltage does not exceed 25V.

1. Connect the 7V-25V or 4.5V-18V input power supply to the Vin and Gnd terminals on the board.
2. Connect an ammeter in series with the input supply to measure input current.
3. Connect either power resistors or an electronic load to the Vout and Gnd terminals on the board.
4. Connect an ammeter in series with output load to measure output current.
5. Connect a voltmeter across the Vin and Gnd terminals to measure input voltage.
6. Connect a voltmeter across the Vout and Gnd terminal to measure output voltage.
7. After all connections are made, turn on input power and verify that the output voltage is either 5.0V or 3.3V (the output voltage jumper setting).
8. The synchronization and shutdown functions are optional and their pins can be left floating (disconnected) if their functions are not being used.

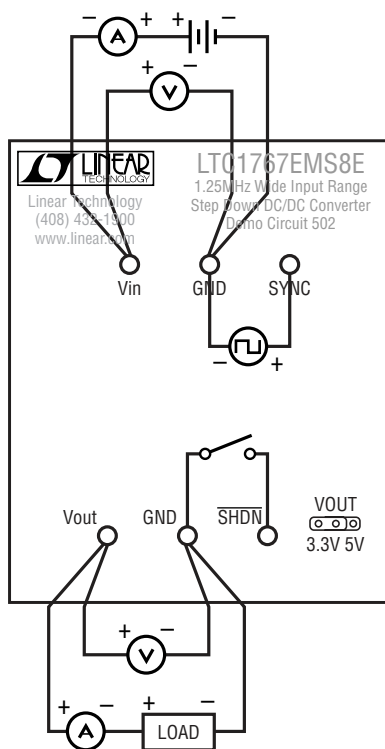

Figure 1. Proper Measurement Equipment Setup

QUICK START GUIDE FOR DEMONSTRATION CIRCUIT 502

1.25MHz WIDE INPUT RANGE STEP DOWN DC/DC CONVERTER

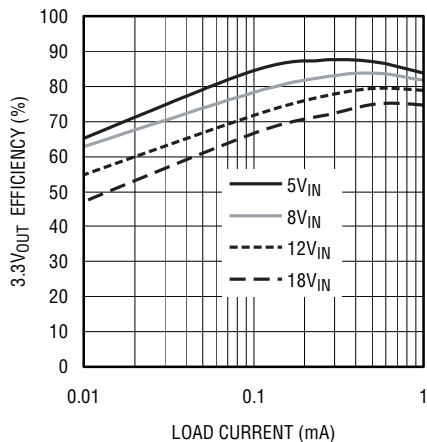

Figure 2. Efficiency for $V_{OUT} = 3.3V$

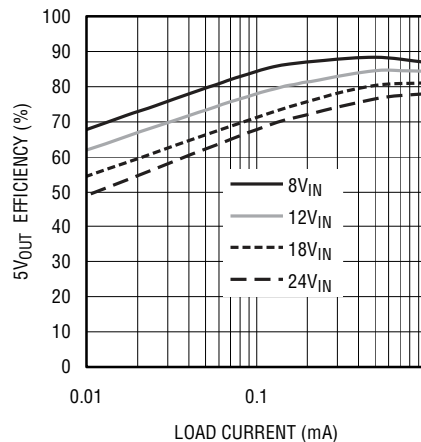

Figure 3. Efficiency for $V_{OUT} = 5V$

MINIMUM INPUT VOLTAGE

The minimum LT1767 operating input voltage is 3.0V. However, a DC/DC buck converter needs to have an input voltage greater than the output voltage by a certain margin in order to provide the desired regulated output voltage. Maximum duty cycle, switch on-resistance, and inductor and diode DC losses all play a part in determining the minimum input voltage for a selected output over the full current range of the application. For this demonstration board, with up to 1A output current, the minimum input voltages required to maintain regulated output voltages is listed below. Customizable output voltages 2.5V and 1.8V are very common and are thus additionally listed in the table (see *Customizing the Board* below). If the input voltage falls below the minimum input voltage listed below, the output voltage can drop accordingly from the programmed output

voltage. This mode is called maximum duty cycle drop-out.

Table 2. Minimum Input Voltage for Regulated Output

V_{OUT}	V_{IN} (MINIMUM)
5.0V	6.6V
3.3V	4.5V
2.5V	3.5V
1.8V	3.0V

CUSTOMIZING THE BOARD

The components built on the board are optimized for a wide input voltage range. The bandwidth can be increased for more specific input voltages such as $12V \pm 10\%$ or $5V \pm 10\%$ if desired. Some typical applications with typical input voltage ranges that are smaller than the wide input voltage range of the part are included below. The adjustable feedback resistors allow the output voltage to be customized. For output voltages below 3.0V, the boost diode should be moved from D2 to D3 to provide the minimum boost

QUICK START GUIDE FOR DEMONSTRATION CIRCUIT 502

1.25MHz WIDE INPUT RANGE STEP DOWN DC/DC CONVERTER

voltage required for the internal power switch. Make sure that the boost capacitor (C8) has a voltage rating greater than or equal to the output voltage for applications where

the boost diode is placed in D2. However, the boost capacitor must have a voltage rating greater than the input voltage whenever the boost diode is placed in position D3.

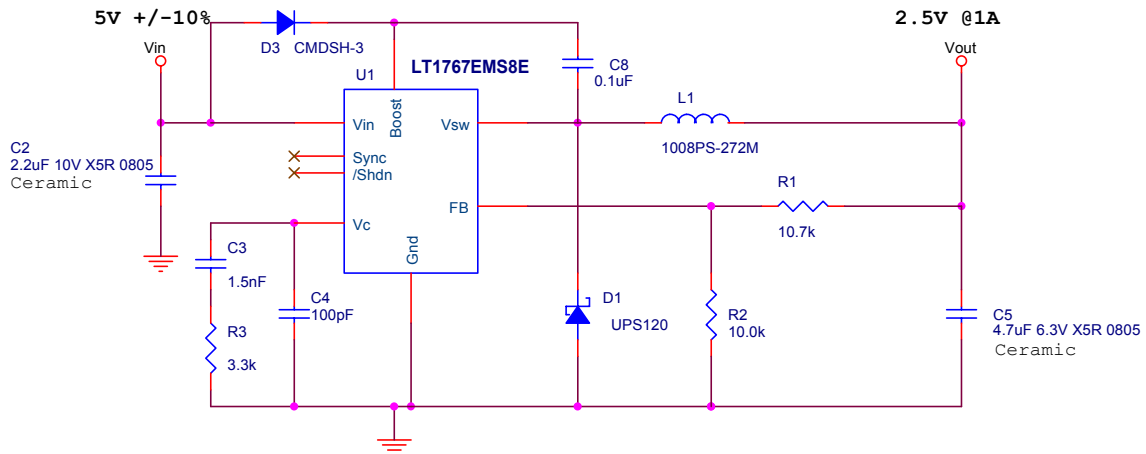
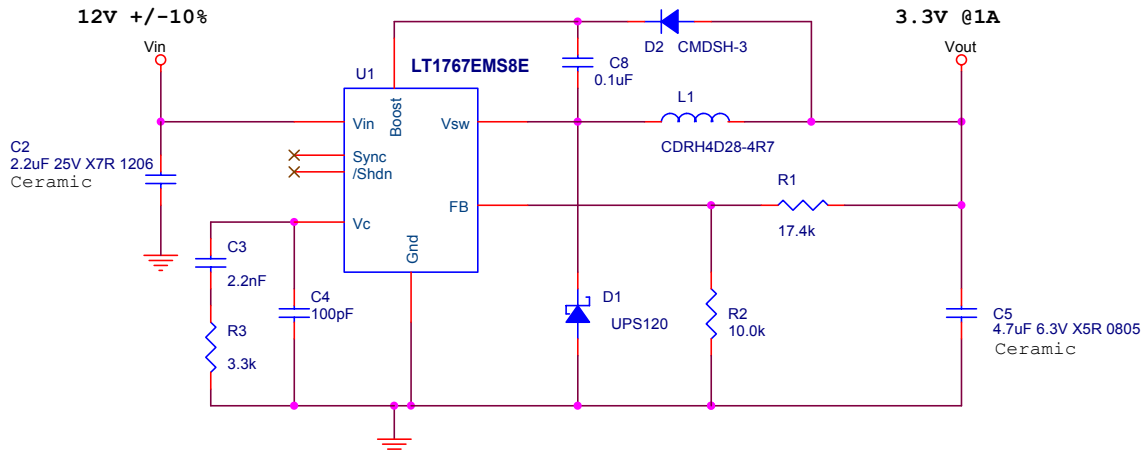
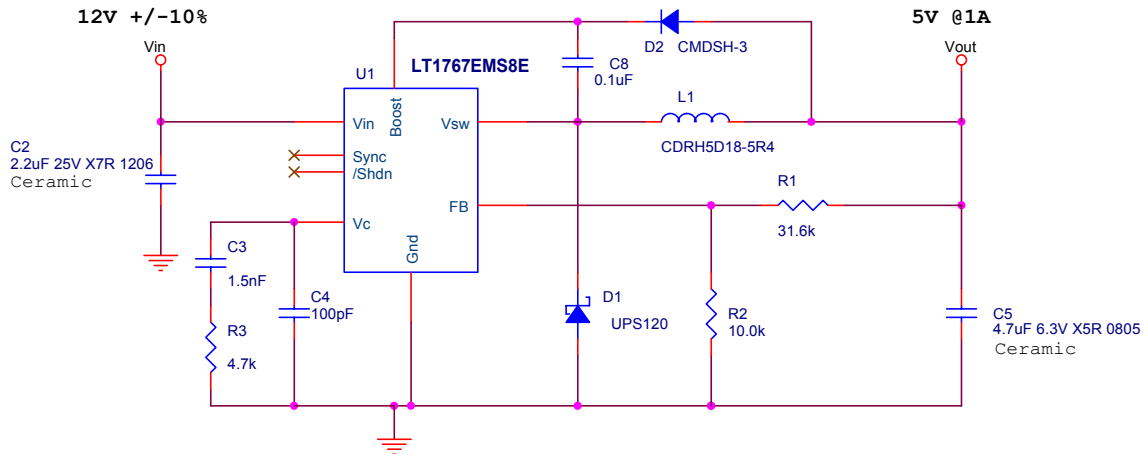

QUICK START GUIDE FOR DEMONSTRATION CIRCUIT 502

1.25MHz WIDE INPUT RANGE STEP DOWN DC/DC CONVERTER

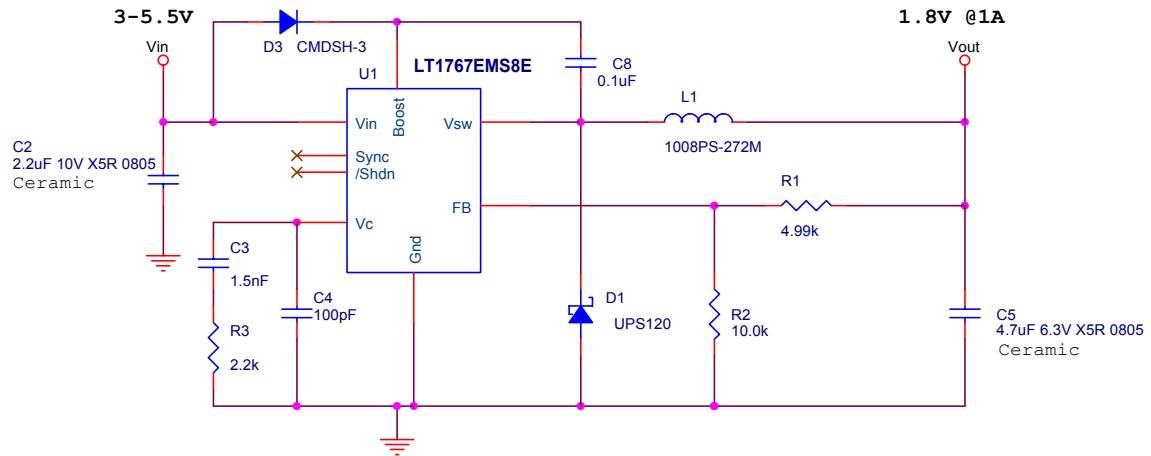

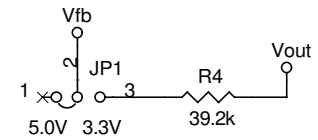
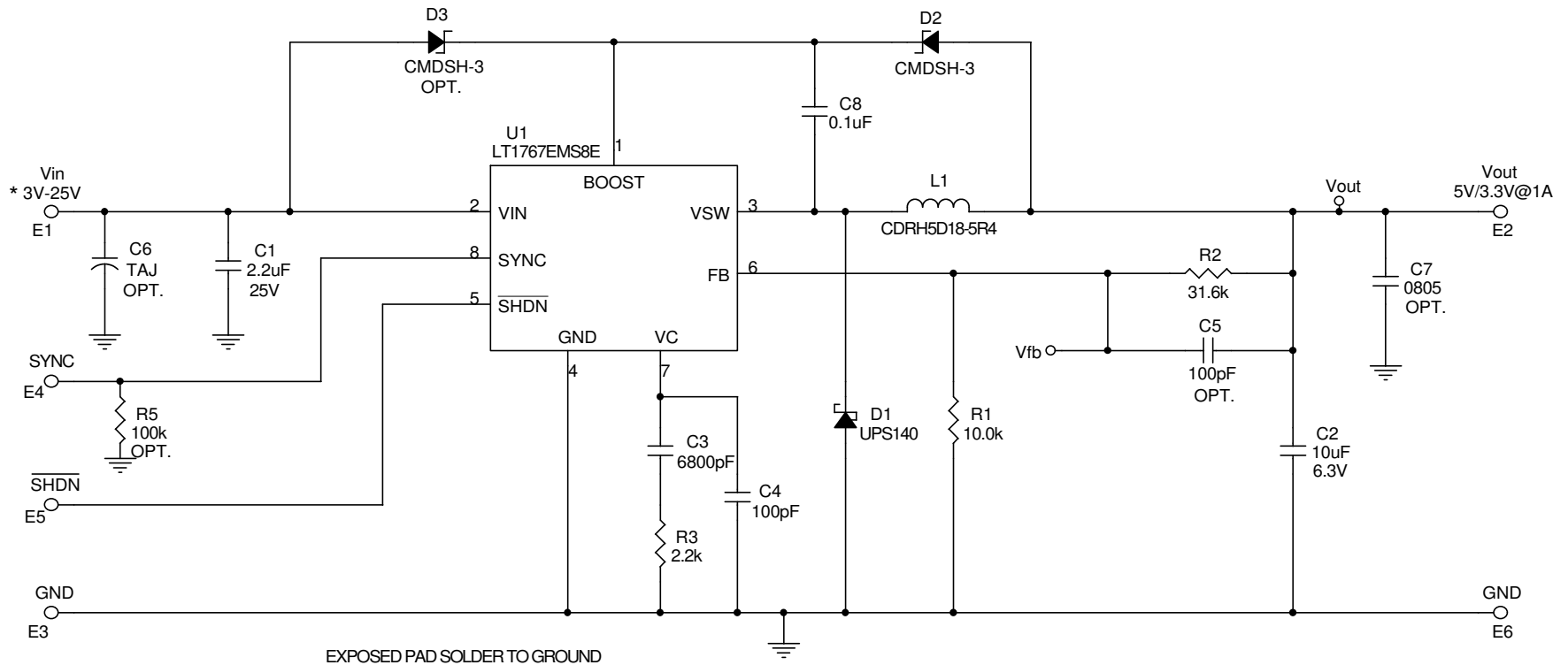

* VIN MINIMUM	VOUT
6.6	5
4.5	3.3
3.5	2.5
3	1.8

See Quick-Start Guide.

CONTRACT NO.		 1630 McCarthy Blvd. Milpitas, CA 95035 Phone: (408)432-1900 Fax: (408)434-0507	
APPROVALS	DATE		
DRAWN	June Wu	2/12/02	TITLE
CHECKED			LT1767EMS8E, 1.25MHz Wide Input Range Step Down DC/DC Converter
APPROVED			SIZE
ENGINEER	Keith S.	2/12/02	CAGE CODE
DESIGNER			DWG NO
			DC502A
			REV
			A
Tuesday, August 06, 2002		SCALE:	FILENAME:
		SHEET	1 OF 1

Item	Qty	Reference	Part Description	Manufacture / Part #
1	1	C1	CAP., X7R, 2.2uF, 25V, 10% 1206	TDK, C3216X7R1E225K
2	1	C2	CAP., X5R, 10uF, 6.3V, 20% 0805	TDK, C2010X5R0J106M
3	1	C3	CAP., X7R, 6800pF, 50V, 20% 0603	AVX, 06035C682MAT2A
4	1	C4	CAP., NPO, 100pF, 50V, 10% 0603	AVX, 06035A101KAT2A
5	0	C5 (OPT.)	CAP., 100pF, 0603	
6	0	C6 (OPT.)		
7	0	C7 (OPT.)	CAP., 0805	
8	1	C8	CAP., X7R, 0.1uF, 16V, 20% 0603	Taiyo Yuden, EMK107BJ104MA
9	1	D1	Schottky Barrier REC., UPS140	MICROSEMI., UPS140
10	1	D2	DIODE, CMDSH-3, SOD-323	CENTRAL SEMI., CMDSH-3
11	0	D3 (OPT.)	DIODE, CMDSH-3, SOD-323	CENTRAL SEMI., CMDSH-3
12	6	E1-E6	TURRET,	MILL-MAX 2501-2
13	2	JP1,JP2	0.079 SINGLE ROW HEADER, 3 PIN	COMM CON, 2802S-03-G1
14	1	JP1	SHUNT,	COMM CON, CCIJ2MM-138G
15	1	L1	INDUCTOR, 5.4uH	SUMIDA, CDRH5D18-5R4
16	1	R1	RES.,CHIP, 10.0K, 1/16W, 5% 0603	AAC, CR16-103JM
17	1	R2	RES.,CHIP, 31.6K, 1/16W, 1% 0603	AAC, CR16-3162FM
18	1	R3	RES.,CHIP, 2.2K, 1/16W, 5% 0603	AAC, CR16-222JM
19	1	R4	RES.,CHIP, 39.2K, 1/16W, 5% 0603	AAC, CR16-3922FM
20	0	R5 (OPT.)	RES., CHIIP 0603	
21	1	U1	I.C., LT1767EMS8E MS8 Exposed	Linear Tech. LT1767EMS8E
22	1		PRINTED CIRCUIT BOARD	DEMO BOARD DC502A