

April 1995

30A, 400V - 600V Hyperfast Dual Diodes

### Features

- Hyperfast with Soft Recovery . . . . . <40ns
- Operating Temperature . . . . . +175°C
- Reverse Voltage Up To . . . . . 600V
- Avalanche Energy Rated
- Planar Construction

### Applications

- Switching Power Supplies
- Power Switching Circuits
- General Purpose

### Description

RHRG3040CC, RHRG3050CC and RHRG3060CC are hyperfast diodes with soft recovery characteristics ( $t_{RR} < 40ns$ ). They have half the recovery time of ultrafast diodes and are silicon nitride passivated ion-implanted epitaxial planar construction.

These devices are intended for use as freewheeling/clamping diodes and rectifiers in a variety of switching power supplies and other power switching applications. Their low stored charge and hyperfast soft recovery minimize ringing and electrical noise in many power switching circuits reducing power loss in the switching transistors.

#### PACKAGING AVAILABILITY

PART NUMBER	PACKAGE	BRAND
RHRG3040CC	TO-247	RHRG3040C
RHRG3050CC	TO-247	RHRG3050C
RHRG3060CC	TO-247	RHRG3060C

NOTE: When ordering, use the entire part number.

Formerly developmental type TA49063.

### Package

JEDEC STYLE TO-247

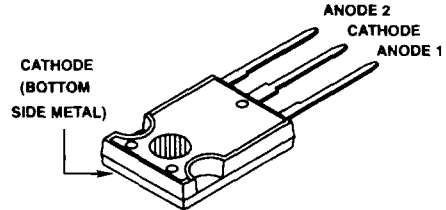

### Symbol

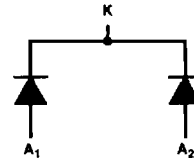

### Absolute Maximum Ratings (per leg) $T_C = +25^\circ C$ , Unless Otherwise Specified

	RHRG3040CC	RHRG3050CC	RHRG3060CC	UNITS
Peak Repetitive Reverse Voltage . . . . .	$V_{RRM}$ 400	500	600	V
Working Peak Reverse Voltage . . . . .	$V_{RWM}$ 400	500	600	V
DC Blocking Voltage . . . . .	$V_R$ 400	500	600	V
Average Rectified Forward Current . . . . .	$I_{F(AV)}$ 30	30	30	A
( $T_C = +120^\circ C$ )				
Repetitive Peak Surge Current . . . . .	$I_{FSM}$ 70	70	70	A
(Square Wave, 20kHz)				
Nonrepetitive Peak Surge Current . . . . .	$I_{FSM}$ 325	325	325	A
(Halfwave, 1 Phase, 60Hz)				
Maximum Power Dissipation . . . . .	$P_D$ 125	125	125	W
Avalanche Energy (See Figures 10 and 11) . . . . .	$E_{AVL}$ 20	20	20	mJ
Operating and Storage Temperature . . . . .	$T_{STG}, T_J$ -65 to +175	-65 to +175	-65 to +175	$^\circ C$

## Specifications RHRG3040CC, RHRG3050CC, RHRG3060CC

**Electrical Specifications** (per leg)  $T_C = +25^\circ\text{C}$ , Unless Otherwise Specified

SYMBOL	TEST CONDITION	RHRG3040CC			RHRG3050CC			RHRG3060CC			UNITS
		MIN	TYP	MAX	MIN	TYP	MAX	MIN	TYP	MAX	
$V_F$	$I_F = 30\text{A}$ , $T_C = +25^\circ\text{C}$	-	-	2.1	-	-	2.1	-	-	2.1	V
	$I_F = 30\text{A}$ , $T_C = +150^\circ\text{C}$	-	-	1.7	-	-	1.7	-	-	1.7	V
$I_R$	$V_R = 400\text{V}$ , $T_C = +25^\circ\text{C}$	-	-	500	-	-	-	-	-	-	$\mu\text{A}$
	$V_R = 500\text{V}$ , $T_C = +25^\circ\text{C}$	-	-	-	-	-	500	-	-	-	$\mu\text{A}$
	$V_R = 600\text{V}$ , $T_C = +25^\circ\text{C}$	-	-	-	-	-	-	-	-	500	$\mu\text{A}$
$I_R$	$V_R = 400\text{V}$ , $T_C = +150^\circ\text{C}$	-	-	1.0	-	-	-	-	-	-	mA
	$V_R = 500\text{V}$ , $T_C = +150^\circ\text{C}$	-	-	-	-	-	1.0	-	-	-	mA
	$V_R = 600\text{V}$ , $T_C = +150^\circ\text{C}$	-	-	-	-	-	-	-	-	1.0	mA
$t_{RR}$	$I_F = 1\text{A}$ , $di_F/dt = 200\text{A}/\mu\text{s}$	-	-	40	-	-	40	-	-	40	ns
	$I_F = 30\text{A}$ , $di_F/dt = 200\text{A}/\mu\text{s}$	-	-	45	-	-	45	-	-	45	ns
$t_A$	$I_F = 30\text{A}$ , $di_F/dt = 200\text{A}/\mu\text{s}$	-	22	-	-	22	-	-	22	-	ns
$t_B$	$I_F = 30\text{A}$ , $di_F/dt = 200\text{A}/\mu\text{s}$	-	18	-	-	18	-	-	18	-	ns
$Q_{RR}$	$I_F = 30\text{A}$ , $di_F/dt = 200\text{A}/\mu\text{s}$	-	100	-	-	100	-	-	100	-	nC
$C_J$	$V_R = 10\text{V}$ , $I_F = 0\text{A}$	-	85	-	-	85	-	-	85	-	pF
$R_{\theta JC}$		-	-	1.2	-	-	1.2	-	-	1.2	$^\circ\text{C}/\text{W}$

### DEFINITIONS

- $V_F$  = Instantaneous forward voltage (pw = 300 $\mu\text{s}$ , D = 2%).
- $I_R$  = Instantaneous reverse current.
- $t_{RR}$  = Reverse recovery time (See Figure 2), summation of  $t_A + t_B$ .
- $t_A$  = Time to reach peak reverse current (See Figure 2).
- $t_B$  = Time from peak  $I_{RM}$  to projected zero crossing of  $I_{RM}$  based on a straight line from peak  $I_{RM}$  through 25% of  $I_{RM}$  (See Figure 2).
- $Q_{RR}$  = Reverse recovery charge.
- $C_J$  = Junction Capacitance.
- $R_{\theta JC}$  = Thermal resistance junction to case.
- $E_{AVL}$  = Controlled avalanche energy. (See Figures 10 and 11).
- pw = pulse width.
- D = duty cycle.

$V_1$  AMPLITUDE CONTROLS  $I_F$   
 $V_2$  AMPLITUDE CONTROLS  $di_F/dt$   
 $L_1$  = SELF INDUCTANCE OF  
 $R_4 + L_{\text{LOOP}}$

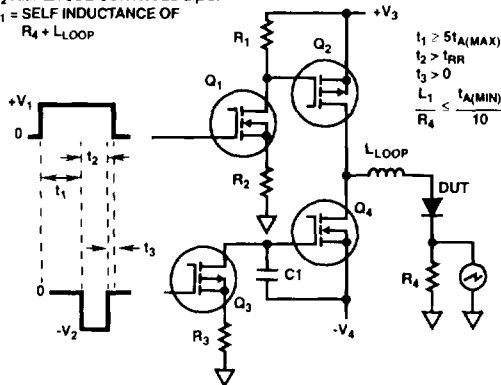

FIGURE 1.  $t_{RR}$  TEST CIRCUIT

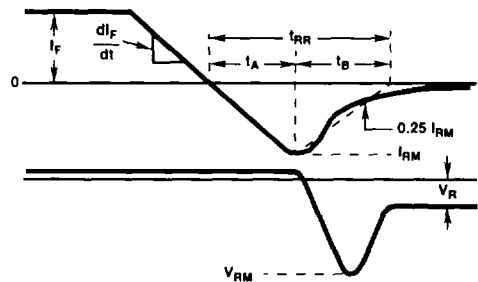

FIGURE 2.  $t_{RR}$  WAVEFORMS AND DEFINITIONS

Typical Performance Curves

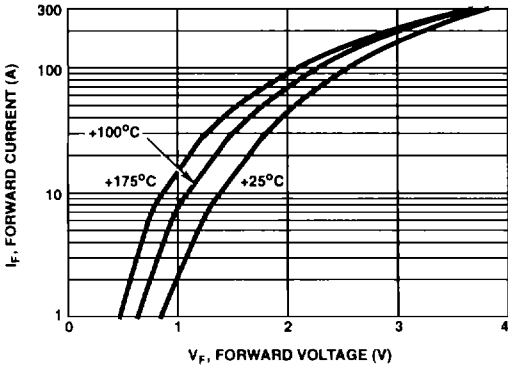

FIGURE 3. TYPICAL FORWARD CURRENT vs FORWARD VOLTAGE DROP

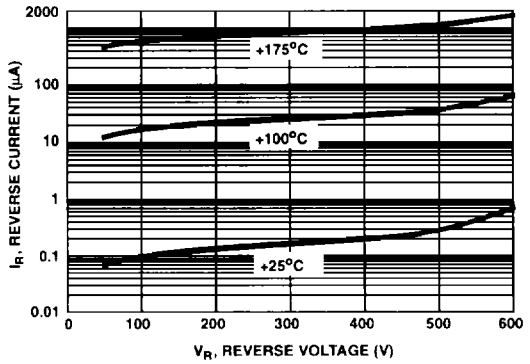

FIGURE 4. TYPICAL REVERSE CURRENT vs REVERSE VOLTAGE

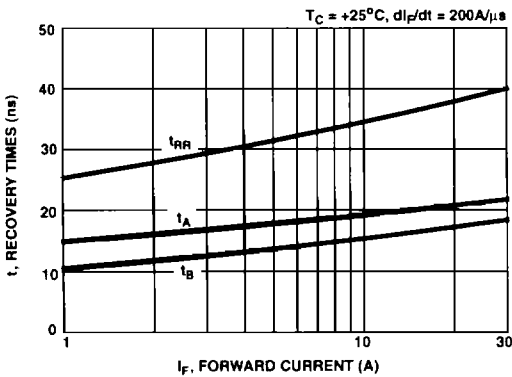

FIGURE 5. TYPICAL  $t_{RR}$ ,  $t_A$  AND  $t_B$  CURVES vs FORWARD CURRENT AT +25°C

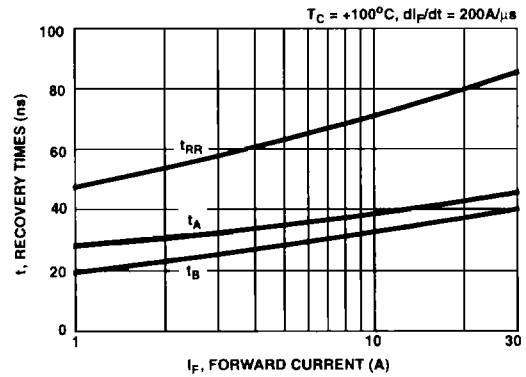

FIGURE 6. TYPICAL  $t_{RR}$ ,  $t_A$  AND  $t_B$  CURVES vs FORWARD CURRENT AT +100°C

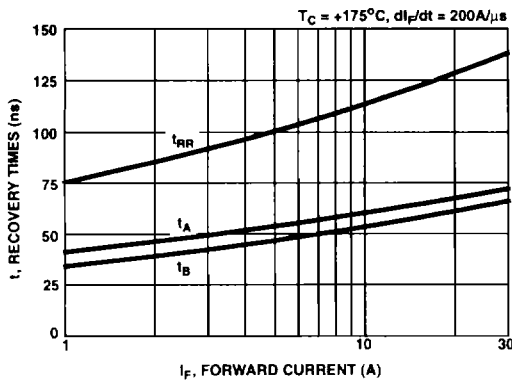

FIGURE 7. TYPICAL  $t_{RR}$ ,  $t_A$  AND  $t_B$  CURVES vs FORWARD CURRENT AT +175°C

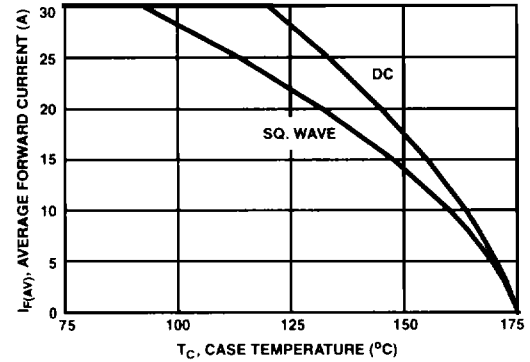

FIGURE 8. CURRENT DERATING CURVE FOR ALL TYPES

8  
HYPERFAST  
DUAL DIODES

Typical Performance Curves (Continued)

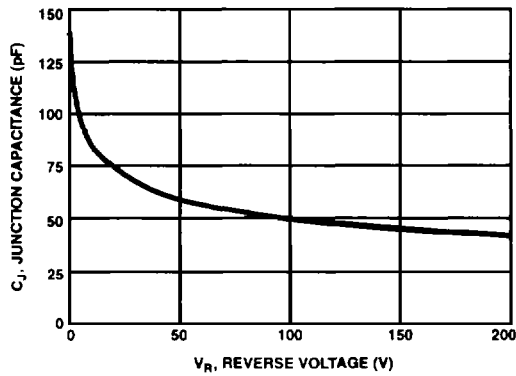

FIGURE 9. TYPICAL JUNCTION CAPACITANCE vs REVERSE VOLTAGE

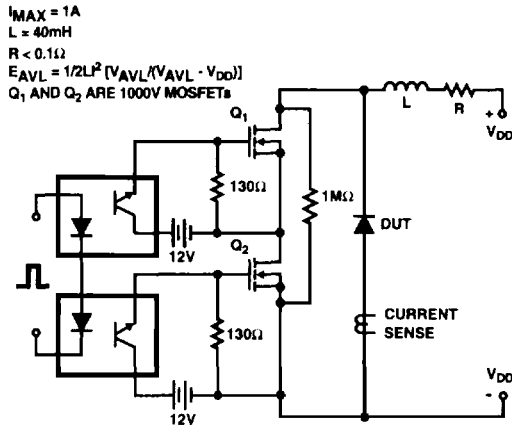

FIGURE 10. AVALANCHE ENERGY TEST CIRCUIT

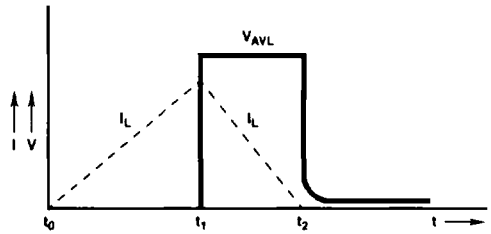

FIGURE 11. AVALANCHE CURRENT AND VOLTAGE WAVEFORMS