

BASE CAGE DETAILS

1000141242

SHOWN

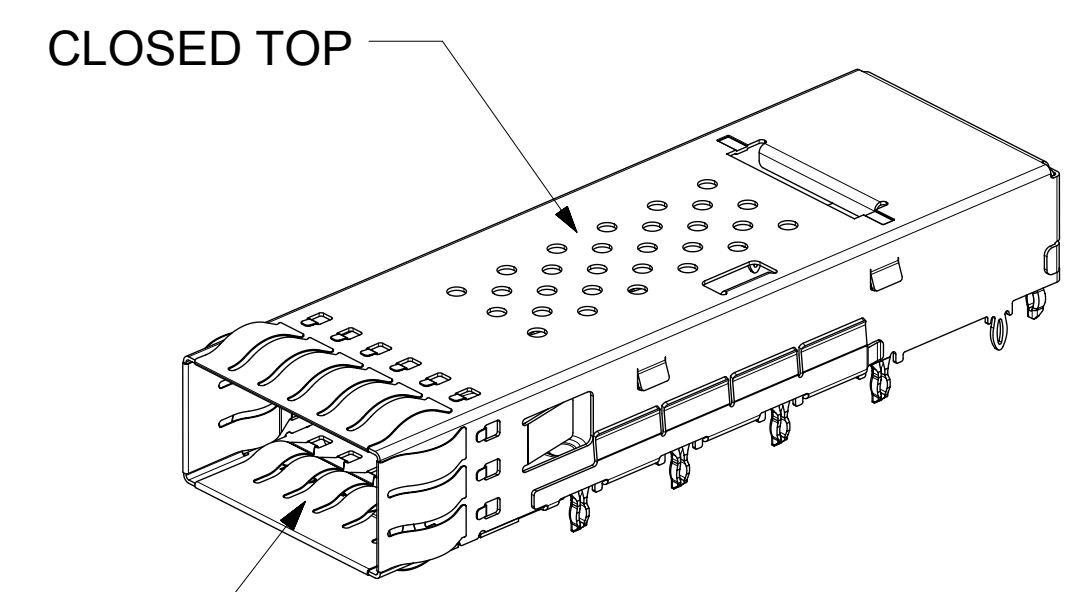
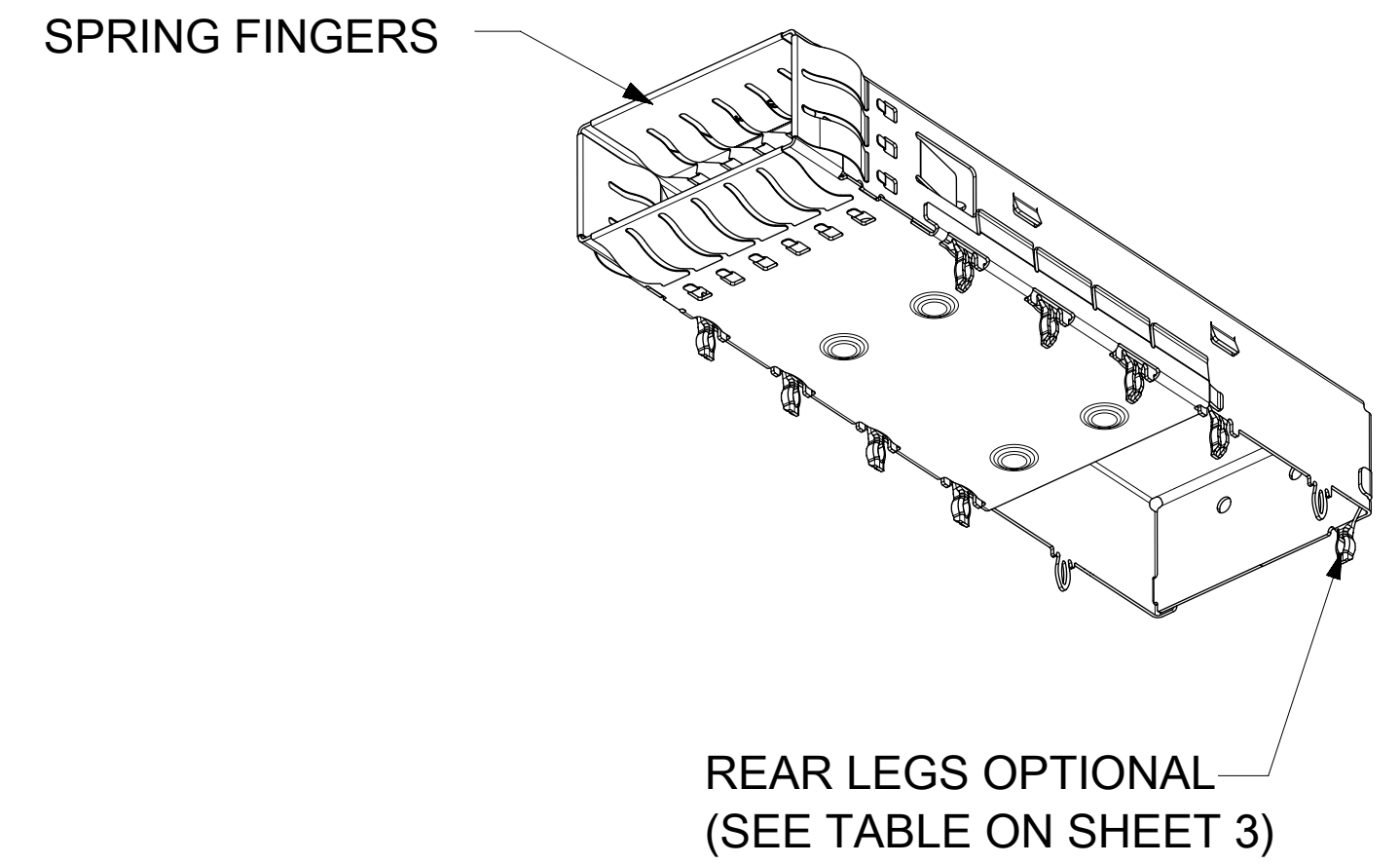
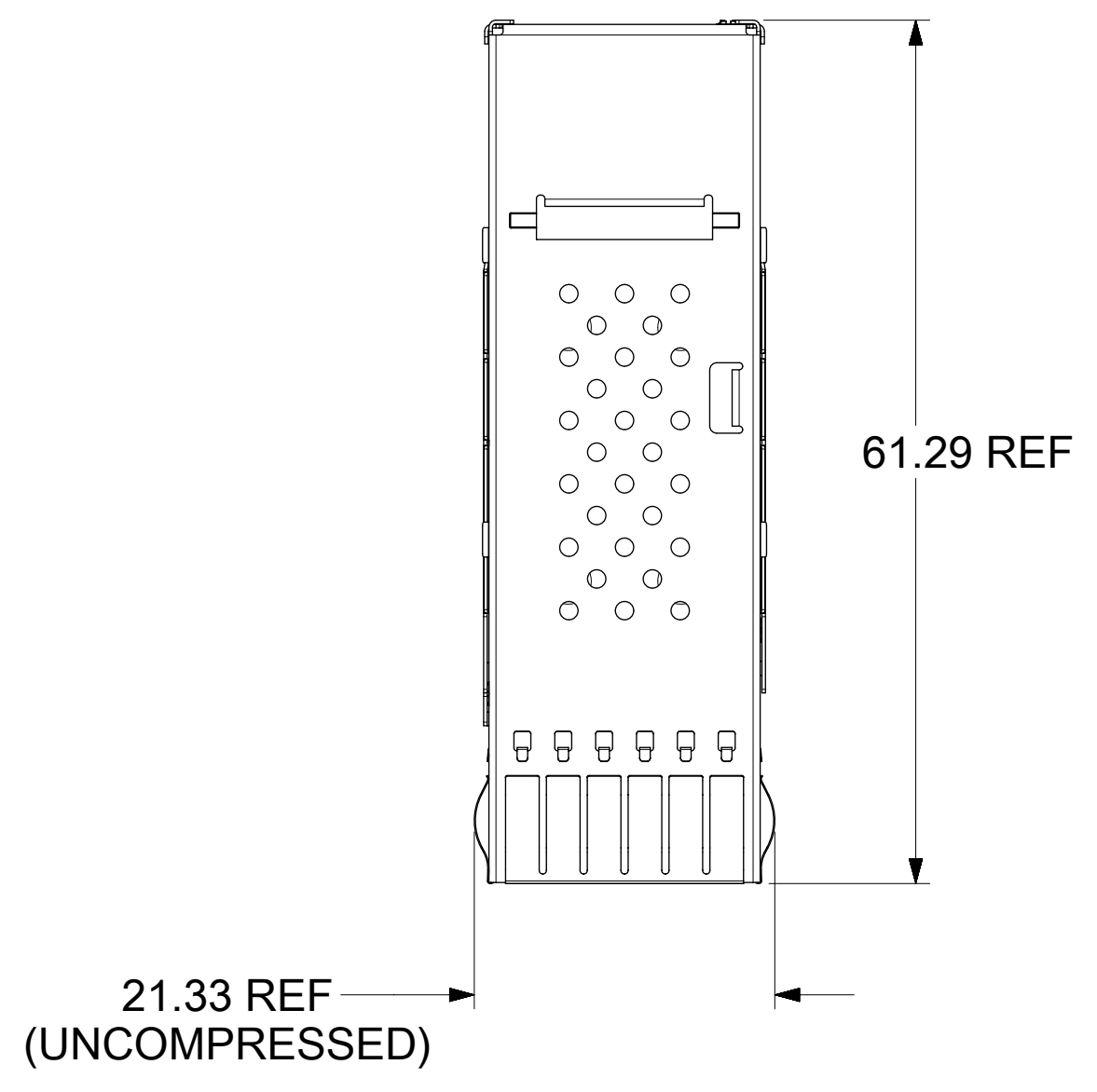

DIMENSIONS OF EACH INNER CAGE DESIGNED TO FUNCTION WITH QUAD SMALL FORM-FACTOR (zQSFP+) TRANSCEIVER

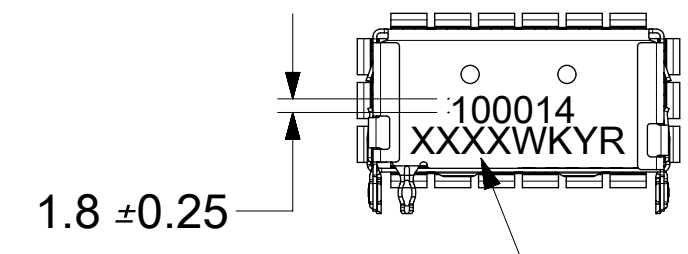
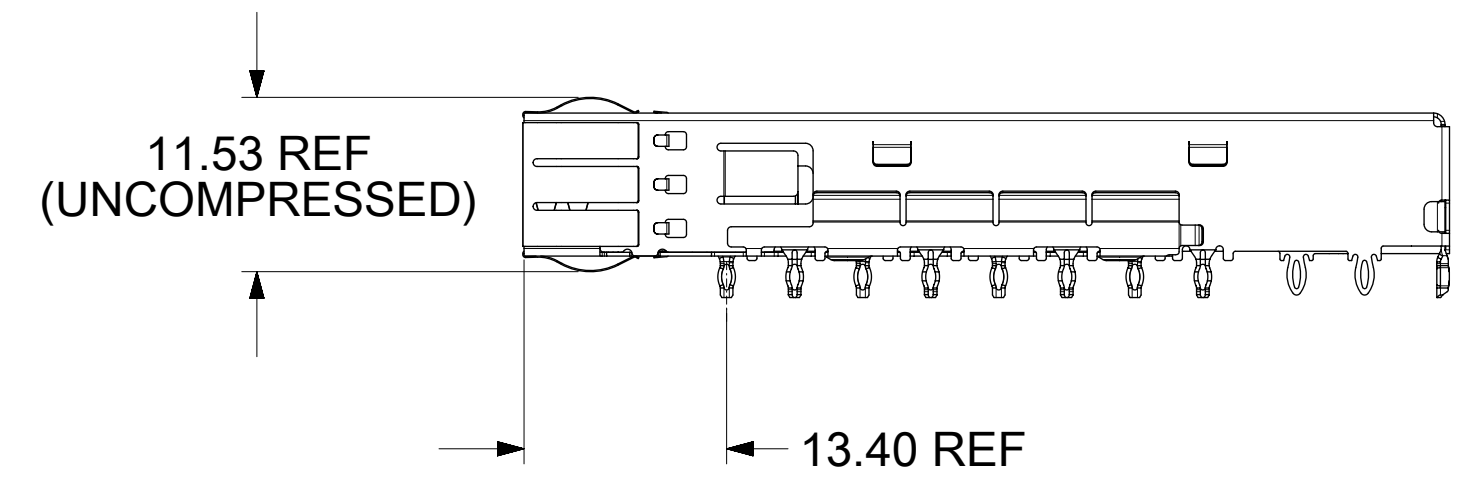
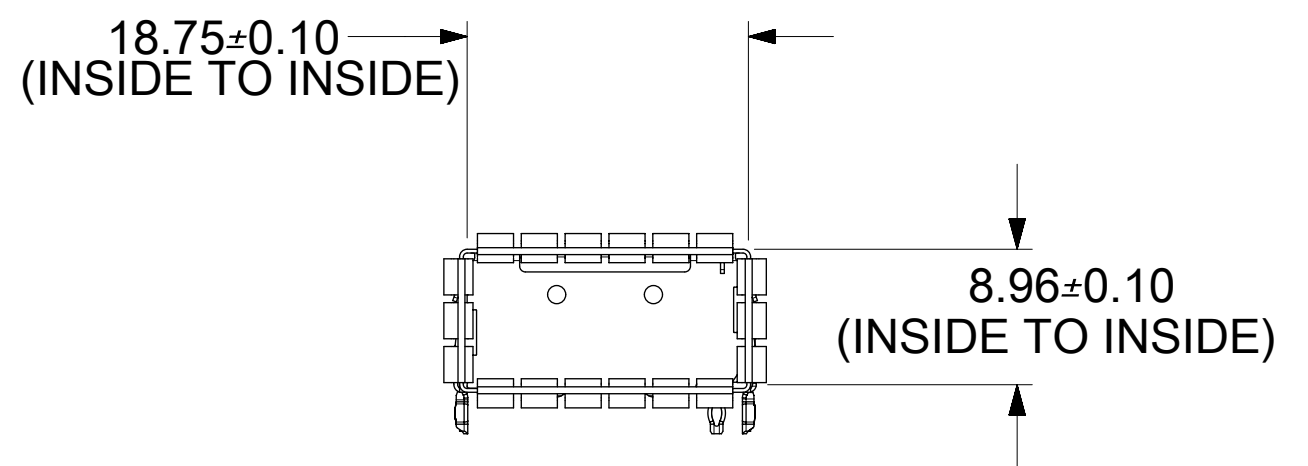

P/N AND WEEK/YEAR DATE CODE TO BE PRINTED ON BACK OF COMPLETED CAGE ASSEMBLY APPROXIMATELY AS SHOWN. SEE TABLE BELOW FOR DATE CODE INFORMATION.

- NOTES:**
- MATERIAL: CAGE: STAINLESS STEEL
 SPRING FINGERS: BERYLLIUM COPPER; NICKEL PLATED
 HEAT SINKS: NICKEL PLATED ALUMINUM
 HEAT SINK CLIP: STAINLESS STEEL
 LIGHT PIPES: POLYCARBONATE (UL 94-V-0)
 - DIMENSIONS MARKED ∇ ARE CRITICAL TO FUNCTION OF THE PART AND MUST BE INSPECTED
 - DRAWING APPLIES TO ALL P/N'S SHOWN ON PAGE 3
 - DURING FINAL INSPECTION, CAGE LEG LOCATIONS AND STRAIGHTNESS MUST BE CHECKED USING APPROPRIATE GO - NO GO GAGE
 - DURING FINAL INSPECTION, CAGE MUST BE INSPECTED TO MAKE SURE LEG CONFIGURATIONS AND PART NUMBERS ARE CORRECT, USE SHEETS 3, 4 AND 5
 - PARTS TO BE INSPECTED PER MOLEX COSMETIC SPEC WI-HP-7-2774 (CLASS B UNLESS OTHERWISE SPECIFIED)
 - PRESS-FIT LEGS 2.44 [0.096] LONG -
 1.57 [0.062] MINIMUM PCB THICKNESS FOR SINGLE SIDED USE.
 3.00 [0.118] MINIMUM PCB THICKNESS FOR BELLY TO BELLY USE.
 - NO RoHS EXEMPTIONS

WEEK/YEAR DATE CODE TABLE	
WK	WEEK OF THE YEAR 01 THRU 52 (EXAMPLE: 01= FIRST WEEK OF YEAR 52= LAST WEEK OF YEAR)
YR	18, 19, 20 ETC.. (EXAMPLE: YEAR 2018= 18)

THIS DRAWING CONTAINS INFORMATION THAT IS PROPRIETARY TO MOLEX ELECTRONIC TECHNOLOGIES, LLC AND SHOULD NOT BE USED WITHOUT WRITTEN PERMISSION			
DIMENSION UNITS	SCALE	CURRENT REV DESC: SEE REVISION TABLE	
mm	2:1		
GENERAL TOLERANCES (UNLESS SPECIFIED)		EC NO: 623918	
ANGULAR TOL	± 2.0°	DRWN: VLOKESHA	2019/08/23
4 PLACES	±	CHK'D: JYEN01	2019/09/11
3 PLACES	±	APPR: JCHIANG	2019/09/11
2 PLACES	± 0.13	INITIAL REVISION:	
1 PLACE	± 0.25	DRWN: PGSHETTY	2015/10/21
0 PLACES	±	APPR: RCHEN08	2015/11/16
DRAFT WHERE APPLICABLE MUST REMAIN WITHIN DIMENSIONS		THIRD ANGLE PROJECTION	DRAWING SERIES
			D-SIZE 100014
		MATERIAL NUMBER	CUSTOMER
		SEE DRAWING	GENERAL MARKET
		DOCUMENT NUMBER	DOC TYPE DOC PART REVISION
		1000141200	PSD ASY L1
		SHEET NUMBER	
		1 OF 8	

CAGE ASSEMBLY OPTIONS

1000141544

SHOWN

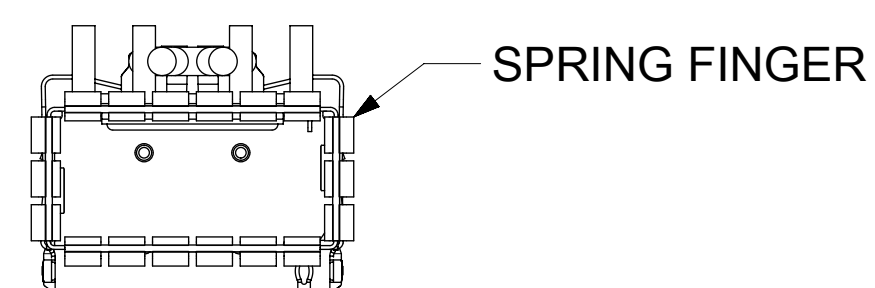
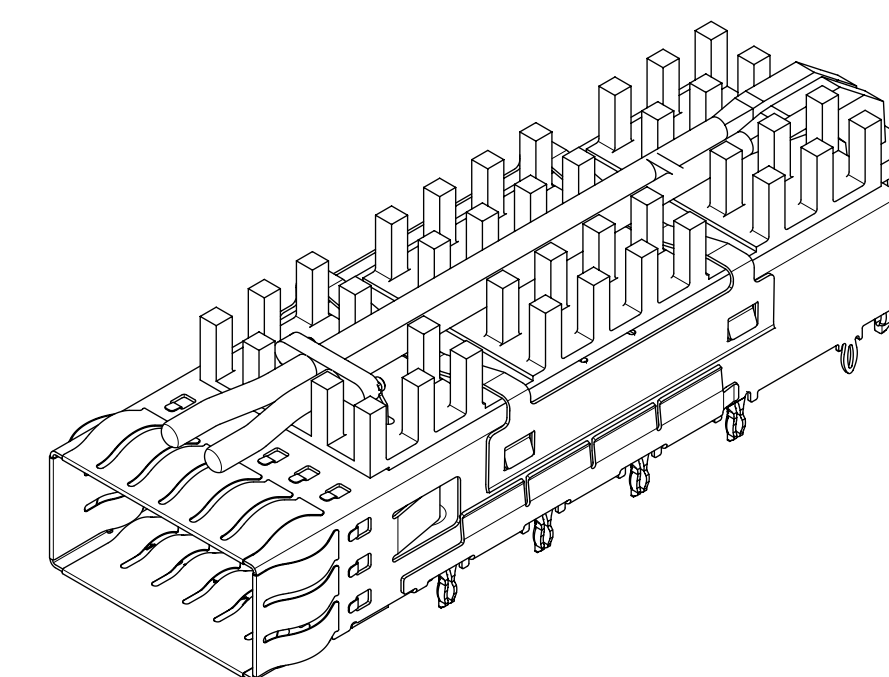
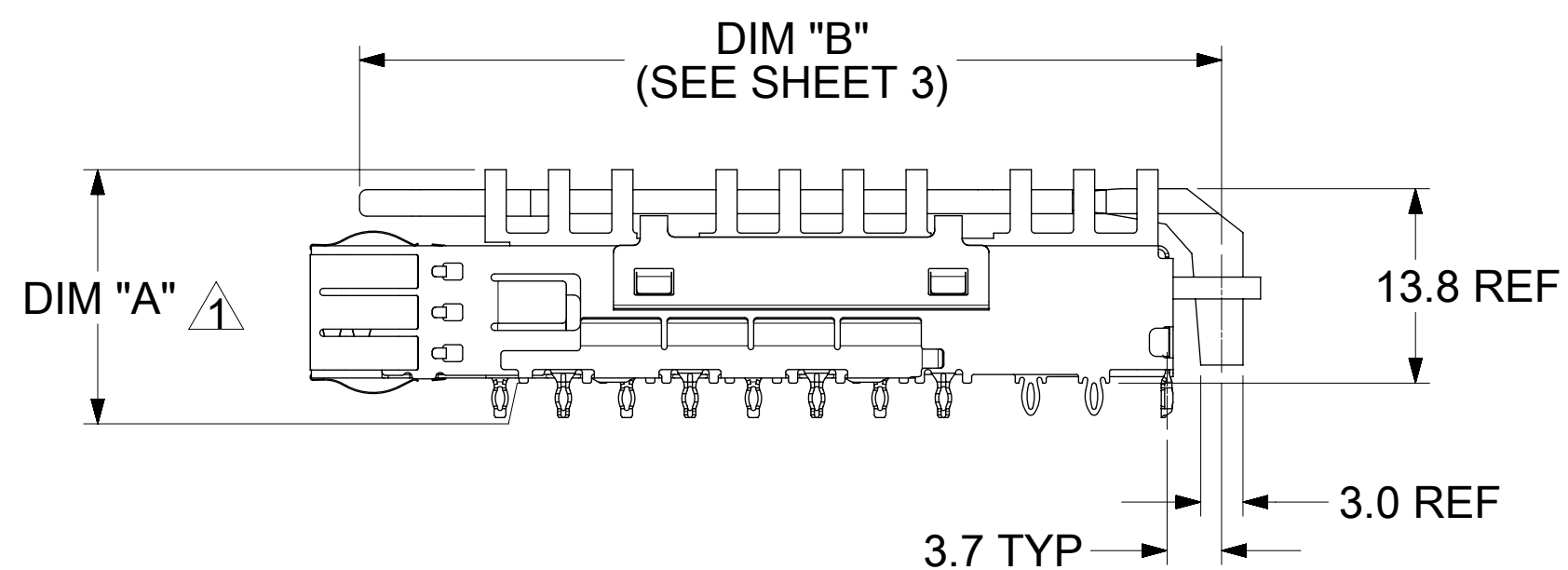
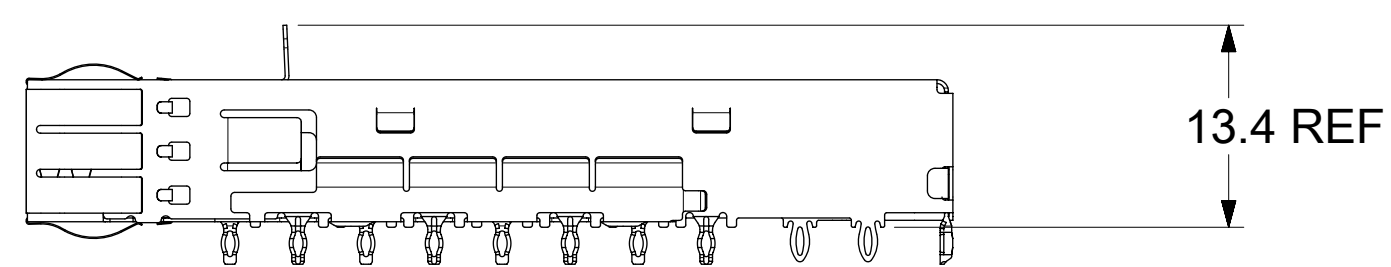
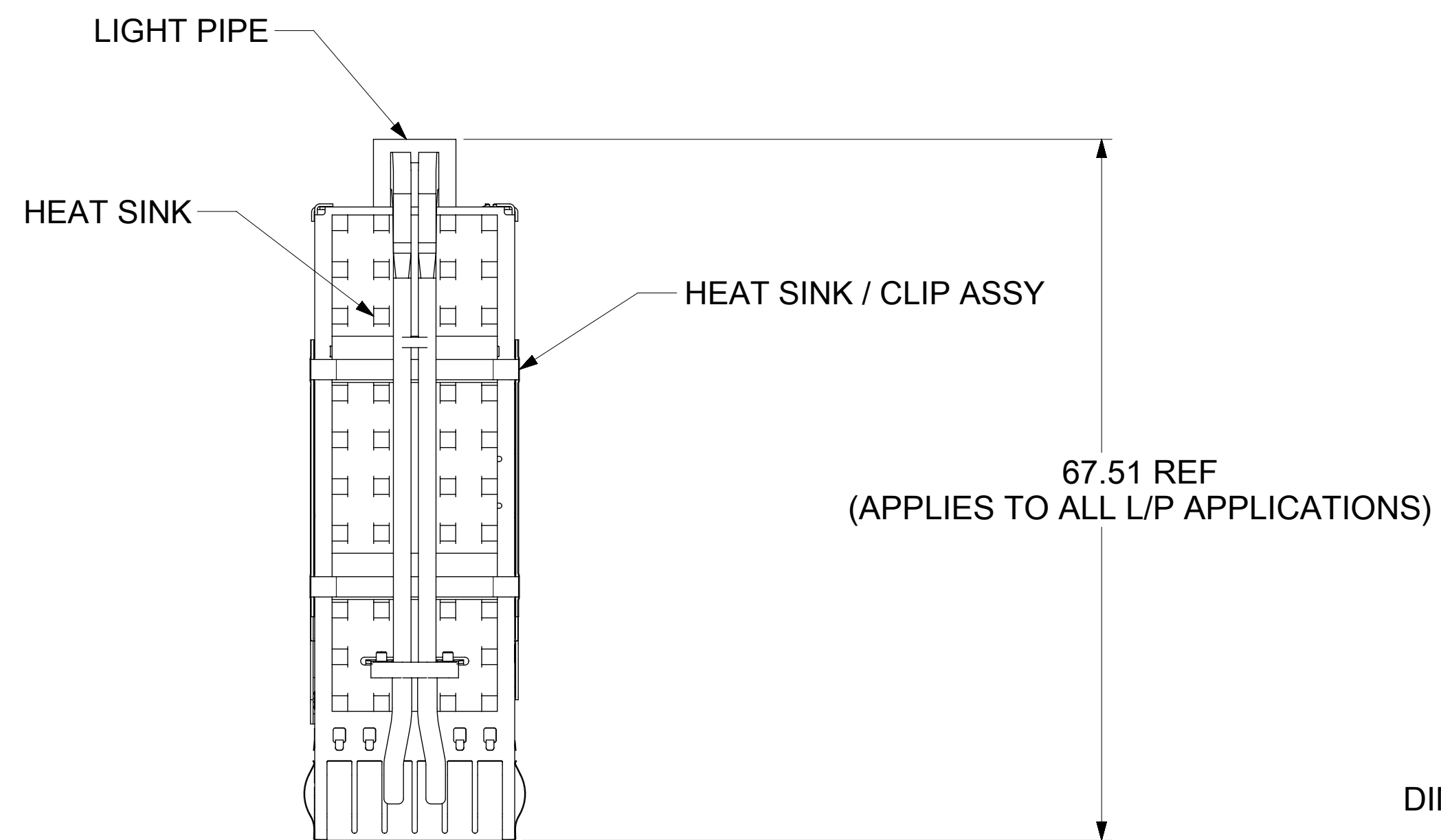

HEATSINK HEIGHT OPTIONS

OVERALL HEAT SINK HEIGHT	DIM "A"
PCI	13.7 REF
SAN	16.0 REF
NET	23.0 REF

HEIGHT OF HEAT SINK WITH MODULE INSERTED. DIMENSION MAY BE LESS DUE TO MODULE AND HEAT SINK VARIATIONS

REAR LEG OPTIONS

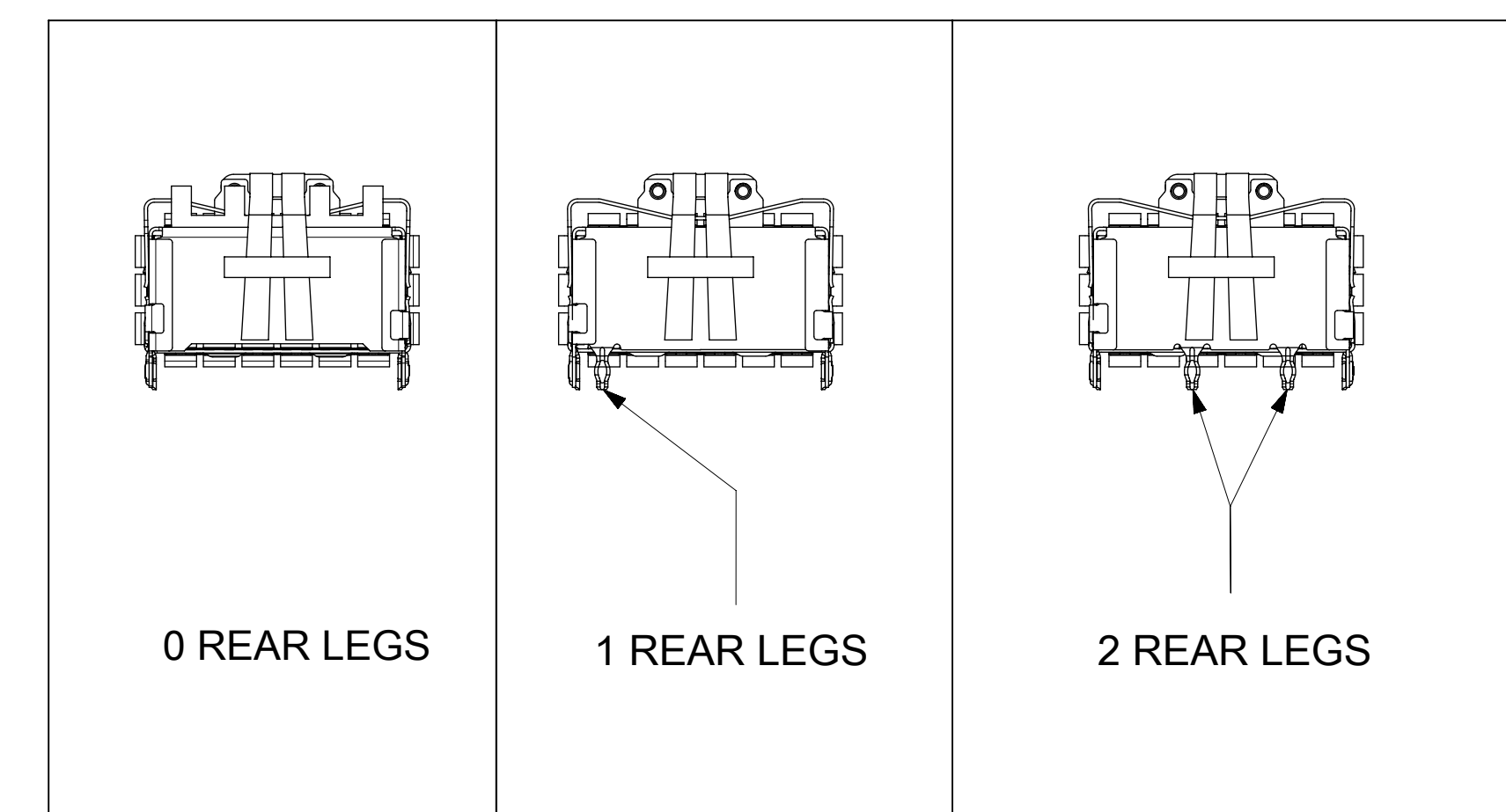

HEATSINK AND LIGHT PIPE COMBINATIONS

HEAT SINK USED WITHOUT LIGHTPIPE

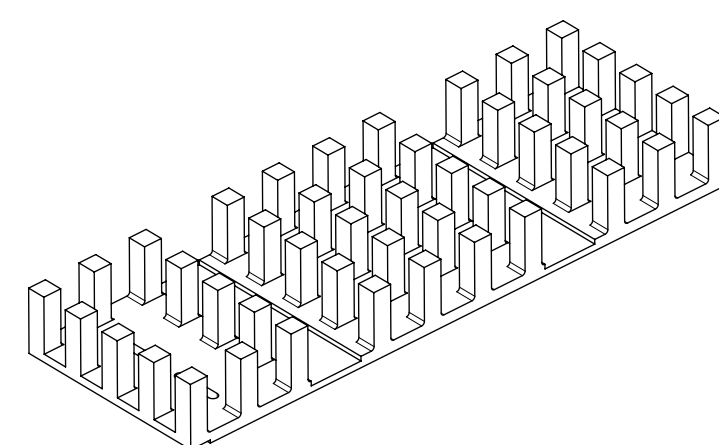

SINGLE / DUAL LIGHT PIPE

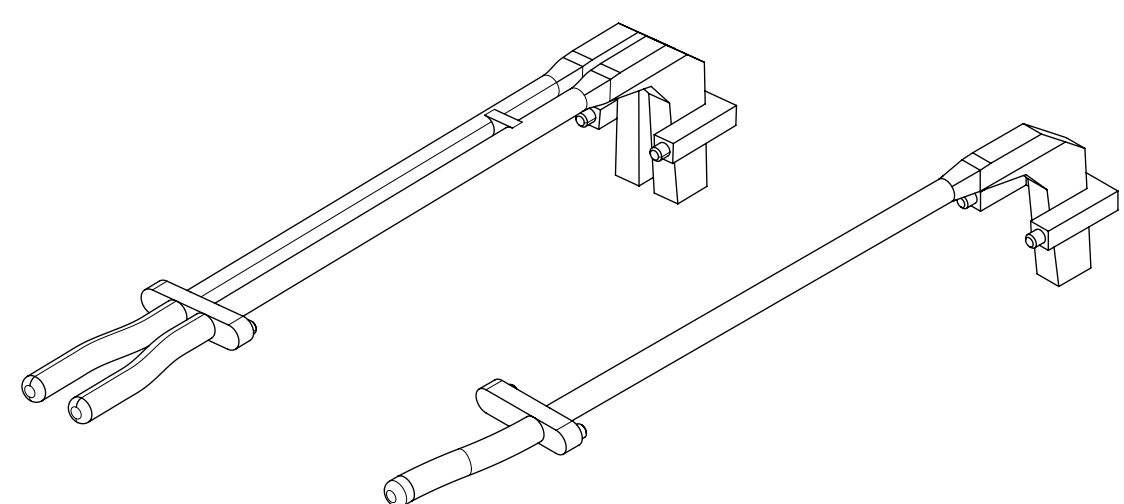

HEATSINK

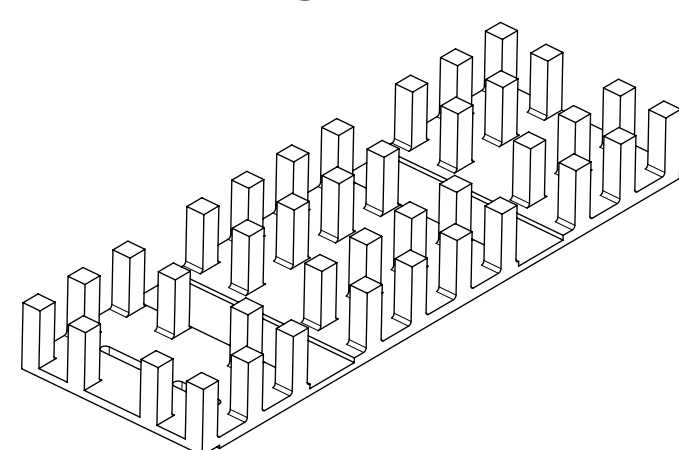

QUAD LIGHT PIPE

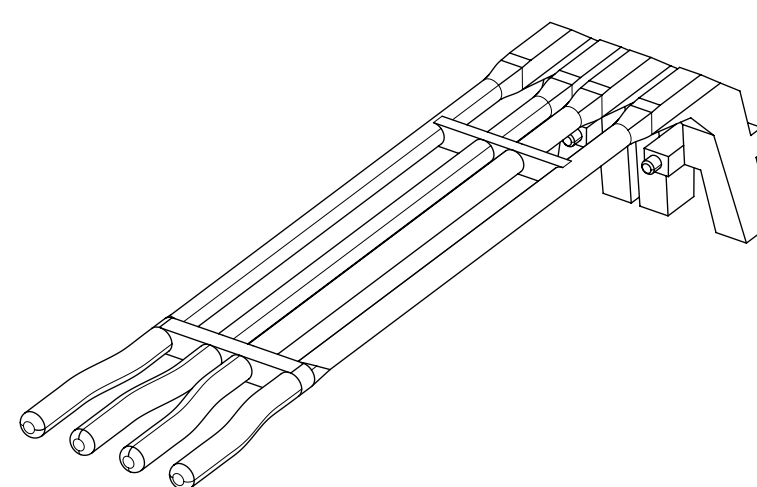

HEATSINK

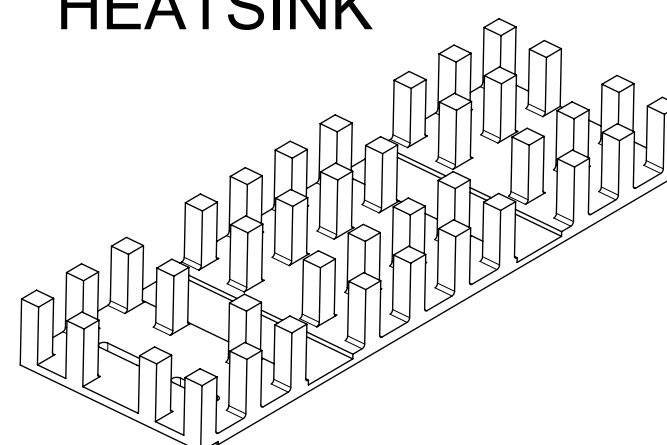

THIS DRAWING CONTAINS INFORMATION THAT IS PROPRIETARY TO MOLEX ELECTRONIC TECHNOLOGIES, LLC AND SHOULD NOT BE USED WITHOUT WRITTEN PERMISSION			
DIMENSION UNITS mm	SCALE 2:1	CURRENT REV DESC: SEE REVISION TABLE	
GENERAL TOLERANCES (UNLESS SPECIFIED)		EC NO: 623918	
ANGULAR TOL	± 2.0°	DRWN: VLOKESHA	2019/08/23
4 PLACES	±	CHK'D: JYEN01	2019/09/11
3 PLACES	±	APPR: JCHIANG	2019/09/11
2 PLACES	± 0.13	INITIAL REVISION:	
1 PLACE	± 0.25	DRWN: PGSHETTY	2015/10/21
0 PLACES	±	APPR: RCHEN08	2015/11/16
DRAFT WHERE APPLICABLE MUST REMAIN WITHIN DIMENSIONS	THIRD ANGLE PROJECTION	DRAWING	SERIES
		D-SIZE	100014
MATERIAL NUMBER		CUSTOMER	SHEET NUMBER
SEE DRAWING		GENERAL MARKET	2 OF 8

molex

ZQSFP+ 1X1 CAGE ASSY'S (SPRING FINGER) WITH H/S & L/P OPTIONS

PRODUCT CUSTOMER DRAWING

DOCUMENT NUMBER DOC TYPE DOC PART REVISION

1000141200

PSD ASY L1

PART NUMBER SELECTION

NO HEATSINKS
WITH LIGHT PIPES
CLOSED TOP

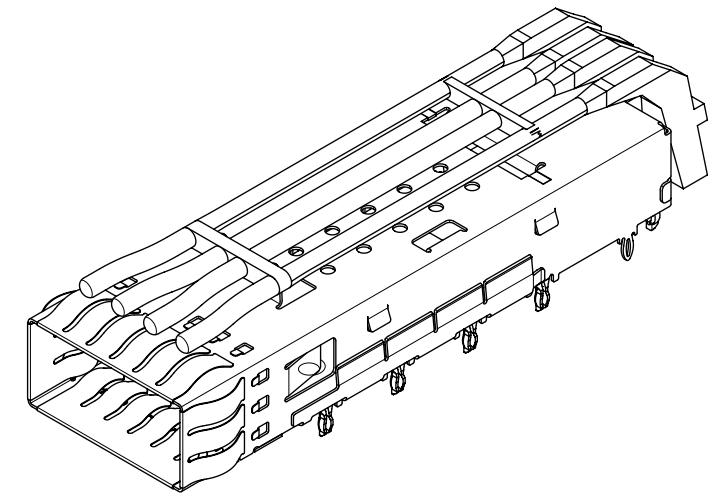

MOLEX P/N	LIGHT PIPES	#OF REAR LEGS PER PORT	DIM "B"
1000141231	SINGLE	0	61.07 REF
1000141232	SINGLE	1	61.07 REF
1000141233	DUAL	0	61.07 REF
1000141234	DUAL	1	61.07 REF
1000141235	QUAD	0	61.07 REF
1000141236	QUAD	1	61.07 REF

NO HEATSINKS
NO LIGHT PIPES
CLOSED TOP

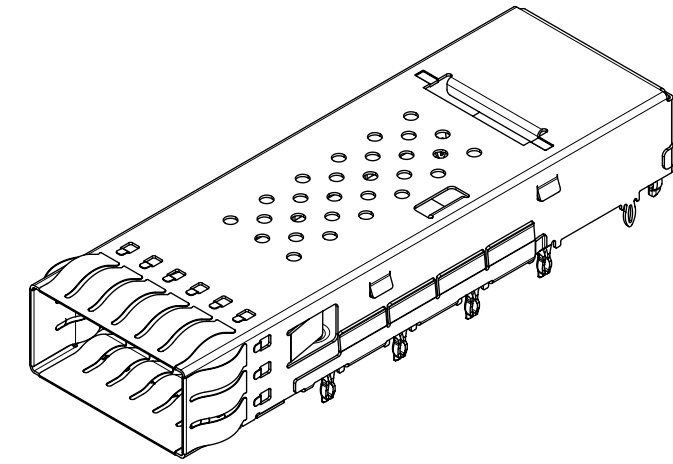

MOLEX P/N W/ SPRING FINGERS	#OF REAR LEGS PER PORT
1000141240	0
1000141242	1

NO HEATSINKS
NO LIGHT PIPES
OPEN TOP

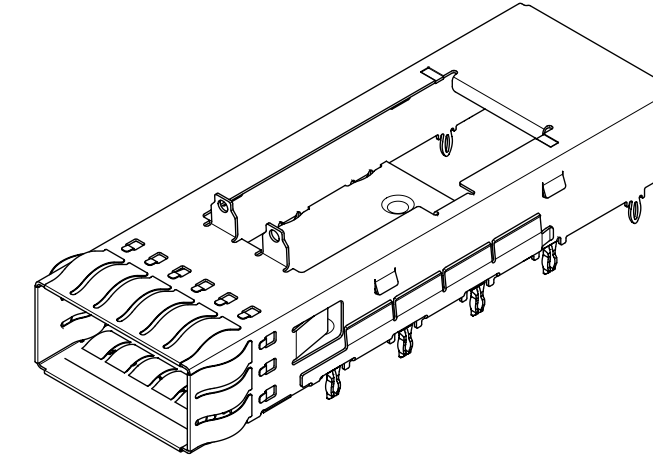

MOLEX P/N W/ SPRING FINGERS	#OF REAR LEGS PER PORT	LP TAB FEATURE
1000141250	0	YES
1000141252	1	YES
1000141253	2	YES
1000141256	2	NO

WITH HEATSINKS
NO LIGHT PIPES

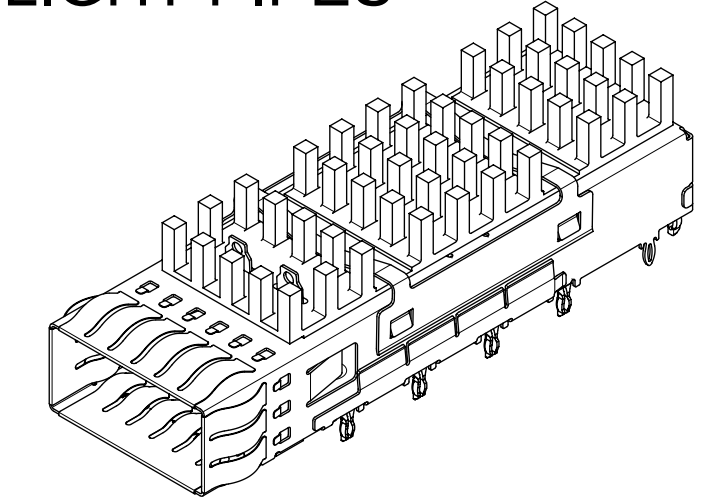

MOLEX P/N	HEATSINKS	#OF REAR LEGS PER PORT
1000141340	PCI	0
1000141341	SAN	0
1000141342	NET	0
1000141343	PCI	1
1000141344	SAN	1
1000141345	NET	1
1000141346	PCI	2
1000141348	NET	2
1000141903	CUSTOM DIM A=20 REF	2

WITH HEATSINKS AND LIGHT PIPES

MOLEX P/N	LIGHTPIPES	HEATSINKS	#OF REAR LEGS PER PORT	DIM "B"
1000141442	SINGLE	NET	0	61.07 REF
1000141443	DUAL	PCI	0	61.07 REF
1000141445	DUAL	NET	0	61.07 REF
1000141447	QUAD	SAN	0	61.07 REF
1000141448	QUAD	NET	0	61.07 REF
1000141540	SINGLE	PCI	1	61.07 REF
1000141541	SINGLE	SAN	1	61.07 REF
1000141542	SINGLE	NET	1	61.07 REF
1000141543	DUAL	PCI	1	61.07 REF
1000141544	DUAL	SAN	1	61.07 REF
1000141545	DUAL	NET	1	61.07 REF
1000141546	QUAD	PCI	1	61.07 REF
1000141547	QUAD	SAN	1	61.07 REF
1000141548	QUAD	NET	1	61.07 REF
1000141640	SINGLE	PCI	2	61.07 REF
1000141641	SINGLE	SAN	2	61.07 REF
1000141642	SINGLE	NET	2	61.07 REF
1000141643	DUAL	PCI	2	61.07 REF
1000141644	DUAL	SAN	2	61.07 REF
1000141645	DUAL	NET	2	61.07 REF
1000141646	QUAD	PCI	2	61.07 REF
1000141647	QUAD	SAN	2	61.07 REF
1000141648	QUAD	NET	2	61.07 REF
1000141744	DUAL	SAN	2	59.47 REF

SINGLE LIGHT PIPE

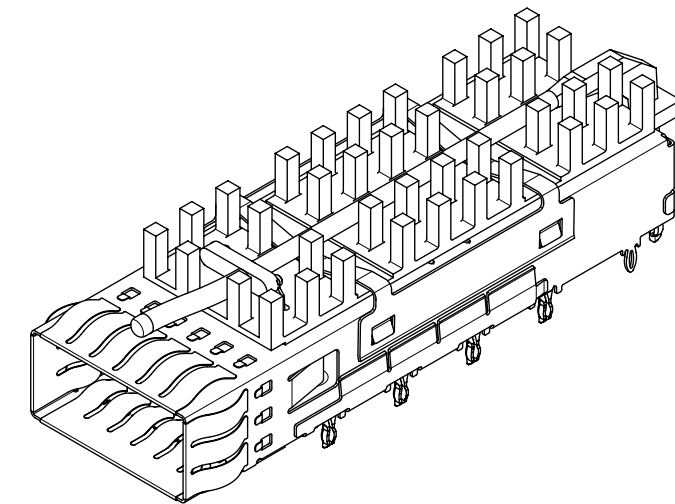

DUAL LIGHT PIPE

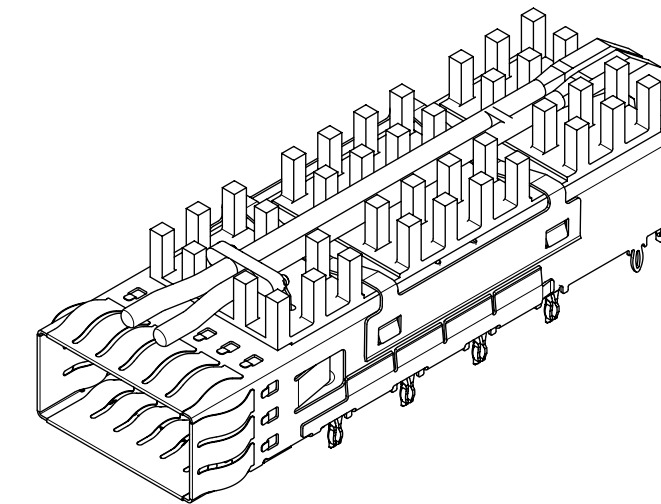

QUAD LIGHT PIPE

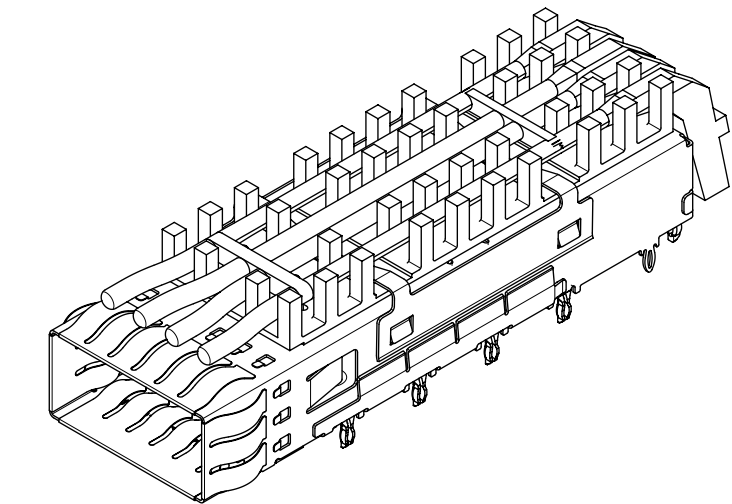

THIS DRAWING CONTAINS INFORMATION THAT IS PROPRIETARY TO MOLEX ELECTRONIC TECHNOLOGIES, LLC AND SHOULD NOT BE USED WITHOUT WRITTEN PERMISSION

DIMENSION UNITS	SCALE	CURRENT REV DESC: SEE REVISION TABLE	
mm	1.5:1		
GENERAL TOLERANCES (UNLESS SPECIFIED)		EC NO: 623918	
ANGULAR TOL	± 2.0°	DRWN: VLOKESHA	2019/08/23
4 PLACES	±	CHK'D: JYEN01	2019/09/11
3 PLACES	±	APPR: JCHIANG	2019/09/11
2 PLACES	± 0.13	INITIAL REVISION:	
1 PLACE	± 0.25	DRWN: PGSHETTY	2015/10/21
0 PLACES	±	APPR: RCHEN08	2015/11/16
DRAFT WHERE APPLICABLE MUST REMAIN WITHIN DIMENSIONS		THIRD ANGLE PROJECTION	DRAWING SERIES
			D-SIZE 100014
		MATERIAL NUMBER	CUSTOMER
		SEE DRAWING	GENERAL MARKET
		DOCUMENT NUMBER	DOC TYPE DOC PART REVISION
		1000141200	PSD ASY L1
		SHEET NUMBER	
		3 OF 8	

molex

ZQSFP+ 1X1 CAGE
ASSY'S (SPRING FINGER) WITH H/S & L/P OPTIONS

PRODUCT CUSTOMER DRAWING

DOCUMENT NUMBER: 1000141200
DOC TYPE: PSD
DOC PART: ASY
REVISION: L1

MATERIAL NUMBER: SEE DRAWING
CUSTOMER: GENERAL MARKET
SHEET NUMBER: 3 OF 8

PCB LAYOUT FOR SINGLE SIDED MOUNTING

NO REAR LEGS

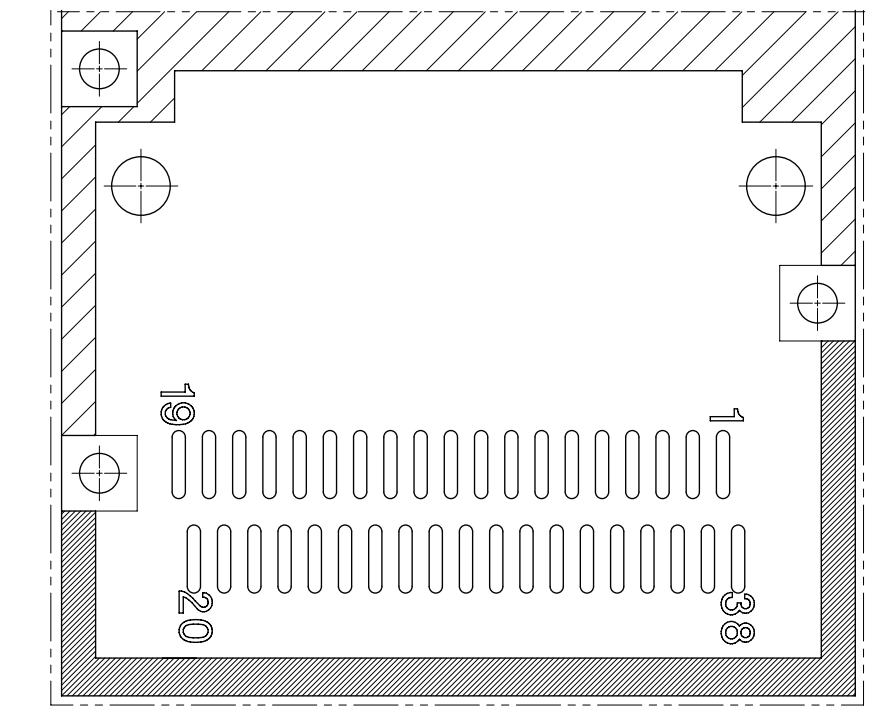

PARTIAL 1
SCALE 5:1

1 REAR LEG

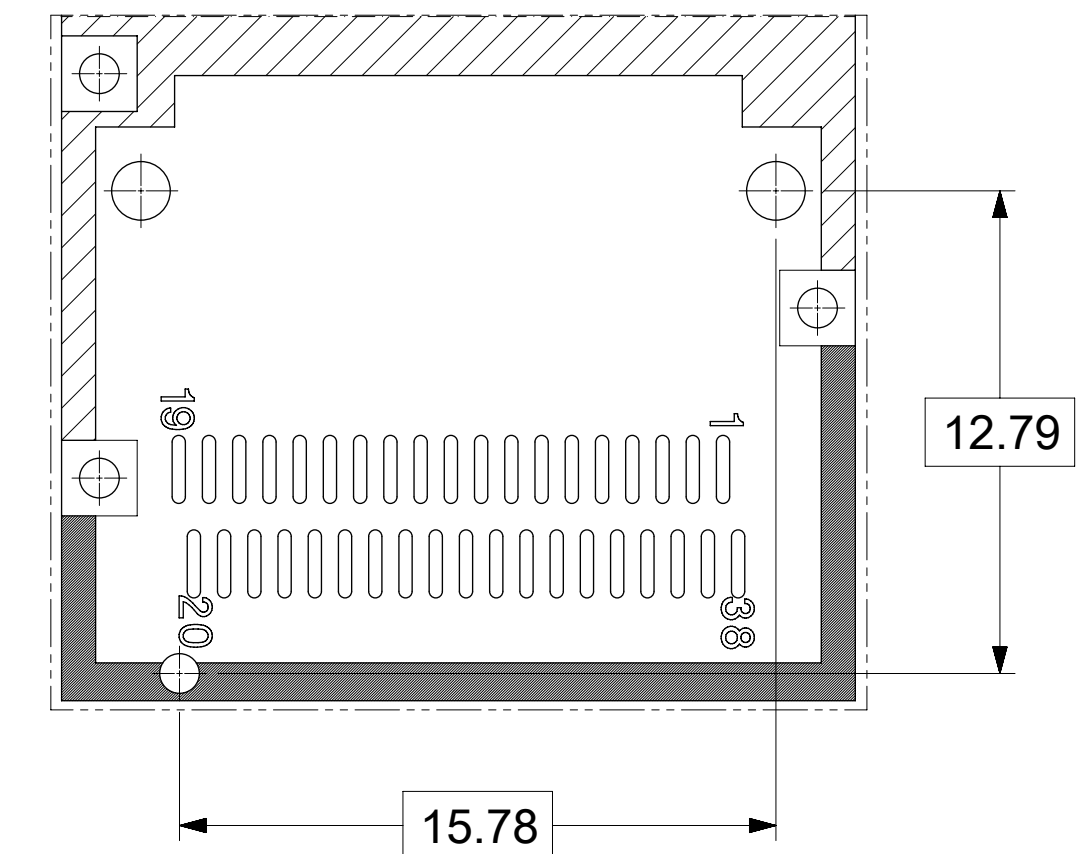

PARTIAL 2
SCALE 5:1

2 REAR LEGS

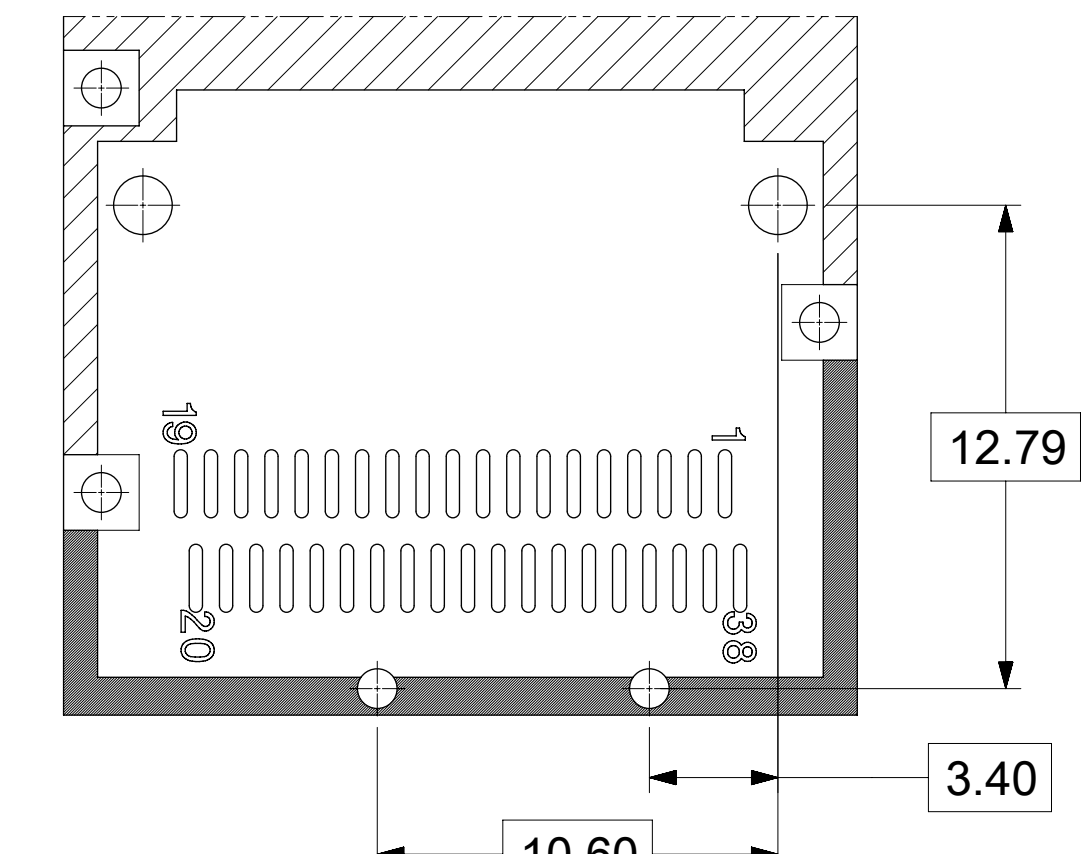

PARTIAL 3
SCALE 5:1

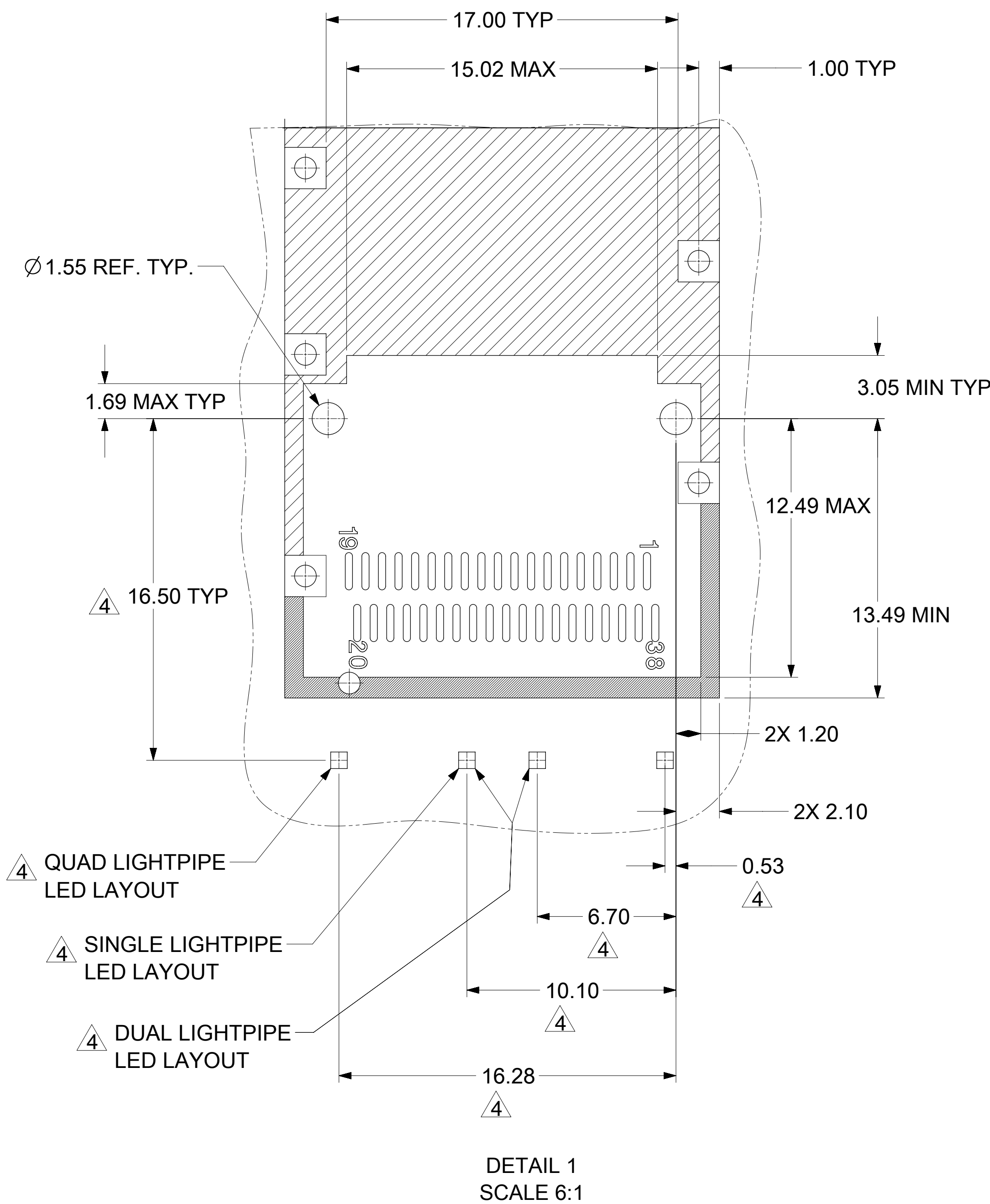

DETAIL 1
SCALE 6:1

HATCHED AREA DENOTES
COMPONENT AND TRACE KEEP-OUT
(EXCEPT CHASSIS GROUND)

Ø 1.05 ± 0.05 TYP
Ø 0.10 (M) A K L

AREA DENOTES
COMPONENT KEEP-OUT
(TRACES ALLOWED)

DATUM -A- IS THE TOP
SURFACE OF HOST BOARD

CROSS HATCHED AREA DENOTES
WHERE SURFACE TRACES
ARE PERMITTED

SEE DETAIL 1

37.00 MAX

34.60

30.10

25.60

21.10

16.60

12.10

7.60

3.10

3.10

7.60

12.79

0.00

0.00

HOLE OF
ADJACENT CAGE

17.90

16.80

1.10

4.50

NOTES:

1. PADS AND VIAS GO TO CHASSIS GROUND. (RECOMMENDED PADS TO BE 2.00mm SQUARE.)
2. RECOMMENDED THRU HOLE PLATING INCLUDES HASL, OSP, OR IMMERSION (GOLD, SILVER, OR TIN).
3. CONNECTOR PAD LAYOUT PER SFF-8663 WILL ACCOMMODATE MOLEX CONNECTOR SERIES 170432.
4. NOTED DIMENSIONS ONLY APPLY TO CAGE ASSEMBLIES WITH LIGHT PIPES.

THIS DRAWING CONTAINS INFORMATION THAT IS PROPRIETARY TO MOLEX ELECTRONIC TECHNOLOGIES, LLC AND SHOULD NOT BE USED WITHOUT WRITTEN PERMISSION

DIMENSION UNITS: mm
SCALE: 3.5:1

CURRENT REV DESC: SEE REVISION TABLE

GENERAL TOLERANCES (UNLESS SPECIFIED)	
ANGULAR TOL	± 2.0°
4 PLACES	±
3 PLACES	±
2 PLACES	± 0.13
1 PLACE	± 0.25
0 PLACES	±
DRAFT WHERE APPLICABLE MUST REMAIN WITHIN DIMENSIONS	

EC NO:	623918	2019/08/23
DRWN:	VLOKESHA	2019/09/11
CHK'D:	JYEN01	2019/09/11
APPR:	JCHIANG	2019/09/11
INITIAL REVISION:		
DRWN:	PGSHETTY	2015/10/21
APPR:	RCHEN08	2015/11/16

molex

ZQSFP+ 1X1 CAGE
ASSY'S (SPRING FINGER) WITH H/S & L/P OPTIONS

PRODUCT CUSTOMER DRAWING

DOCUMENT NUMBER	DOC TYPE	DOC PART	REVISION
1000141200	PSD	ASY	L1

DRAWING	SERIES	MATERIAL NUMBER	CUSTOMER	SHEET NUMBER
D-SIZE	100014	SEE DRAWING	GENERAL MARKET	4 OF 8

PCB LAYOUT FOR BELLY TO BELLY MOUNTING

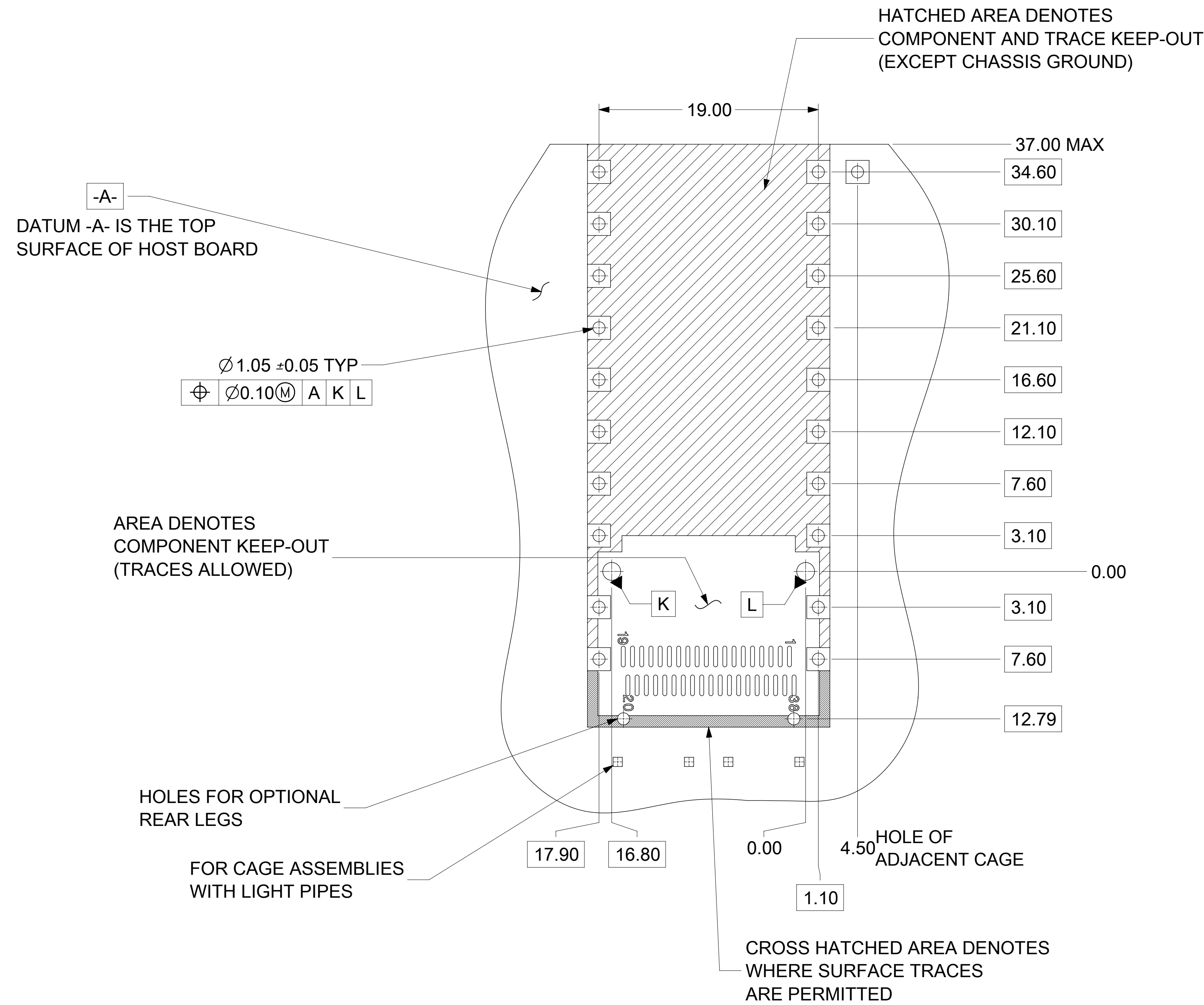

NOTE:
SEE SHEET 4 FOR
HOST CONNECTOR DETAIL
AND LED LOCATION DETAILS

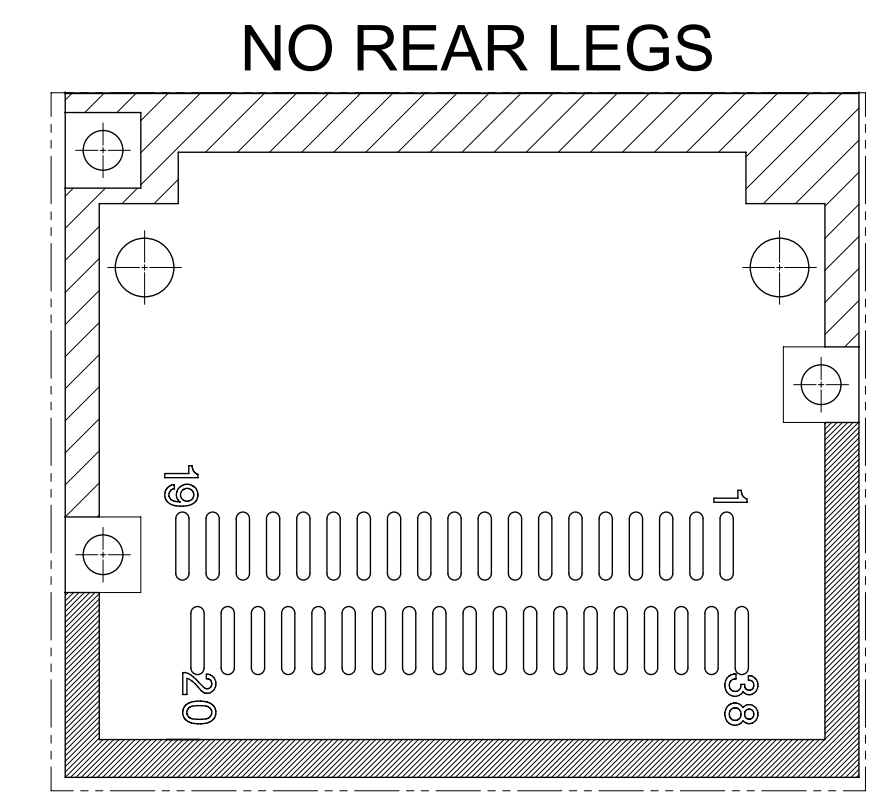

PARTIAL 1
SCALE 5:1

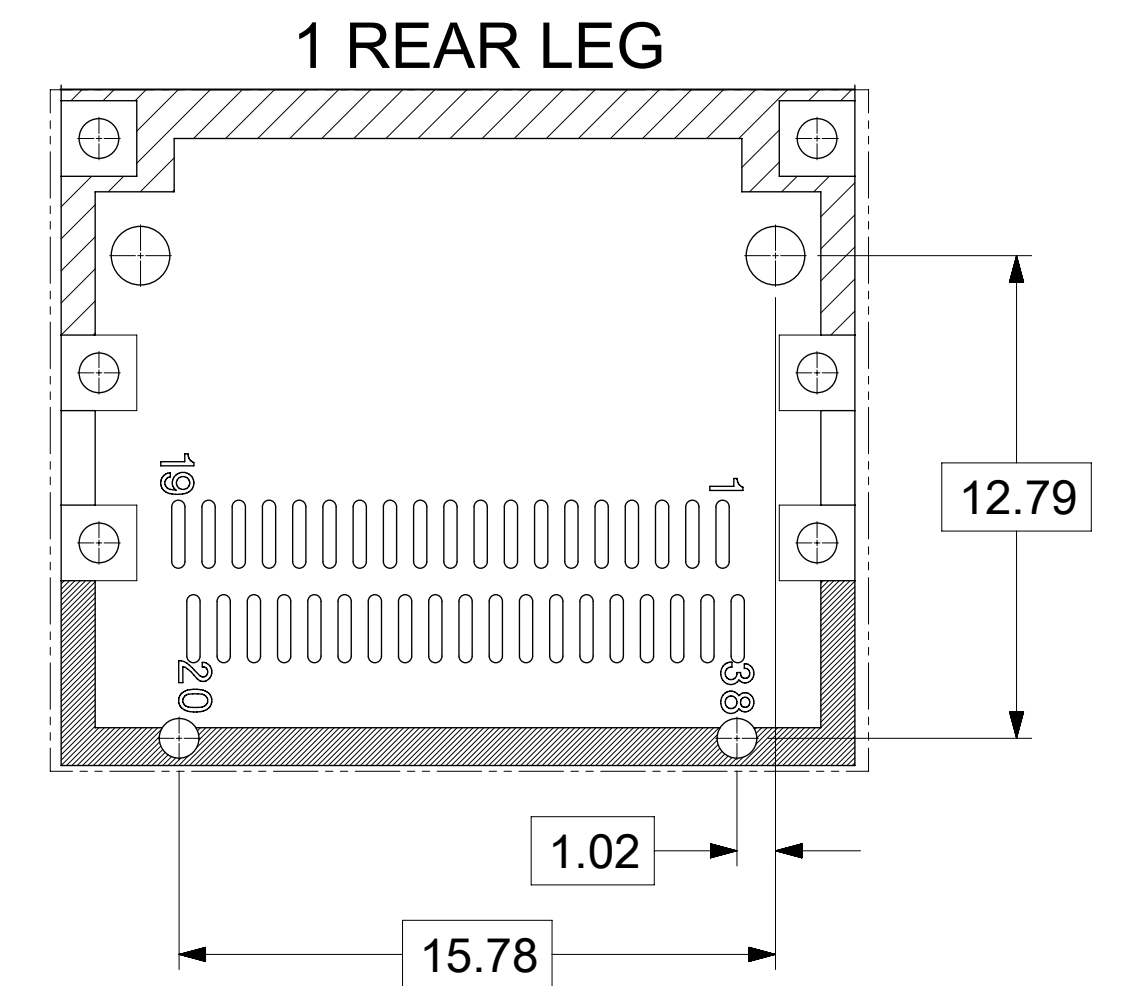

PARTIAL 5
SCALE 5:1

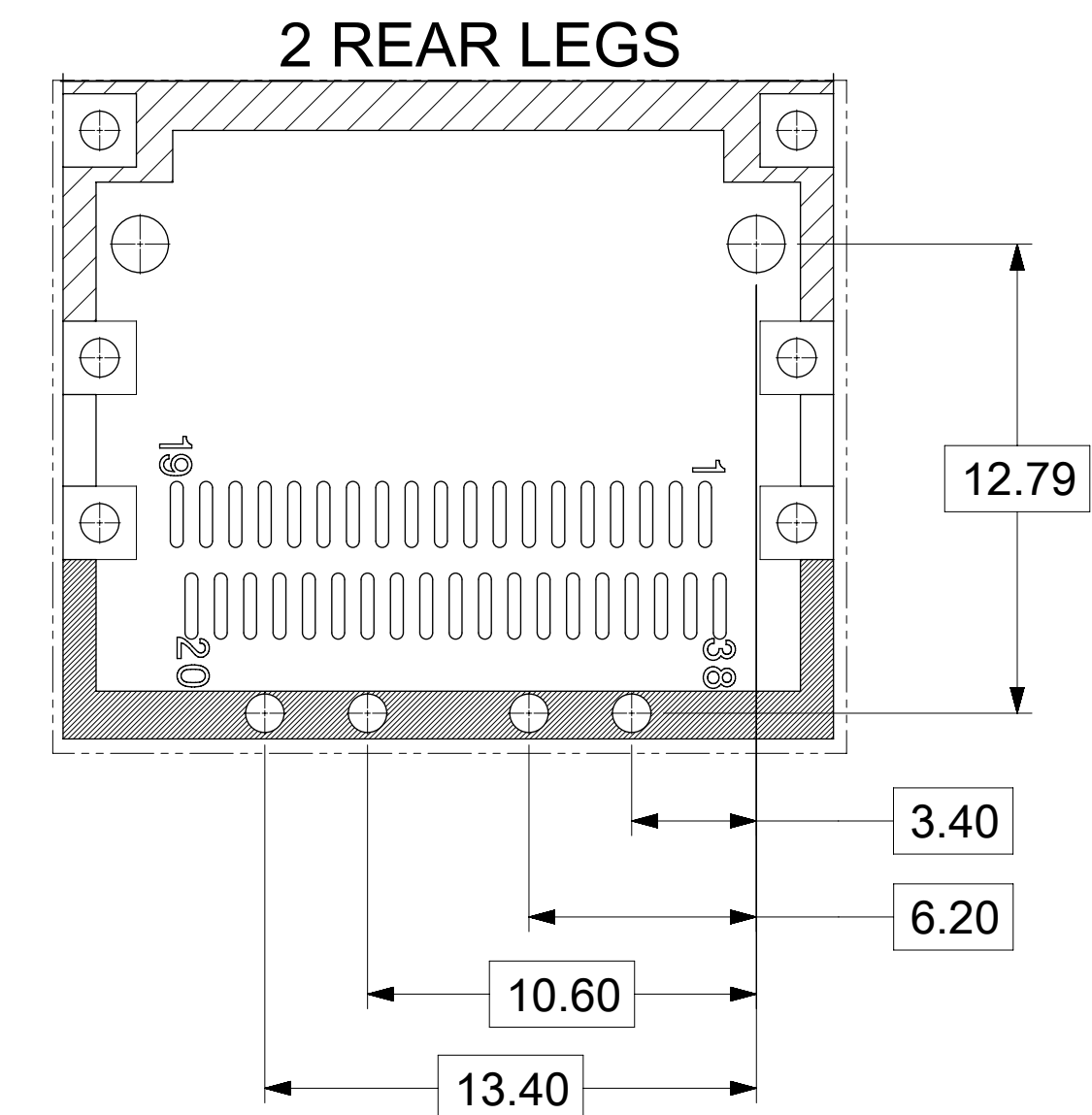

PARTIAL 6
SCALE 5:1

- NOTES:
1. PADS AND VIAS GO TO CHASSIS GROUND. (RECOMMENDED PADS TO BE 2.00mm SQUARE.)
 2. RECOMMENDED THRU HOLE PLATING INCLUDES HASL, OSP, OR IMMERSION (GOLD, SILVER, OR TIN).
 3. CONNECTOR PAD LAYOUT PER SFF-8663 WILL ACCOMODATE MOLEX CONNECTOR SERIES 170432.

THIS DRAWING CONTAINS INFORMATION THAT IS PROPRIETARY TO MOLEX ELECTRONIC TECHNOLOGIES, LLC AND SHOULD NOT BE USED WITHOUT WRITTEN PERMISSION

DIMENSION UNITS mm	SCALE 4:1	CURRENT REV DESC: SEE REVISION TABLE	
GENERAL TOLERANCES (UNLESS SPECIFIED)		EC NO: 623918	
ANGULAR TOL	± 2.0°	DRWN: VLOKESHA	2019/08/23
4 PLACES	±	CHK'D: JYEN01	2019/09/11
3 PLACES	±	APPR: JCHIANG	2019/09/11
2 PLACES	± 0.13	INITIAL REVISION:	
1 PLACE	± 0.25	DRWN: PGSHETTY	2015/10/21
0 PLACES	±	APPR: RCHEN08	2015/11/16
DRAFT WHERE APPLICABLE MUST REMAIN WITHIN DIMENSIONS		THIRD ANGLE PROJECTION	DRAWING
			D-SIZE
		SERIES	MATERIAL NUMBER
		100014	1000141200
		CUSTOMER	REVISION
		GENERAL MARKET	L1
DOCUMENT STATUS	P1	RELEASE DATE	2019/09/11 08:13:14
		SHEET NUMBER	5 OF 8

molex

ZQSFP+ 1X1 CAGE
ASSY'S (SPRING FINGER) WITH H/S & L/P OPTIONS

PRODUCT CUSTOMER DRAWING

DOCUMENT NUMBER DOC TYPE DOC PART REVISION

1000141200 PSD ASY L1

SEE DRAWING GENERAL MARKET

5 OF 8

**BEZEL AND BOARD POSITION DIMENSIONS
FOR BELLY TO BELLY MOUNTING**

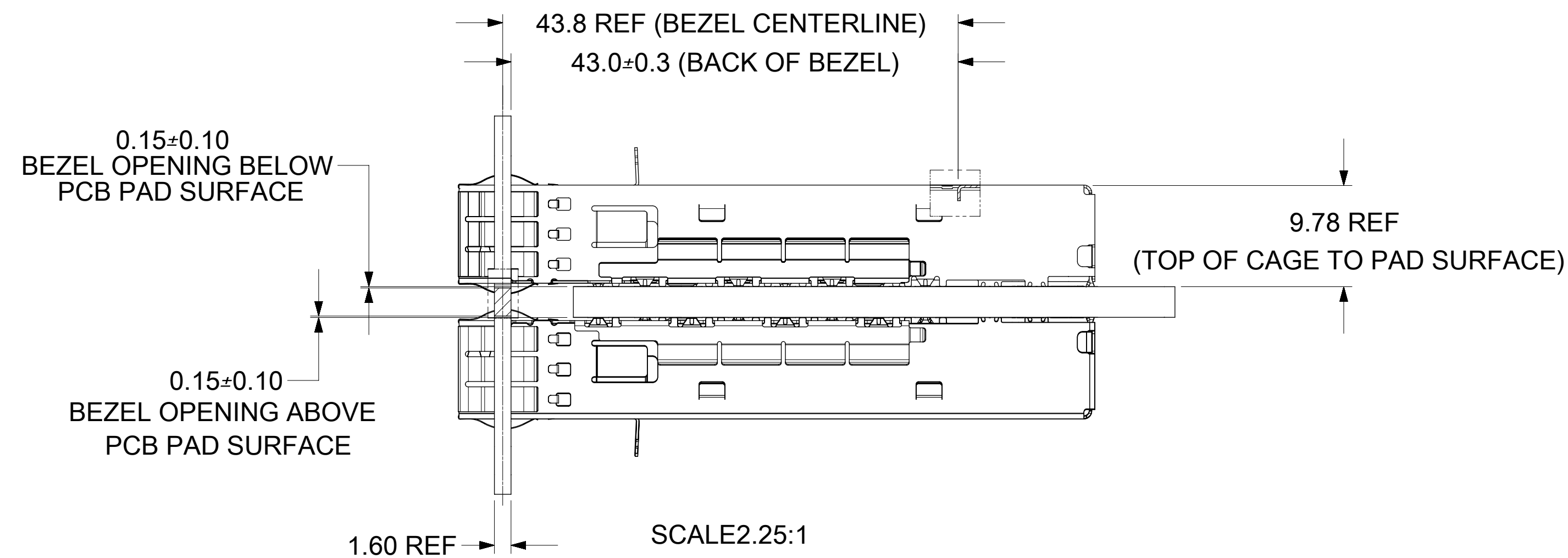

SINGLE LIGHT PIPE ²

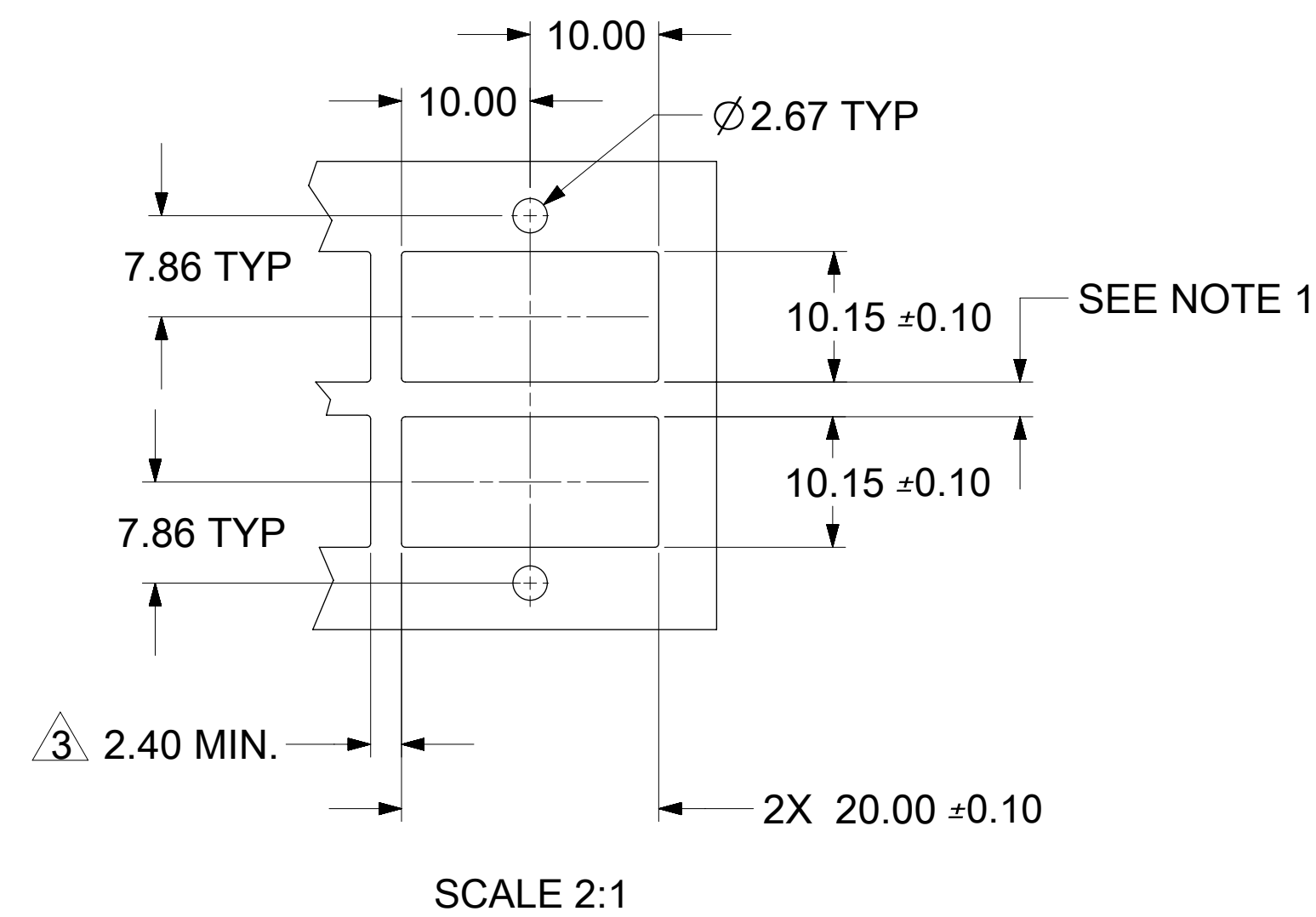

DUAL/QUAD LIGHT PIPE ²

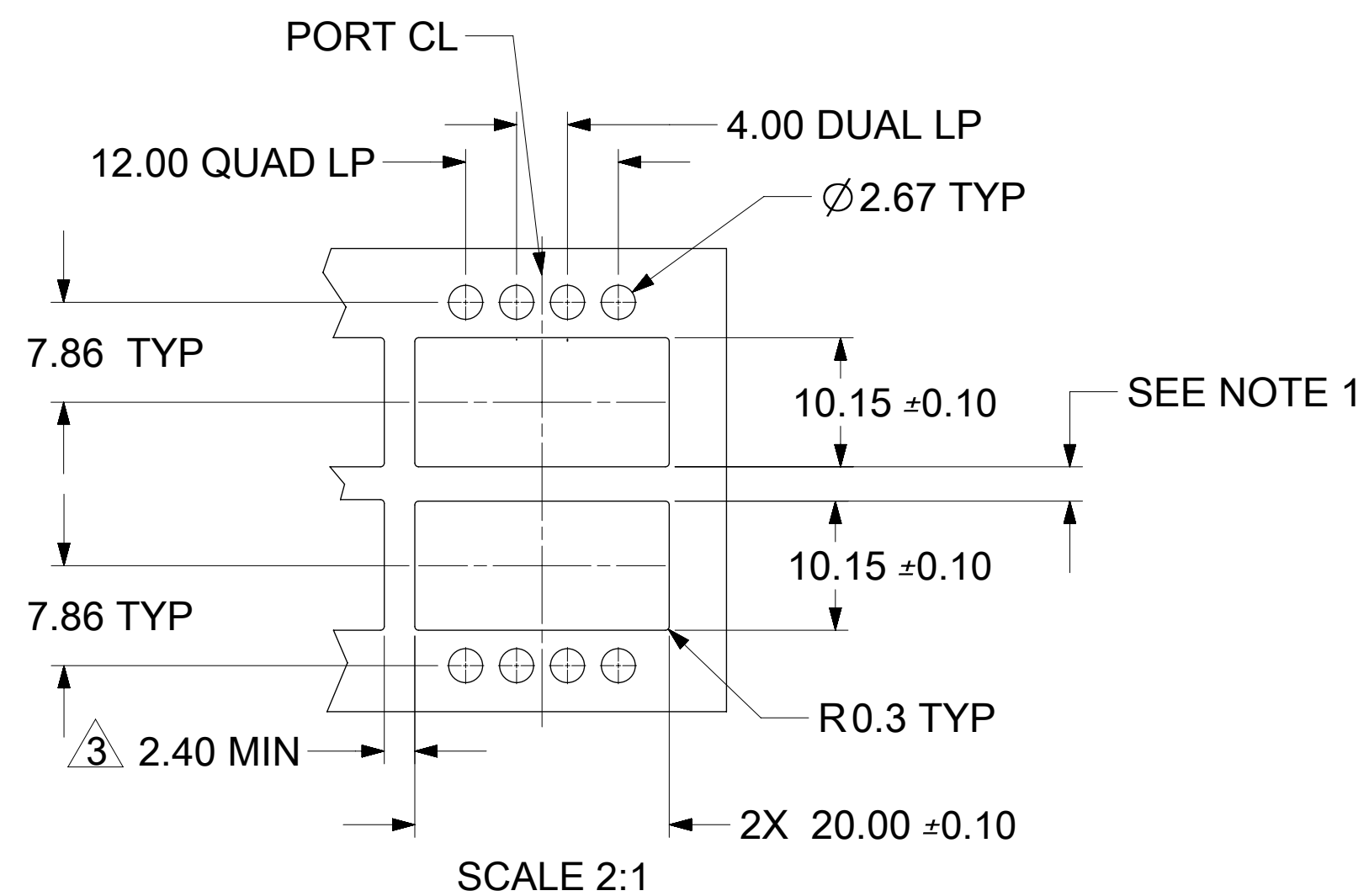

- NOTE:**
1. PCB THICKNESS VARIATION MUST BE CONSIDERED WHEN DETERMINING BEZEL OPENING LOCATION.
 2. NOTED DIMENSIONS ONLY APPLY TO CAGE ASSEMBLIES WITH LIGHT PIPES.
 3. THIS DIMENSION IS FOR REFERENCE ONLY. USER CAN MODIFY UT DEPENDS ON APPLICATION. (THIS DIMENSION VARIES BASED ON DISTANCE OF "HOLE OF ADJACENT CAGE" ON PCB LAYOUT.)

**BEZEL AND BOARD POSITION DIMENSIONS
FOR SINGLE SIDE MOUNTING**

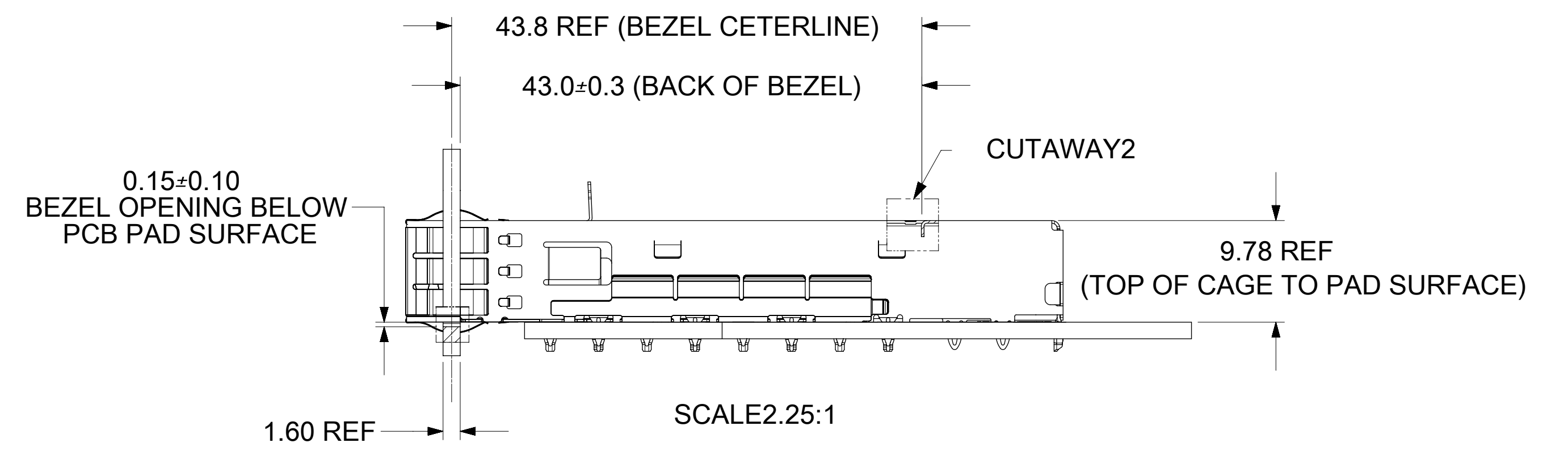

SINGLE LIGHT PIPE ²

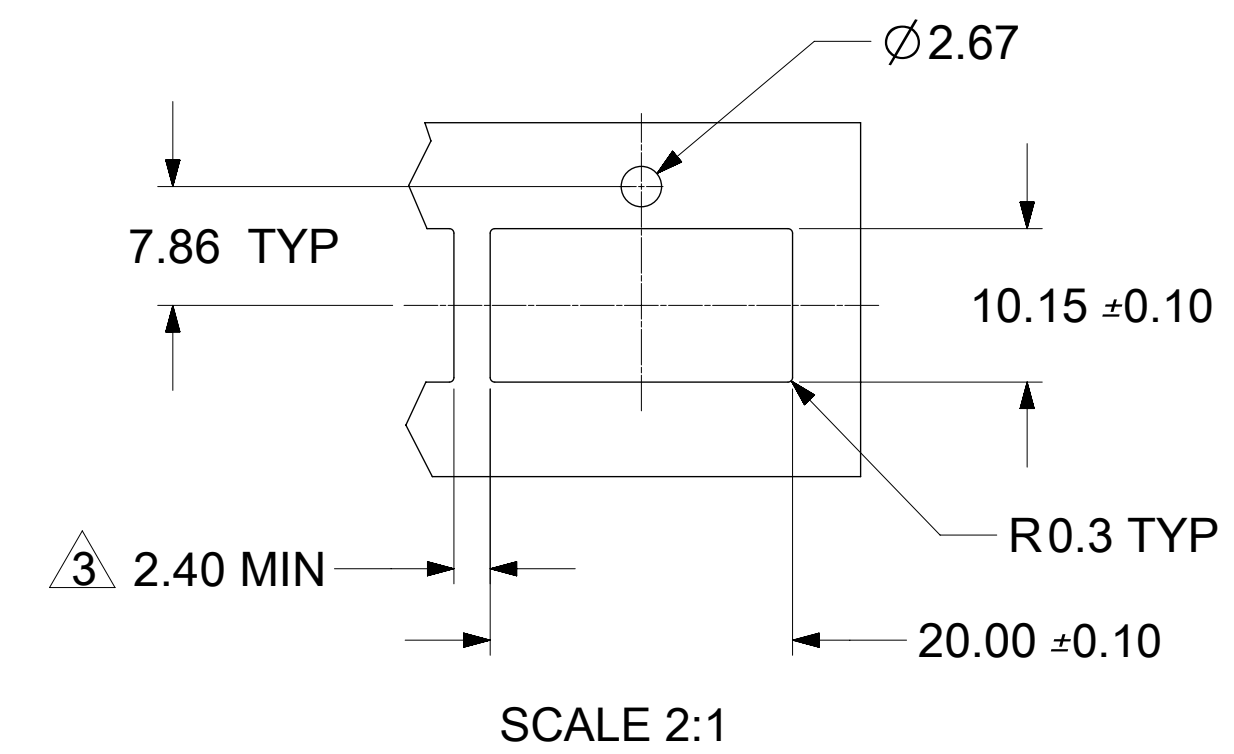

DUAL/QUAD LIGHT PIPE ²

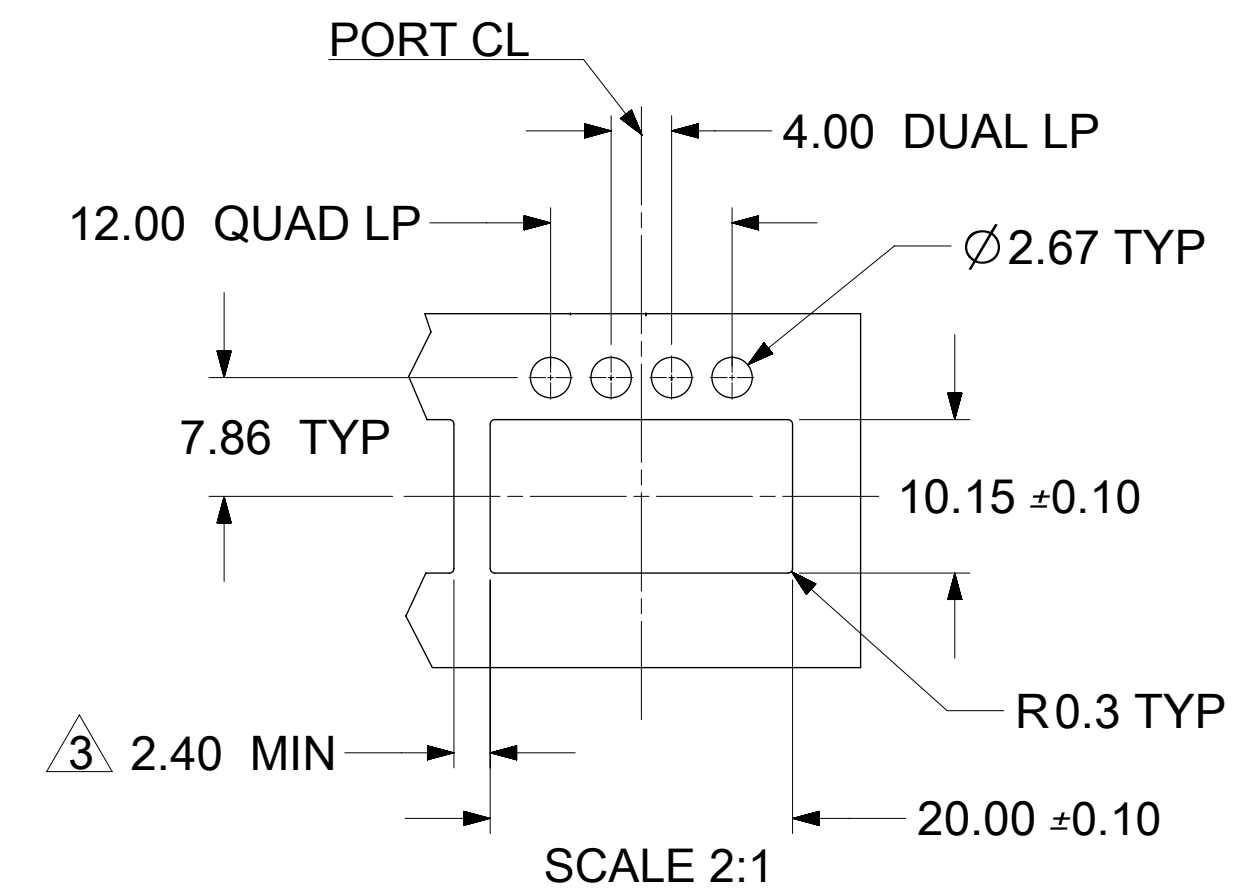

THIS DRAWING CONTAINS INFORMATION THAT IS PROPRIETARY TO MOLEX ELECTRONIC TECHNOLOGIES, LLC AND SHOULD NOT BE USED WITHOUT WRITTEN PERMISSION

DIMENSION UNITS	SCALE	CURRENT REV DESC: SEE REVISION TABLE		molex			
mm	2.5:1						
GENERAL TOLERANCES (UNLESS SPECIFIED)		EC NO: 623918		ZQSFP+ 1X1 CAGE ASSY'S (SPRING FINGER) WITH H/S & L/P OPTIONS			
ANGULAR TOL	± 2.0°	DRWN: VLOKESHA	2019/08/23	PRODUCT CUSTOMER DRAWING			
4 PLACES	±	CHK'D: JYEN01	2019/09/11	DOCUMENT NUMBER			
3 PLACES	±	APPR: JCHIANG	2019/09/11	1000141200			
2 PLACES	± 0.13	INITIAL REVISION:		DOC TYPE	DOC PART	REVISION	
1 PLACE	± 0.25	DRWN: PGSHETTY	2015/10/21	PSD	ASY	L1	
0 PLACES	±	APPR: RCHEN08	2015/11/16	SHEET NUMBER			
DRAFT WHERE APPLICABLE MUST REMAIN WITHIN DIMENSIONS		THIRD ANGLE PROJECTION	DRAWING	SERIES	MATERIAL NUMBER	CUSTOMER	SHEET NUMBER
			D-SIZE	100014	SEE DRAWING	GENERAL MARKET	6 OF 8

REV	DATE	DESCRIPTION
A	2013/03/29	RELEASE
B	2013/06/06	ADDED DIM 12.77 AT G-11 ON SHEET 4
C	2013/11/03	REMOVED GANGED FROM TITLE BLOCK. SHEET 3: ADDED VIEW AND P/N TABLE FOR CLOSED TOP W/LP. SHEET 4/5: EXPANDED ALLOWABLE AREA WHERE SURFACE TRACES ARE PERMITTED.
D	2014/06/26	SHEET 1: ADDED MATERIAL INFORMATION TO NOTES. CHANGED REAR MOST LEG ON BOTH SIDES OF ALL CAGES FROM 3D PRESSFIT TO EYE-OF-THE-NEEDLE PRESSFIT LEG.
E	2014/09/29	ADDED TWO REAR LEG OPTION SHEET 2: CHANGED HEATSINK HEIGHT DIMENSIONS TO REF J14: DIM 67.48 CHANGED TO REF SHEET 4: MOVED DATUMS "K" AND "L" TO CONNECTOR HOLES REMOVED BASIC FROM "0.00" POSITIONS SHEET 5: MOVED DATUMS "K" AND "L" TO CONNECTOR HOLES REMOVED BASIC FROM "0.00" POSITIONS H15: MADE HOLE DIAMETER DIMENSION TYP SHEET 6: EDIT NOTE 1, REMOVED "SIZE" REMOVED NOTE 1 FROM ALL "10.15" DIMENSIONS
F	2015/02/05	SHEET 3: ADDED P/N 1000141744 TO CHART.
G	2015/04/14	SHEET 2: ADDED DIM "B" AT J-10 SHEET 3: ADDED P/N AT A-19 ADDED DIM "B" W/ 61.07 REF TO CHARTS AT G-14 AND I-15 ADDED 59.47 REF AS DIM "B" TO P/N 1000141744 AT A-14 REMOVED NOTE 1 AT A-19 SHEET 4: ADDED DIM 12.79 @G13 REVISED DIM "WAS" 12.77 "NOW" 12.79 @E2 AND @H2 REMOVED SEE NOTE 4 AND ADDED DIMS @K17 REMOVED NOTE 4 AND REVISED NOTE 5 TO NOTE 4 REVISED FRAMED TEXT NUMBER 4 TRIANGLES TO FRAMED TEXT NUMBER 5 @D9, @E8, @E10,@F8, @F10, @G11,AND @H11 SHEET 5: REMOVED NOTE 4 @A20 REMOVED SEE NOTE 4 AND ADDED DIMS @K15 REVISED DIM "WAS" 12.77 "NOW" 12.79 @E2, @I2, AND @F12 SHEET 6: REVISED PORT CL "WAS" (4) "NOW" PORT CL
H	2015/11/02	1. REMASTERED FROM SD-100014-1200_REV 'G' 2. SHEET 3 : G5 : ADDED P/N 1000141903
H1	2016/01/06	CHANGED THE DOCUMENT TYPE FROM RSD TO SD. SHEET1: B19: CHANGED NOTE 4 AND NOTE 5 FROM "DURING INCOMING INSPECTION" TO "DURING FINAL INSPECTION." SHEET6: A19: ADDED NOTE3: THIS DIMENSION IS FOR REFERENCE ONLY. USER CAN MODIFY IT DEPENDS ON APPLICATION. (THIS DIMENSION VARIES BASED ON DISTANCE OF "HOLE OF ADJACENT CAGE" ON PCB LAYOUT.) F16: ADDED 2.40 MIN. B16, F7, C7: CHANGED 2.75 MIN. TO 2.40 MIN.
J	2016/08/16	SHEET 1: D11: ADDED DIM 13.4 REF. SHEET 4: G14: REMOVED DIM 6.60 SHEET 6: J18: ADDED DIM 0.15±0.10 (BEZEL OPENING ABOVE PCB PAD SURFACE)

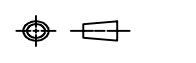
THIS DRAWING CONTAINS INFORMATION THAT IS PROPRIETARY TO MOLEX ELECTRONIC TECHNOLOGIES, LLC AND SHOULD NOT BE USED WITHOUT WRITTEN PERMISSION									
DIMENSION UNITS	SCALE	CURRENT REV DESC: SEE REVISION TABLE							
mm	1:1	 ZQSFP+ 1X1 CAGE ASSY'S (SPRING FINGER) WITH H/S & L/P OPTIONS PRODUCT CUSTOMER DRAWING							
GENERAL TOLERANCES (UNLESS SPECIFIED)									
ANGULAR TOL	± 2.0°								
4 PLACES	±								
3 PLACES	±								
2 PLACES	± 0.13								
1 PLACE	± 0.25	EC NO: 623918	DRWN: VLOKESHA	2019/08/23	DOCUMENT NUMBER 1000141200 DOC TYPE PSD DOC PART ASY REVISION L1				
0 PLACES	±	INITIAL REVISION:	CHK'D: JYEN01	2019/09/11					
DRAFT WHERE APPLICABLE MUST REMAIN WITHIN DIMENSIONS		THIRD ANGLE PROJECTION	DRAWING	SERIES					
			D-SIZE	100014					
		MATERIAL NUMBER	CUSTOMER	SHEET NUMBER					
		SEE DRAWING	GENERAL MARKET	7 OF 8					

REV	DATE	DESCRIPTION
K	2017/09/26	SHEET 3: H6: ADDED LP TAB FEATURE OPTION ON P/N TABLE H9: ADDED NEW P/N 1000141256 IN THE P/N TABLE J9: INDICATED THE LP TAB FEATURE LOCATION
K1	2018/01/30	SHEET 6: J15: CORRECTED PRODUCT VIEW ERROR (COMPONENT APPEARANCE MISSED) J05: CORRECTED PRODUCT VIEW ERROR (COMPONENT APPEARANCE MISSED)
L	2018/05/24	SHEET 4: ADDED PAD TO HOLES & UPDATED VIEWS TO AVOID CONFUSION SHEET 5: ADDED PAD TO HOLES & UPDATED VIEWS TO AVOID CONFUSION
L1	2019/08/23	SHEET 3 : OBSOLETE P/N 1000141347,1000141440,1000141441,1000141444,1000141446. SHEET 1 : H15 : CHANGED MEASURE LINE FROM CAGE TO SPRING FRINGER, DIMENSION FROM 61.27 REF TO 61.29 REF. SHEET 1 : D10 : CORRECTED MEASURE LINE TO CENTER LINE OF FRONT LEG, DIMENSION FROM 13.4 REF TO 13.40 REF.

THIS DRAWING CONTAINS INFORMATION THAT IS PROPRIETARY TO MOLEX ELECTRONIC TECHNOLOGIES, LLC AND SHOULD NOT BE USED WITHOUT WRITTEN PERMISSION									
DIMENSION UNITS	SCALE	CURRENT REV DESC: SEE REVISION TABLE							
mm	1:1	 ZQSFP+ 1X1 CAGE ASSY'S (SPRING FINGER) WITH H/S & L/P OPTIONS PRODUCT CUSTOMER DRAWING							
GENERAL TOLERANCES (UNLESS SPECIFIED)									
ANGULAR TOL	± 2.0°								
4 PLACES	±								
3 PLACES	±								
2 PLACES	± 0.13								
1 PLACE	± 0.25	EC NO: 623918	DRWN: VLOKESHA	2019/08/23	DOCUMENT NUMBER 1000141200 DOC TYPE PSD DOC PART ASY REVISION L1				
0 PLACES	±	CHK'D: JYEN01	2019/09/11						
DRAFT WHERE APPLICABLE MUST REMAIN WITHIN DIMENSIONS		APPR: JCHIANG	2019/09/11						
THIRD ANGLE PROJECTION		INITIAL REVISION:							
DRAWING		DRWN: PGSHETTY	2015/10/21						
SERIES		APPR: RCHEN08	2015/11/16						
D-SIZE		100014		MATERIAL NUMBER		CUSTOMER		SHEET NUMBER	
				SEE DRAWING		GENERAL MARKET		8 OF 8	

DOCUMENT STATUS	P1	RELEASE DATE	2019/09/11	08:13:14
-----------------	----	--------------	------------	----------