

1. MECHANICAL DIMENSIONS :

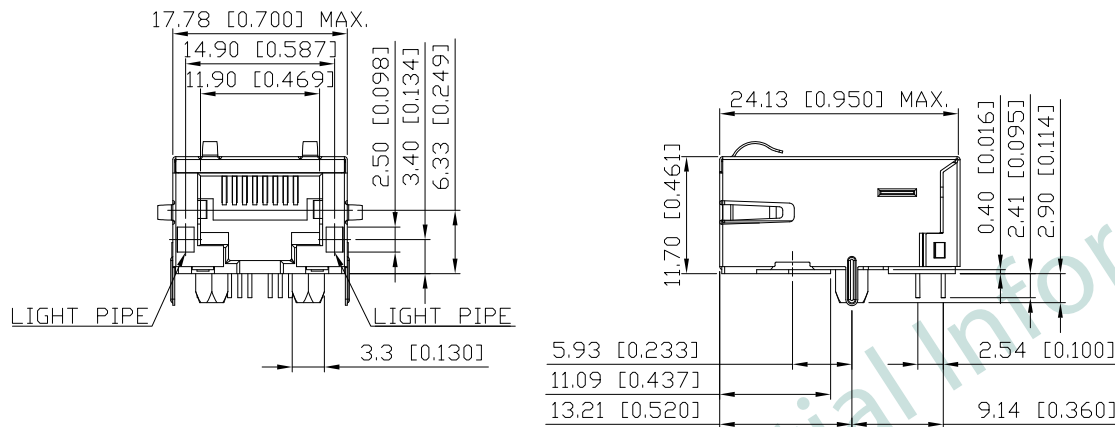

RECOMMENDED PLUG DIMENSION:

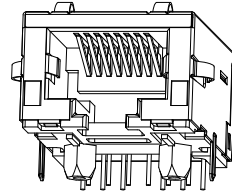
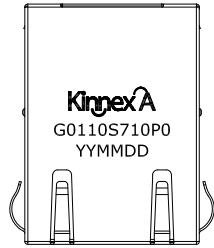
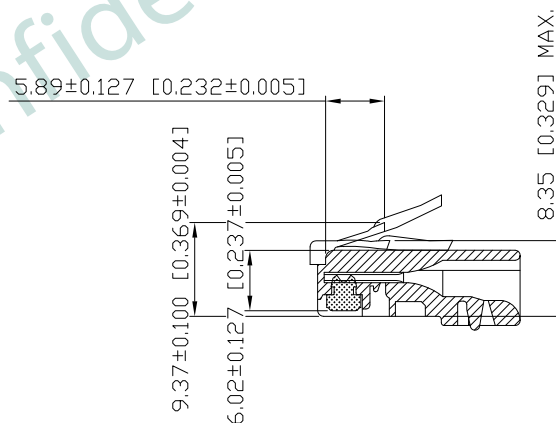

NOTES:

1. MATERIAL:

HOUSING: HIGH THERMOPLASTIC, UL94V-0, BLACK
 CONTACTS: T=0.35mm PHOS-BRONZE PLATED 30u" GOLD AND UNDERPLATE NICKEL ON ALL AREA
 SOLDER PIN: COPPER 0.35X0.45mm, PLATED NICKEL, TIN PLATING IN ALL AREA
 SHIELD: T=0.20mm COPPER ALLOY, PLATED NICKEL
 LIGHT PIPE: POLYCARBONATE

2. OPERATING TEMPERATURE: -40°C~+85°C

3. INSERTION FORCE: 4 POUNDS MAX.
 EXTRACTION FORCE: 4 POUNDS MAX.

4. DURABILITY: 750 MATING CYCLED MIN.

5. CAVITY CONFORMS TO FCC RULES AND REGULATIONS PART 68, SUBPART F.

6. UNSPECIFIED TOLERANCE: .XX ±0.25[0.010]
 .X ±0.30[0.012]

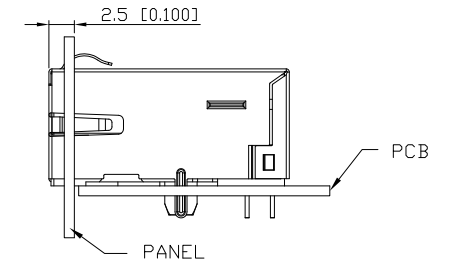
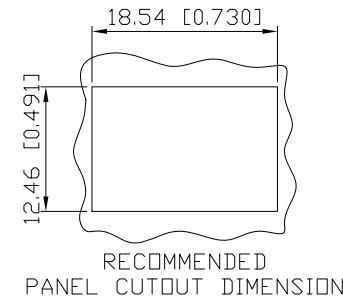

REV.	DATE	DESCRIPTION
03	Jan. 03, '18	1. DELETE BOTTOM VIEW 2. ADD DETAIL VIEW & PIN DEFINITION 3. UPDATE PROFILE OF WAVE SOLDER
02	Apr. 27, '16	1. INK PRINT UPDATE TO LASER PRINT 2. ADD PROFILE OF WAVE SOLDER 3. UPDATE ELECTRICAL CHARACTERISTICS

PART NO		KRG-011-0-S71-0P0		
TITLE	RJ45, W/10G TRANSFORMER, W/LIGHT PIPE, SHIELDED			
REV : 03				
UNIT	DRAWN	CHKD	DATE	SHEET
mm[inch]	CINDY	DANIEL	Jan. 03, '18	1 of 5

2. PCB LAYOUT :

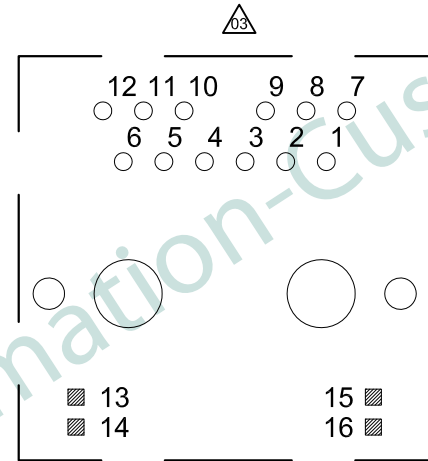
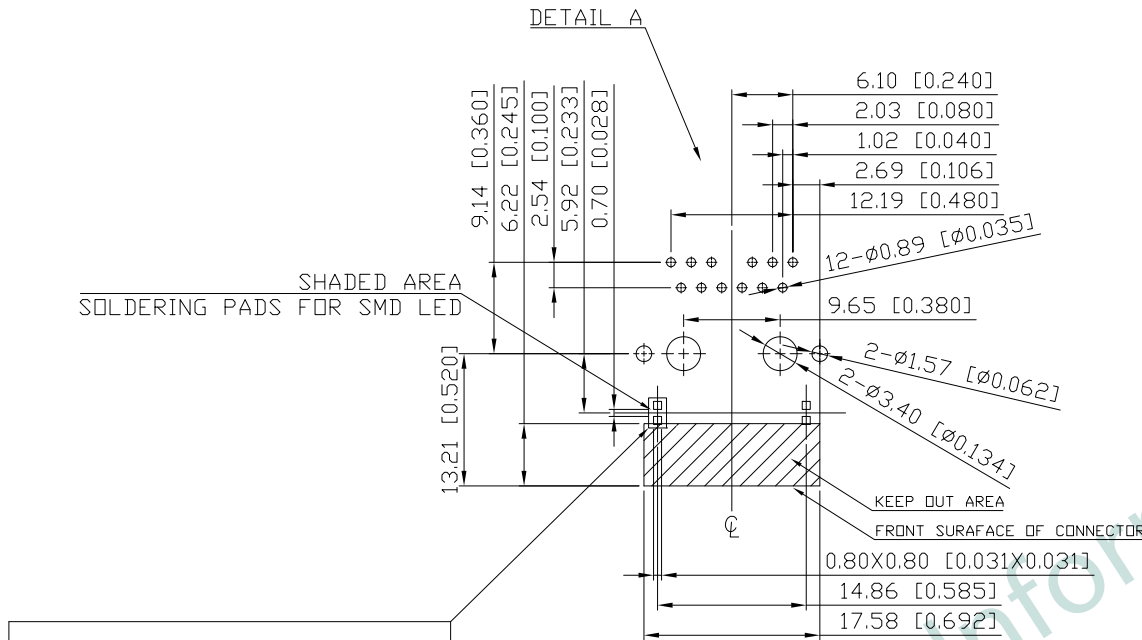

DETAIL A
SCALE: 2:1

P#	DEFINITION
P1	CT
P2	MD(2)-
P3	MD(2)+
P4	MD(1)+
P5	MD(1)-
P6	CT
P7	CT
P8	MD(3)+
P9	MD(3)-
P10	MD(0)-
P11	MD(0)+
P12	CT
P13	LEFT LIGHT PIPE
P14	LEFT LIGHT PIPE
P15	RIGHT LIGHT PIPE
P16	RIGHT LIGHT PIPE

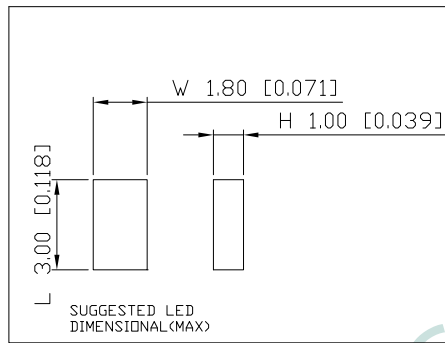

SUGGESTED PCB LAYOUT
(TOP VIEW)
DIMENSIONAL TOLERANCE: .XX ±0.08[0.003]

KRG-011-0-S71-0P0

PRODUCT SERIES
KRG: LATCH DOWN WITH LED

MECHANICAL TYPE
011: 1 PDRT, LENGTH 24.13mm,
HEIGHT=11.70mm, STRAIGHT PINS,
PLASTIC PEG=GROUNDING=2.90mm,
PIN=2.41mm

LED COLOR OPTION

SPECIAL CODE
0: STANDARD

SHIELDED TYPE
P: EMI FINGER ON ALL SIDE
W/D GROUND LUG

LED POLARITY
0: W/D LED

CIRCUIT TYPE

PART NO		KRG-011-0-S71-0P0		
TITLE	RJ45, W/10G TRANSFORMER, W/LIGHT PIPE, SHIELDED			
REV : 03				
UNIT	DRAWN	CHKD	DATE	SHEET
mm[inch]	CINDY	DANIEL	Jan. 03, '18	2 of 5

3. SCHEMATIC :

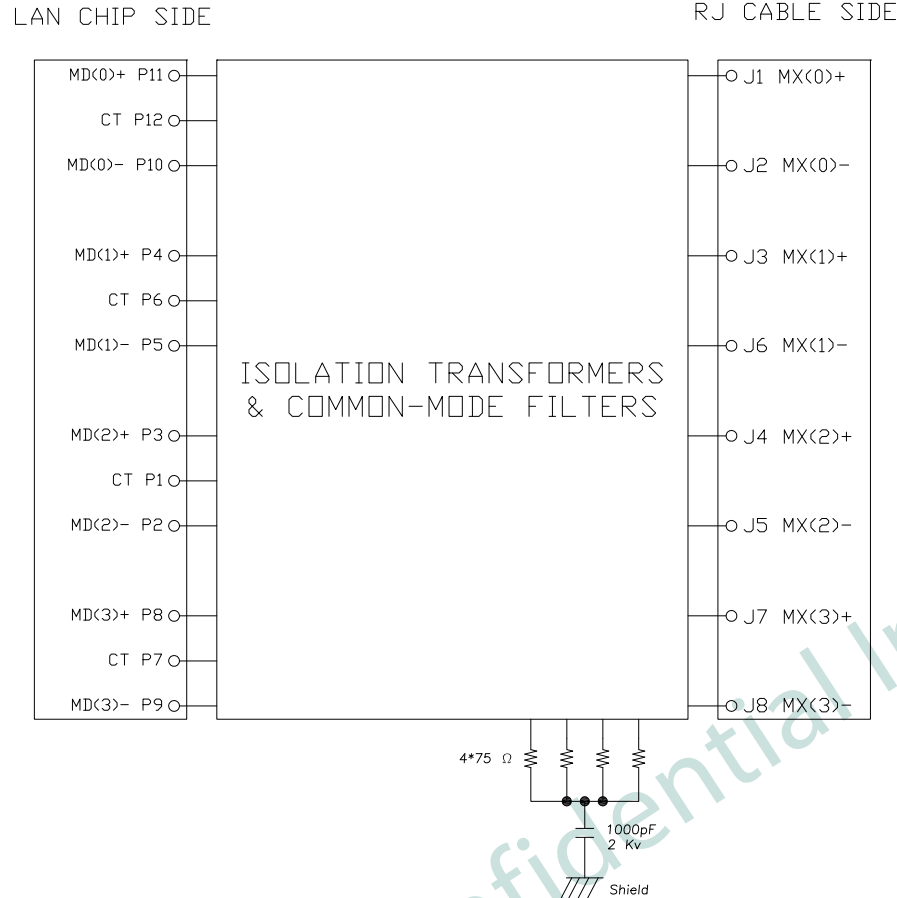

4. ELECTRICAL CHARACTERISTICS :

TEST NOTES:(25°±5°C)

1. INSERTION LOSS:
 -0.6dB MAXIMUM AT 1MHz TO 100MHz
 -1.0dB MAXIMUM AT 100MHz TO 200MHz
 -1.5dB MAXIMUM AT 200MHz TO 300MHz
 -2.0dB MAXIMUM AT 300MHz TO 400MHz
2. RETURN LOSS AT THE PHY SIDE:
 -20dB MINIMUM AT 1MHz TO 100MHz
 -16dB MINIMUM AT 100MHz TO 200MHz
 -10dB MINIMUM AT 200MHz TO 500MHz
 -9dB MINIMUM AT 500MHz TO 600MHz
 -2dB MINIMUM AT 600MHz TO 800MHz
3. CROSS TALK:
 -30dB MINIMUM AT 100MHz TO 500MHz
4. CM TO DM REJECTION:
 -35dB MINIMUM AT 1MHz TO 500MHz
5. CM TO CM REJECTION:
 -10dB MINIMUM AT 1MHz TO 300MHz
 -12dB MINIMUM AT 300MHz TO 400MHz
 -15dB MINIMUM AT 400MHz TO 500MHz
 -16dB MINIMUM AT 500MHz TO 600MHz
6. HIPDT:
 INPUT TO OUTPUT : 1500VAC FOR 60 SECONDS

PART NO		KRG-011-0-S71-0P0		
TITLE	RJ45, W/10G TRANSFORMER, W/LIGHT PIPE, SHIELDED			
REV : 03				
UNIT	DRAWN	CHKD	DATE	SHEET
mm[inch]	CINDY	DANIEL	Jan. 03, '18	3 of 5

5. PACKING SPECIFICATION :

A
B
C
D
E
F

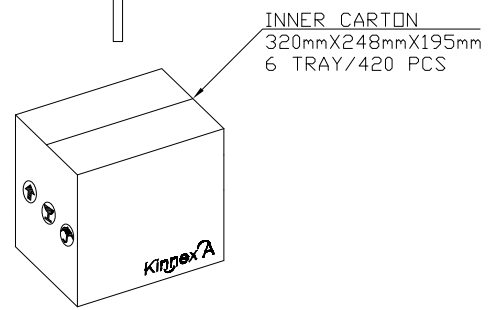
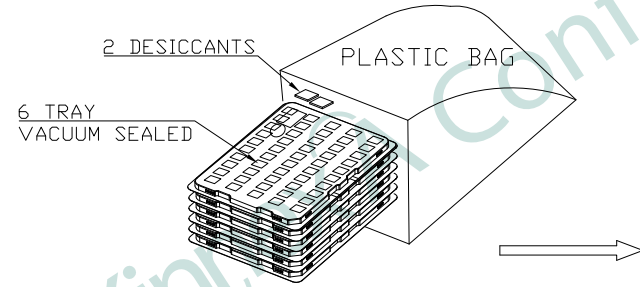
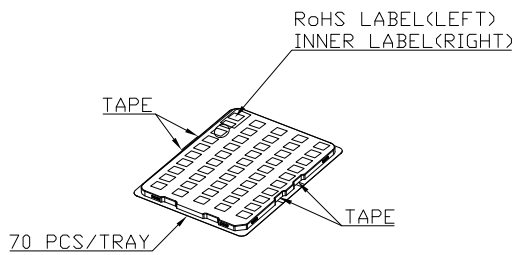
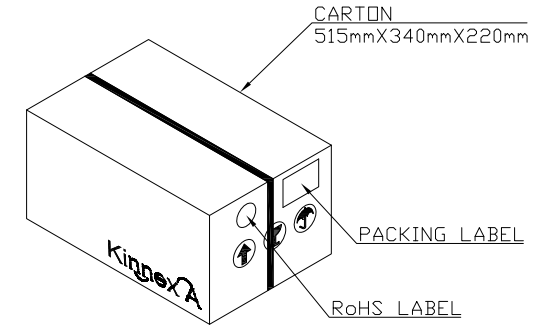
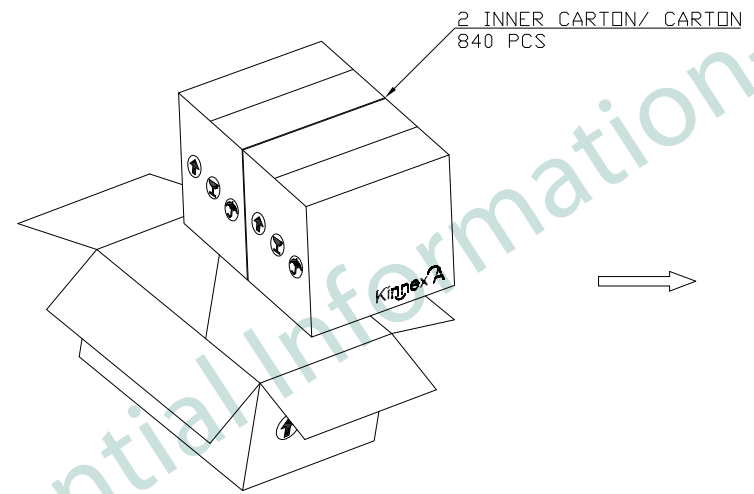
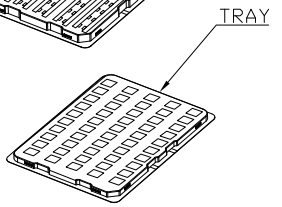
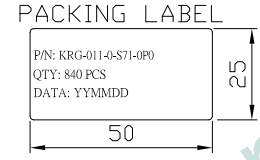
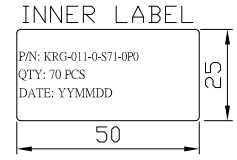
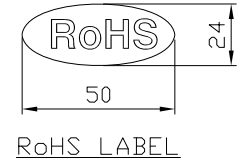
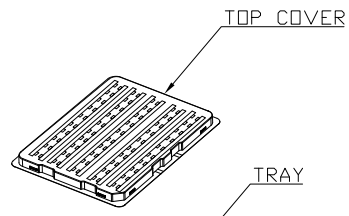

PART NO		KRG-011-0-S71-0P0		
TITLE	RJ45, W/10G TRANSFORMER, W/LIGHT PIPE, SHIELDED			
REV : 03				
UNIT	DRAWN	CHKD	DATE	SHEET
mm[inch]	CINDY	DANIEL	Jan. 03, '18	4 of 5

6. PROFILE OF WAVE SOLDER : 

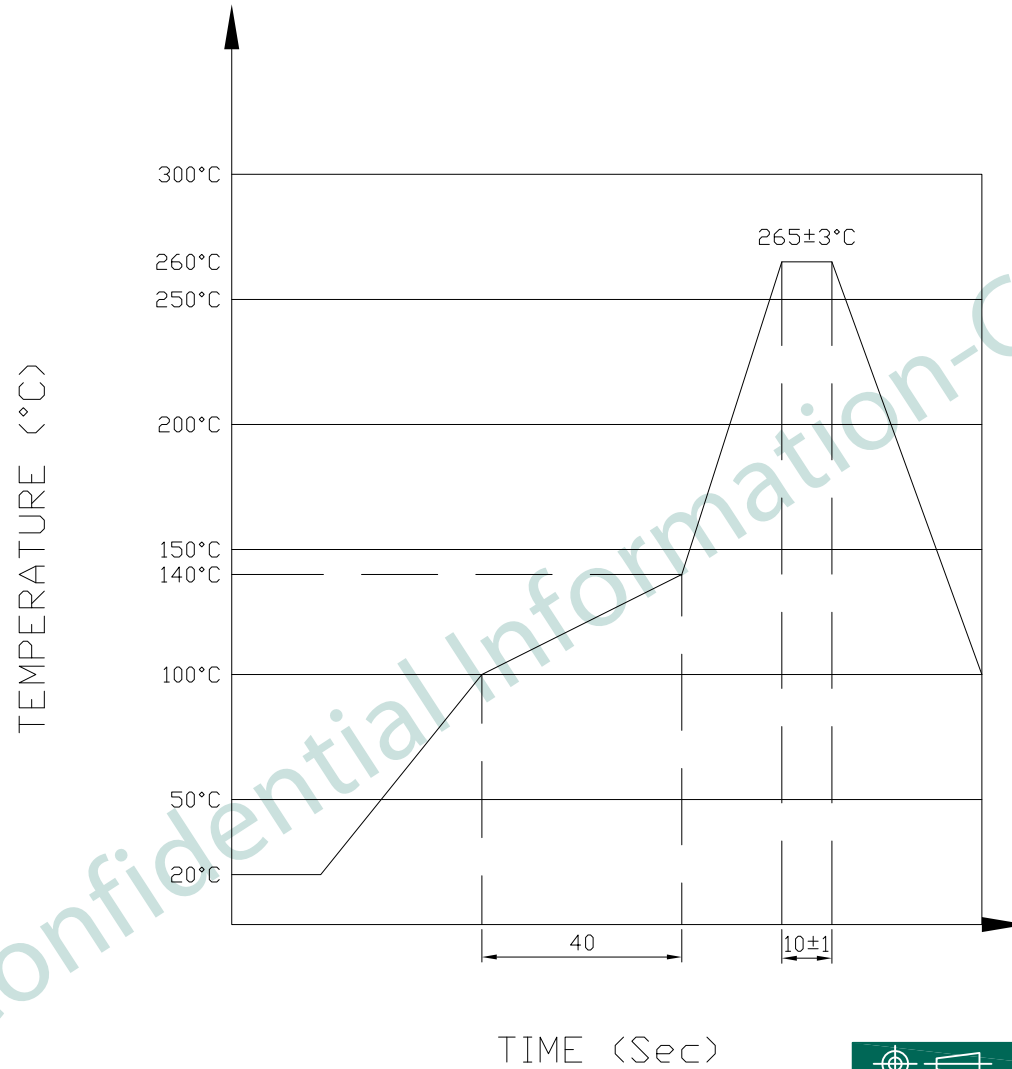

The measuring point for the specified temperature shall be on the soldered part of the lead

 PART NO		KRG-011-0-S71-0P0		
TITLE	RJ45, W/10G TRANSFORMER, W/LIGHT PIPE, SHIELDED			
REV : 03				
UNIT	DRAWN	CHKD	DATE	SHEET
mm[inch]	CINDY	DANIEL	Jan. 03, '18	5 of 5