



<u>Characteristics</u>	<u>Band 1</u>	<u>Band 2</u>
Passband:	1850-1910 MHz	1930-1990 MHz
Bandwidth:	60 MHz	60 MHz
Passband Return Loss:	11 dB min	11 dB min
Passband Insertion Loss:	3.4 dB max	3.4 dB max
Passband Ripple:	2.5 dB min	3 dB min
Input / Output Impedance:	50 Ohms	50 Ohms
Isolation:	51 dB min	42 dB min
Power Handling:	2 W max	2 W max

<u>Mechanical</u>	
Mounting Method:	SMT
Dimensions:	28.2 x 6.85 x 4.9 mm

<u>Environmental</u>	
Operating Temperature:	-40 to +70 deg.C
Storage Temperature:	-50 to +90 deg.C

This product is RoHs compliant.

Outline Drawing:

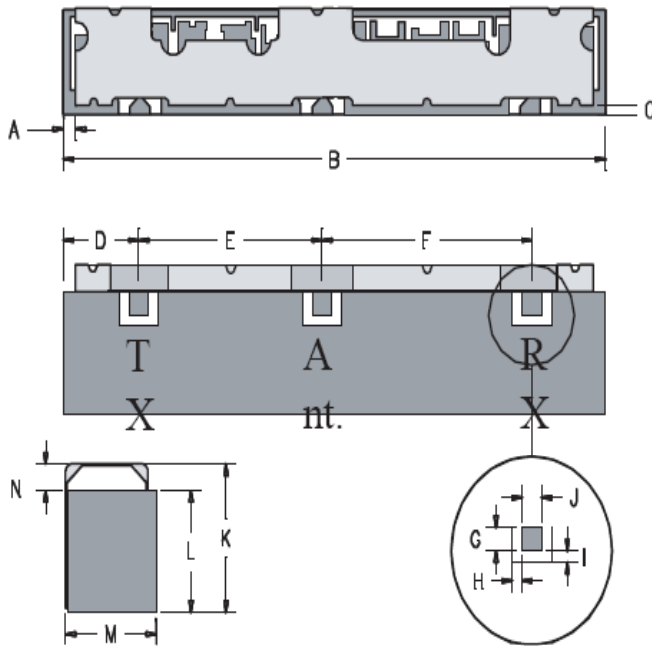

Dim	Nominal (mm)	Tolerance (mm) +/-
A	0.64	0.25
B	28.2	0.28
*C	0.33	Min
D	4	0.3
E	9.45	0.13
F	10.8	0.13
G	1.02	0.13
H	0.51	0.13
I	0.51	0.13
J	1.02	0.13
K	6.85	Max
L	5.95	Max
M	4.9	Max
N	1.07	0.13
*Indicates Reference Only		

Available at our Web store:



Response Plot:

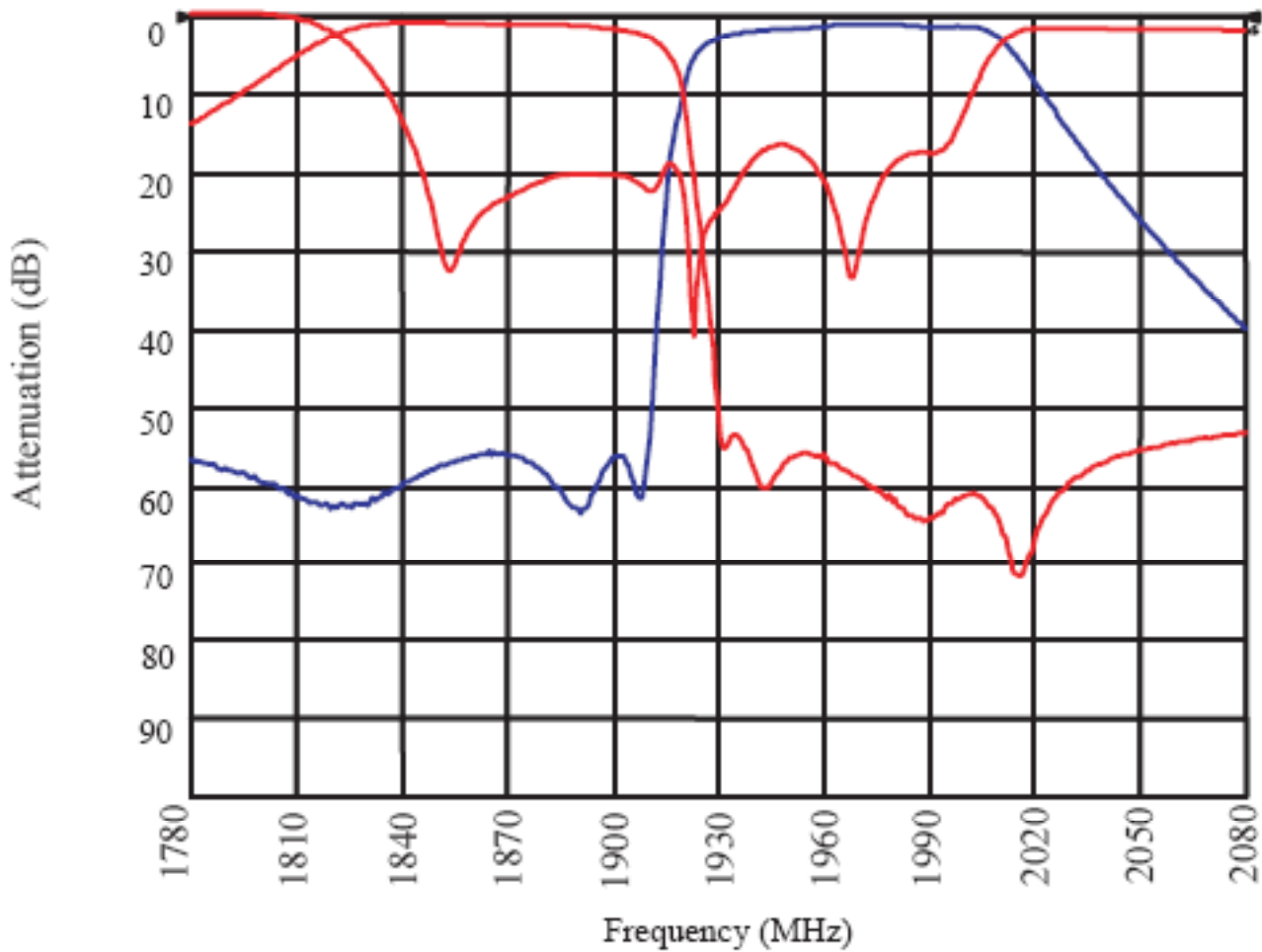

Available at our Web store: