



XICOR CONFIDENTIAL

## Digitally Controlled Potentiometer (XDCP™)

X93155

## FEATURES

- Solid-state potentiometer
- Up/Down interface
- 32 wiper tap points per potentiometer
  - Wiper position stored in nonvolatile memory and recalled on power-up
- 31 resistive elements per potentiometer
  - Temperature compensated
  - Maximum resistance tolerance  $\pm 25\%$
  - Terminal voltage, 0 to  $V_{CC}$
- Low power CMOS
  - $V_{CC} = 5V \pm 10\%$
  - Active current, 200 $\mu$ A typ.
  - Standby current, 2.0 $\mu$ A max
- High reliability
  - Endurance 200,000 data changes per bit
  - Register data retention, 100 years
- $R_{TOTAL}$  value = 50k $\Omega$
- Packages
  - 8-lead MSOP, FCP, TDFN

## DESCRIPTION

The Xicor X93155 is a digitally controlled potentiometer (XDCP). The device consists of a resistor array, wiper switches, a control section, and nonvolatile memory. The wiper position is controlled by a 3-wire interface.

The potentiometer is implemented by a resistor array composed of 31 resistive elements and a wiper switching network. The position of the wiper element is controlled by the  $\overline{CS}$ ,  $U/\overline{D}$ , and  $\overline{INC}$  inputs. The position of the wiper can be stored in nonvolatile memory and then be recalled upon a subsequent power-up operation.

The device is connected as a two-terminal variable resistor and can be used in a wide variety of applications including:

- bias and gain control
- LCD Contrast Adjustment

## BLOCK DIAGRAM

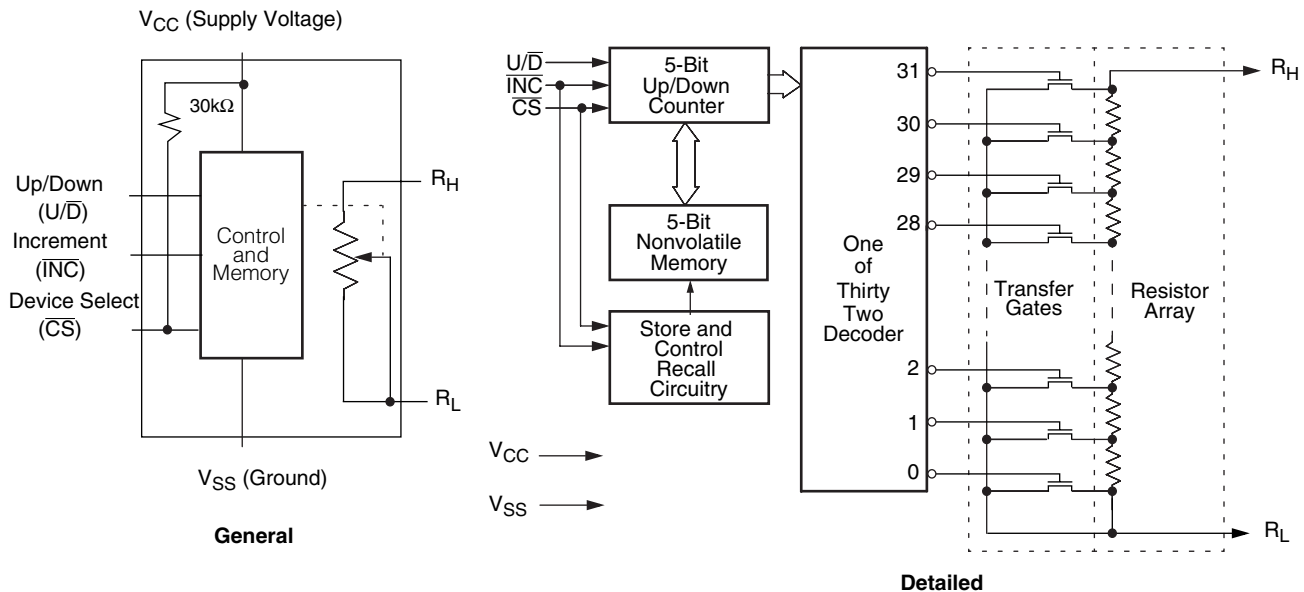

**PIN CONFIGURATION**

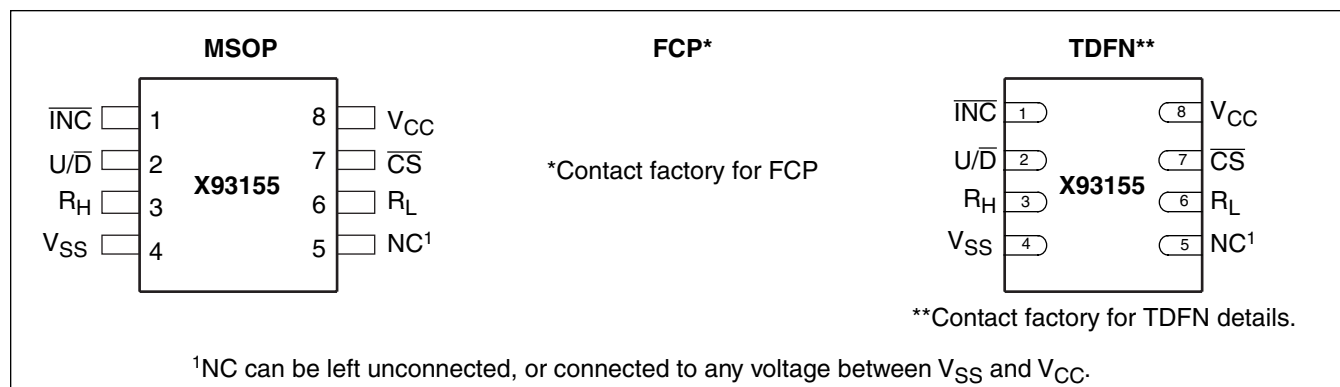

**X93155 ORDERING CODES**

Ordering Number	RTOTAL	Package	Temperature Range
X93155UM8I	50kΩ	8-lead MSOP package	-40°C to +85°C

**PIN DESCRIPTIONS**

MSOP	Symbol	Brief Description
1	$\overline{INC}$	<b>Increment (INC).</b> The $\overline{INC}$ input is negative-edge triggered. Toggling $\overline{INC}$ will move the wiper and either increment or decrement the counter in the direction indicated by the logic level on the $U/\overline{D}$ input.
2	$U/\overline{D}$	<b>Up/Down (U/D).</b> The $U/\overline{D}$ input controls the direction of the wiper movement and whether the counter is incremented or decremented.
3	$R_H$	<b><math>R_H</math>.</b> The $R_H$ and $R_L$ pins of the X93155 are equivalent to the end terminals of a variable resistor.
4	$V_{SS}$	<b>Ground.</b>
5	NC	<b>No Connection.</b> (or can be connected to any voltage between $V_{SS}$ and $V_{CC}$ .)
6	$R_L$	<b><math>R_L</math>.</b> The $R_H$ and $R_L$ pins of the X93155 are equivalent to the end terminals of a variable resistor.
7	$\overline{CS}$	<b>Chip Select (CS).</b> The device is selected when the $\overline{CS}$ input is LOW. The current counter value is stored in nonvolatile memory when $\overline{CS}$ is returned HIGH while the $INC$ input is also HIGH. After the store operation is complete, the X93155 will be placed in the low power standby mode until the device is selected once again.
8	$V_{CC}$	<b>Supply Voltage.</b>

**ABSOLUTE MAXIMUM RATINGS**

Temperature under bias .....-65°C to +135°C  
 Storage temperature ..... -65°C to +150°C  
 Voltage on  $\overline{CS}$ ,  $\overline{INC}$ ,  $U/\overline{D}$ ,  $R_H$ ,  $R_L$  and  $V_{CC}$   
 with respect to  $V_{SS}$  .....-1V to +6.5V  
 Lead temperature (soldering 10 seconds)..... 300°C  
 Maximum reflow temperature (40 seconds) ..... 240°C  
 Maximum resistor current..... 2mA

**COMMENT**

Stresses above those listed under “Absolute Maximum Ratings” may cause permanent damage to the device. This is a stress rating only; the functional operation of the device (at these or any other conditions above those listed in the operational sections of this specification) is not implied. Exposure to absolute maximum rating conditions for extended periods may affect device reliability.

**RECOMMENDED OPERATING CONDITIONS**

Temperature	Min.	Max.
Industrial	-40°C	+85°C

Supply Voltage ( $V_{CC}$ )	Limits
X93155	5V $\pm$ 10% <sup>(7)</sup>

**POTENTIOMETER CHARACTERISTICS** (Over recommended operating conditions unless otherwise stated.)

Symbol	Parameter	Limits				Test Conditions/Notes
		Min.	Typ.	Max.	Unit	
$R_{TOT}$	End to end resistance	37.5	50	62.5	k $\Omega$	
$V_R$	$R_H$ , $R_L$ terminal voltages	0		$V_{CC}$	V	
	Power rating			1	mW <sup>(6)</sup>	$R_{TOTAL} = 50\text{ K}\Omega$
	Noise		-120		dBV <sup>(6)</sup>	Ref: 1kHz
$I_R$	Potentiometer Current			0.6	mA	<sup>(5)</sup>
	Resolution		3		%	
	Absolute linearity <sup>(1)</sup>			$\pm 1$	MI <sup>(3)</sup>	$R_{H(n)}(\text{actual}) - R_{H(n)}(\text{expected})$
	Relative linearity <sup>(2)</sup>			$\pm 0.5$	MI <sup>(3)</sup>	$R_{H(n+1)} - [R_{H(n)} + MI]$
	$R_{TOTAL}$ temperature coefficient		$\pm 35$		ppm/ $^{\circ}\text{C}$	<sup>(6)</sup>
$C_H/C_L/C_W$	Potentiometer capacitances		10/10/25		pF <sup>(6)</sup>	See circuit #2

- Notes:** (1) Absolute linearity is utilized to determine actual wiper resistance versus expected resistance =  $(R_{H(n)}(\text{actual}) - R_{H(n)}(\text{expected})) = \pm 1$  MI Maximum. n = 1 .. 29 only  
 (2) Relative linearity is a measure of the error in step size between taps =  $R_{H(n+1)} - [R_{H(n)} + MI] = \pm 0.5$  MI, n = 1 .. 29 only.  
 (3) 1 MI = Minimum Increment =  $R_{TOT}/31$ .  
 (4) Typical values are for  $T_A = 25^{\circ}\text{C}$  and nominal supply voltage.  
 (5) This parameter is periodically sampled and not 100% tested  
 (6) This parameter is not 100% tested.  
 (7) When performing multiple write operations,  $V_{CC}$  must not decrease by more than 150mV from its initial value.

**D.C. OPERATING CHARACTERISTICS** (Over recommended operating conditions unless otherwise specified.)

Symbol	Parameter	Limits			Unit	Test Conditions
		Min.	Typ.(4)	Max.		
I <sub>CC1</sub>	V <sub>CC</sub> active current (Increment)		200	300	μA	$\overline{CS} = V_{IL}$ , $U/\overline{D} = V_{IL}$ or $V_{IH}$ and $\overline{INC} = 0.4V$ @ max. $t_{CYC}$
I <sub>CC2</sub>	V <sub>CC</sub> active current (Store) (EEPROM Store)			1400	μA	$\overline{CS} = V_{IH}$ , $U/\overline{D} = V_{IL}$ or $V_{IH}$ and $\overline{INC} = V_{IH}$ @ max. $t_{WR}$
I <sub>SB</sub>	Standby supply current			2.0	μA	$\overline{CS} = V_{CC} - 0.3V$ , $U/\overline{D}$ and $\overline{INC} = V_{SS}$ or $V_{CC} - 0.3V$
I <sub>LI</sub>	$\overline{CS}$			±1	μA	$V_{\overline{CS}} = V_{CC}$
I <sub>LI</sub>	$\overline{CS}$	120	200	250	μA	$V_{CC} = 5V$ , $\overline{CS} = 0$
I <sub>LI</sub>	$\overline{INC}$ , $U/\overline{D}$ input leakage current			±1	μA	$V_{IN} = V_{SS}$ to $V_{CC}$
V <sub>IH</sub>	$\overline{CS}$ , $\overline{INC}$ , $U/\overline{D}$ input HIGH voltage	$V_{CC} \times 0.7$		$V_{CC} + 0.5$	V	
V <sub>IL</sub>	$\overline{CS}$ , $\overline{INC}$ , $U/\overline{D}$ input LOW voltage	-0.5		$V_{CC} \times 0.1$	V	
C <sub>IN</sub> (5)(7)	$\overline{CS}$ , $\overline{INC}$ , $U/\overline{D}$ input capacitance			10	pF	$V_{CC} = 5V$ , $V_{IN} = V_{SS}$ , $T_A = 25^\circ C$ , $f = 1MHz$

**ENDURANCE AND DATA RETENTION**

Parameter	Min.	Unit
Minimum endurance	200,000	Data changes per bit
Data retention	100	Years

**Test Circuit #1**

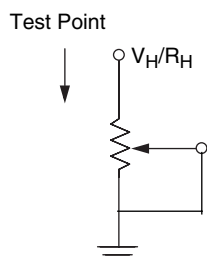

**Circuit #2 SPICE Macro Model**

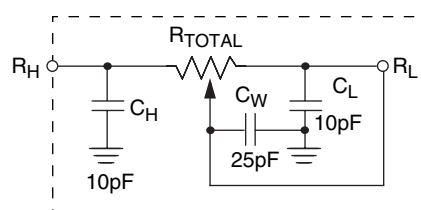

**A.C. CONDITIONS OF TEST**

Input pulse levels	0V to 5V
Input rise and fall times	10ns
Input reference levels	1.5V

**A.C. OPERATING CHARACTERISTICS** (Over recommended operating conditions unless otherwise specified)

Symbol	Parameter	Limits			Unit
		Min.	Typ.(6)	Max.	
$t_{CI}$	$\overline{CS}$ to $\overline{INC}$ setup	100			ns
$t_{ID}$	$\overline{INC}$ HIGH to $U/\overline{D}$ change	100			ns
$t_{DI}$	$U/\overline{D}$ to $\overline{INC}$ setup	100			ns
$t_{IL}$	$\overline{INC}$ LOW period	1			$\mu$ s
$t_{IH}$	$\overline{INC}$ HIGH period	1			$\mu$ s
$t_{IC}$	$\overline{INC}$ Inactive to $\overline{CS}$ inactive	1			$\mu$ s
$t_{CPH}$	$\overline{CS}$ Deselect time (NO STORE)	250			ns
$t_{CPH}$	$\overline{CS}$ Deselect time (STORE)	10			ms
$t_{CYC}$	$\overline{INC}$ cycle time	2			$\mu$ s
$t_R, t_F^{(6)}$	$\overline{INC}$ input rise and fall time			500	$\mu$ s
$t_{R VCC}^{(6)}$	$V_{CC}$ power-up rate	1		10,000	V/ms
$t_{WR}$	Store cycle		5	10	ms

**POWER UP AND DOWN REQUIREMENTS**

There are no restrictions on the power-up or power-down conditions of  $V_{CC}$  and the voltages applied to the potentiometer pins provided that  $V_{CC}$  is always more positive than or equal to  $V_H$  and  $V_L$ , i.e.,  $V_{CC} \geq V_H, V_L$ . The  $V_{CC}$  ramp rate spec is always in effect.

**A.C. TIMING**

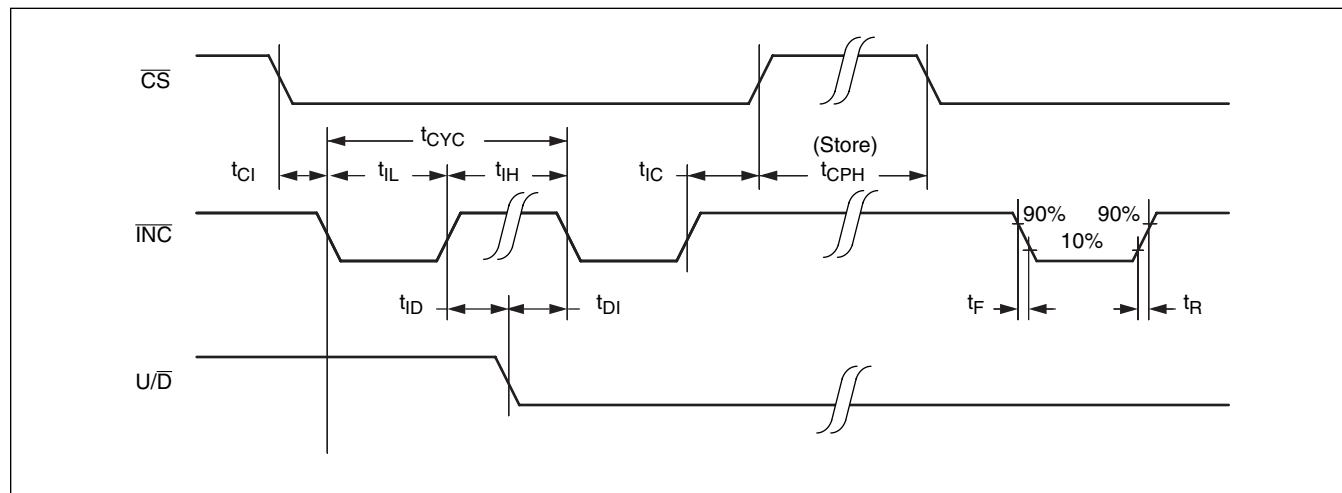

## **PIN DESCRIPTIONS**

### **$R_H$ and $R_L$**

The  $R_H$  and  $R_L$  pins of the X93155 are equivalent to the end terminals of a variable resistor. The minimum voltage is  $V_{SS}$  and the maximum is  $V_{CC}$ . The terminology of  $R_H$  and  $R_L$  references the relative position of the terminal in relation to wiper movement direction selected by the  $U/\overline{D}$  input.

### **Up/Down ( $U/\overline{D}$ )**

The  $U/\overline{D}$  input controls the direction of the wiper movement and whether the counter is incremented or decremented.

### **Increment ( $\overline{INC}$ )**

The  $\overline{INC}$  input is negative-edge triggered. Toggling  $\overline{INC}$  will move the wiper and either increment or decrement the counter in the direction indicated by the logic level on the  $U/\overline{D}$  input.

### **Chip Select ( $\overline{CS}$ )**

The device is selected when the  $\overline{CS}$  input is LOW. The current counter value is stored in nonvolatile memory when  $\overline{CS}$  is returned HIGH while the  $\overline{INC}$  input is also HIGH. After the store operation is complete the X93155 will be placed in the low power standby mode until the device is selected once again.

## **PRINCIPLES OF OPERATION**

There are three sections of the X93155: the input control, counter and decode section; the nonvolatile memory; and the resistor array. The input control section operates just like an up/down counter. The output of this counter is decoded to turn on a single electronic switch connecting a point on the resistor array to the wiper output. Under the proper conditions the contents of the counter can be stored in nonvolatile memory and retained for future use. The resistor array is comprised of 31 individual resistors connected in series. At either end of the array and between each resistor is an electronic switch that transfers the connection at that point to the wiper. The wiper is connected to the  $R_L$  terminal, forming a variable resistor from  $R_H$  to  $R_L$ .

The wiper, when at either fixed terminal, acts like its mechanical equivalent and does not move beyond the last position. That is, the counter does not wrap around when clocked to either extreme.

If the wiper is moved several positions, multiple taps are connected to the wiper for up to 10 $\mu$ s. The 2-terminal resistance value for the device can temporarily change by a significant amount if the wiper is moved several positions.

When the device is powered-down, the last wiper position stored will be maintained in the nonvolatile memory. When power is restored, the contents of the memory are recalled and the wiper is set to the value last stored.

**INSTRUCTIONS AND PROGRAMMING**

The  $\overline{INC}$ ,  $U/\overline{D}$  and  $\overline{CS}$  inputs control the movement of the wiper along the resistor array. With  $\overline{CS}$  set LOW the device is selected and enabled to respond to the  $U/\overline{D}$  and  $\overline{INC}$  inputs. HIGH to LOW transitions on  $\overline{INC}$  will increment or decrement (depending on the state of the  $U/\overline{D}$  input) a five bit counter. The output of this counter is decoded to select one of thirty two wiper positions along the resistive array.

The value of the counter is stored in nonvolatile memory whenever  $\overline{CS}$  transitions HIGH while the  $\overline{INC}$  input is also HIGH. In order to avoid an accidental store during power-up,  $\overline{CS}$  must go HIGH with  $V_{CC}$  during initial power-up. When left open, the  $\overline{CS}$  pin is internally pulled up to  $V_{CC}$  by an internal 30k $\Omega$  resistor.

The system may select the X93155, move the wiper and deselect the device without having to store the latest wiper position in nonvolatile memory. After the wiper movement is performed as described above and once the new position is reached, the system must keep  $\overline{INC}$  LOW while taking  $\overline{CS}$  HIGH. The new wiper position will be maintained until changed by the system or until a power-up/down cycle recalled the previously stored data. In order to recall the stored position of the wiper on power-up, the  $\overline{CS}$  pin must be held HIGH.

This procedure allows the system to always power-up to a preset value stored in nonvolatile memory; then during system operation minor adjustments could be made. The adjustments might be based on user preference, system parameter changes due to temperature drift, or other system trim requirements.

The state of  $U/\overline{D}$  may be changed while  $\overline{CS}$  remains LOW. This allows the host system to enable the device and then move the wiper up and down until the proper trim is attained.

**MODE SELECTION**

$\overline{CS}$	$\overline{INC}$	$U/\overline{D}$	Mode
L		H	Wiper Up
L		L	Wiper Down
	H	X	Store Wiper Position
H	X	X	Standby Current
	L	X	No Store, Return to Standby
	L	H	Wiper Up (not recommended)
	L	L	Wiper Down (not recommended)

**SYMBOL TABLE**

WAVEFORM	INPUTS	OUTPUTS
	Must be steady	Will be steady
	May change from Low to High	Will change from Low to High
	May change from High to Low	Will change from High to Low
	Don't Care: Changes Allowed	Changing: State Not Known
	N/A	Center Line is High Impedance

**APPLICATIONS INFORMATION**

Electronic digitally controlled (XDCP) potentiometers provide three powerful application advantages; (1) the variability and reliability of a solid-state potentiometer (2) the flexibility of computer-based digital controls, and (3) the retentivity of nonvolatile memory used for the storage of multiple potentiometer settings or data.

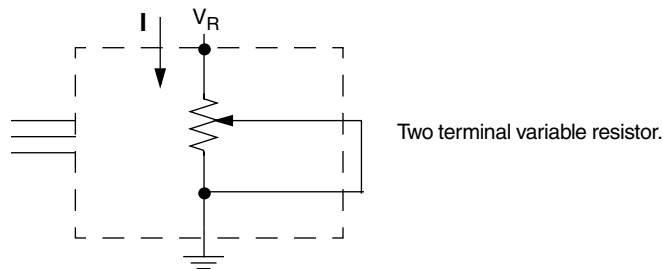

**Low Voltage High Impedance Instrumentation Amplifier**

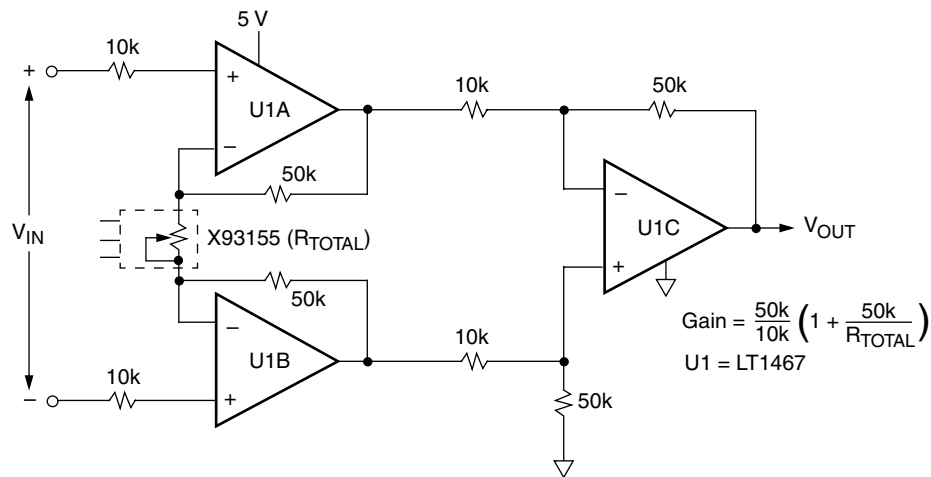

**Micro-Power LCD Contrast Control**

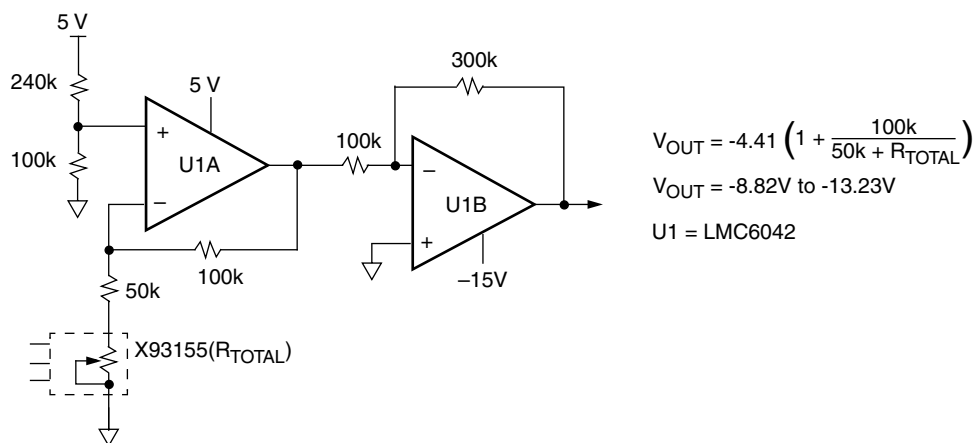



## APPLICATIONS INFORMATION (Continued)

## Single Supply Variable Gain Amplifier

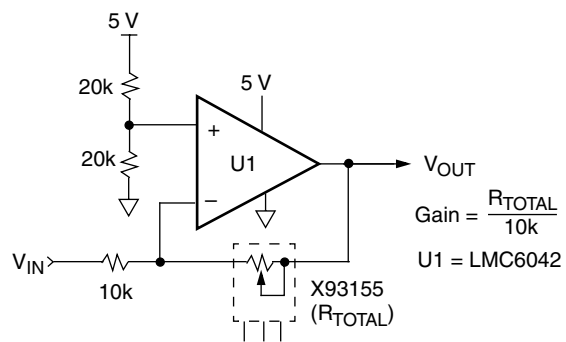

MSOP PACKAGING INFORMATION

8-Lead Miniature Small Outline Gull Wing Package Type M

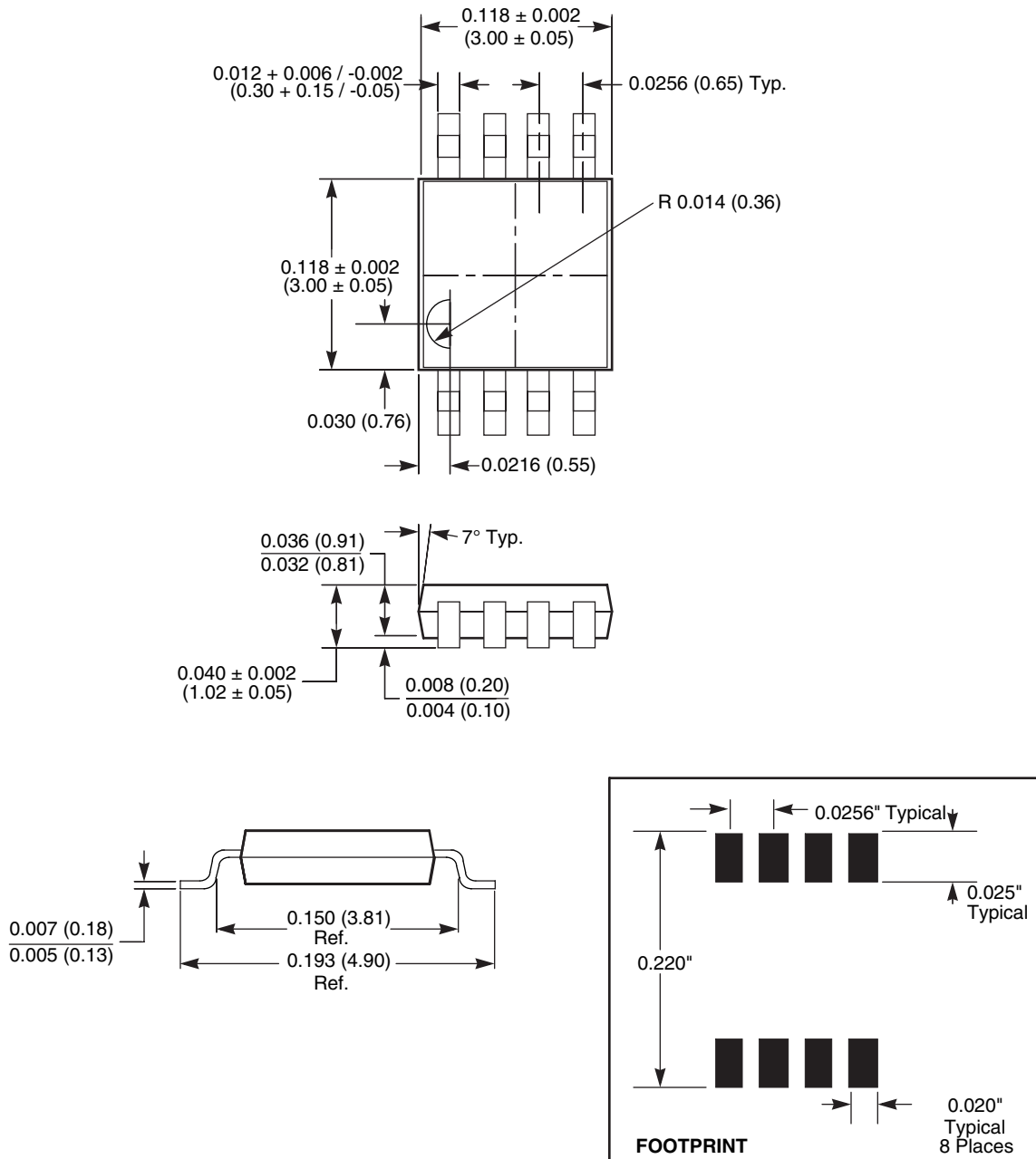

**NOTE:**  
1. ALL DIMENSIONS IN INCHES AND (MILLIMETERS)

8 BUMP FCP PACKAGE

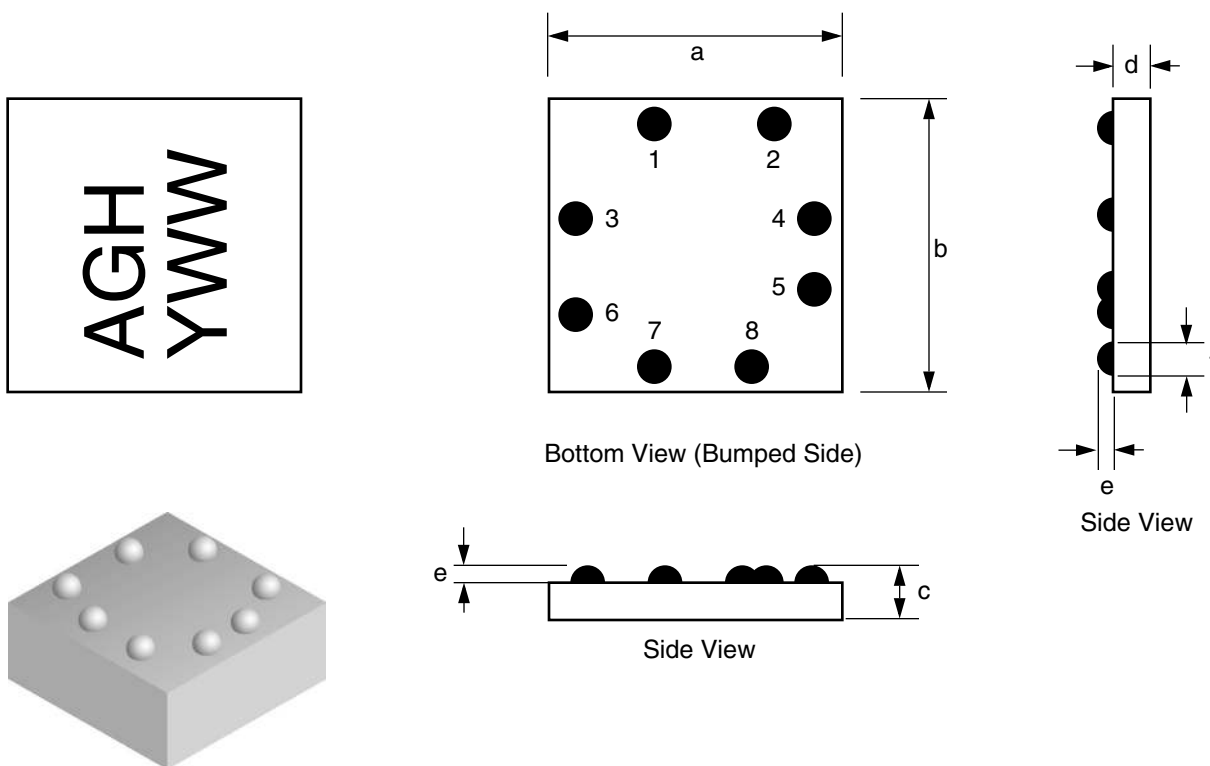

	Symbol	Min	Nominal	Max
		Millimeters		
Package Width	A	0.960	0.990	1.020
Package Length	B	0.940	0.970	1.000
Package Height	C	0.700	0.730	0.760
Body Thickness	D	0.620	0.630	0.640
Ball Height	E	0.085	0.100	0.115
Ball Diameter	F	0.100	0.115	0.130

	Bump Name	X coordinate, $\mu\text{m}$	Y coordinate, $\mu\text{m}$
1	INCb	-153.70	377.00
2	Vcc	257.50	375.60
3	UDb	-382.00	123.20
4	CSb	382.00	114.50
5	RL	382.00	-136.30
6	RH	-382.00	-275.10
7	Vss	-115.30	-377.00
8	NC	190.10	-377.00

## TDFN PACKAGING INFORMATION

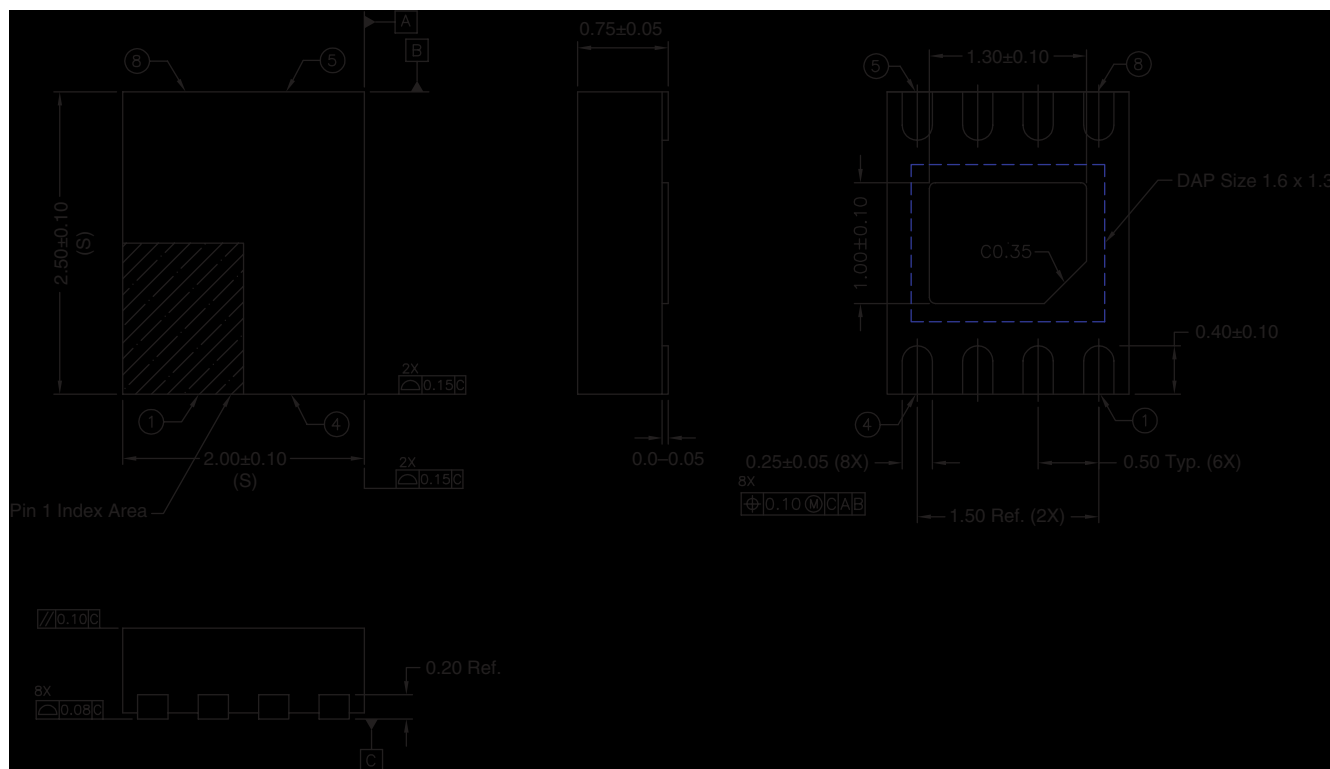
**LIMITED WARRANTY**

©Xicor, Inc. 2004 Patents Pending

Devices sold by Xicor, Inc. are covered by the warranty and patent indemnification provisions appearing in its Terms of Sale only. Xicor, Inc. makes no warranty, express, statutory, implied, or by description regarding the information set forth herein or regarding the freedom of the described devices from patent infringement. Xicor, Inc. makes no warranty of merchantability or fitness for any purpose. Xicor, Inc. reserves the right to discontinue production and change specifications and prices at any time and without notice.

Xicor, Inc. assumes no responsibility for the use of any circuitry other than circuitry embodied in a Xicor, Inc. product. No other circuits, patents, or licenses are implied.

**TRADEMARK DISCLAIMER:**

Xicor and the Xicor logo are registered trademarks of Xicor, Inc. AutoStore, Direct Write, Block Lock, SerialFlash, MPS, BiasLock and XDCP are also trademarks of Xicor, Inc. All others belong to their respective owners.

**U.S. PATENTS**

Xicor products are covered by one or more of the following U.S. Patents: 4,326,134; 4,393,481; 4,404,475; 4,450,402; 4,486,769; 4,488,060; 4,520,461; 4,533,846; 4,599,706; 4,617,652; 4,668,932; 4,752,912; 4,829,482; 4,874,967; 4,883,976; 4,980,859; 5,012,132; 5,003,197; 5,023,694; 5,084,667; 5,153,880; 5,153,691; 5,161,137; 5,219,774; 5,270,927; 5,324,676; 5,434,396; 5,544,103; 5,587,573; 5,835,409; 5,977,585. Foreign patents and additional patents pending.

**LIFE RELATED POLICY**

In situations where semiconductor component failure may endanger life, system designers using this product should design the system with appropriate error detection and correction, redundancy and back-up features to prevent such an occurrence.

Xicor's products are not authorized for use in critical components in life support devices or systems.

1. Life support devices or systems are devices or systems which, (a) are intended for surgical implant into the body, or (b) support or sustain life, and whose failure to perform, when properly used in accordance with instructions for use provided in the labeling, can be reasonably expected to result in a significant injury to the user.
2. A critical component is any component of a life support device or system whose failure to perform can be reasonably expected to cause the failure of the life support device or system, or to affect its safety or effectiveness.