



**ZLP12800100ZACG
Crimzon™
Development Board
Accessory Kit**

PUG002401-0806



Product User Guide

Introduction

Thank you for purchasing the ZiLOG ZLP12800100ZACG Crimzon™ Development Board Accessory Kit (Figure 1). The Crimzon™ Development Board Accessory Kit is designed for use as a target with the Crimzon™ In-Circuit Emulator (ZLP128ICE01ZEMG). The kit is powered by two 1.5V AAA batteries.

The board can also be powered using an adjustable DC power supply connected between terminals J7 (VBAT) and J6 (GND).

This startup guide tells you how to install the batteries supplied with the accessory kit and how to verify proper development board operation.

Kit Contents

- One (1) Crimzon development board with no silicon installed
- Two (2) 1.5V AAA batteries

Applying Power to the Kit

To apply power to the development kit:

1. Install the two (2) AAA batteries in the battery holder on the bottom of the development board. When installing the batteries, ensure that the batteries are fully seated in the battery holder by rotating each battery after snapping it into place.
2. Set the On-Off switch (Figure 1) to the ON position.

Refer to the *Crimzon In-Circuit Emulator User Manual*, UM0184, for details using the development board accessory kit to develop IR applications.

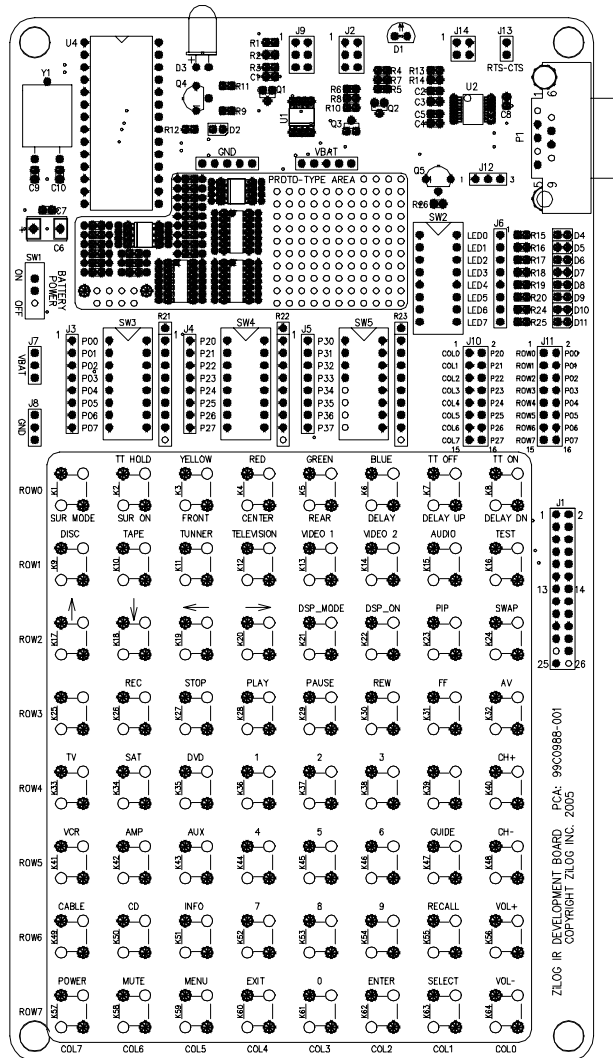

Figure 1. The ZiLOG Crimzon™ Development Board Accessory Kit



This publication is subject to replacement by a later edition. To determine whether a later edition exists, or to request copies of publications, contact:

ZiLOG Worldwide Headquarters

532 Race Street
San Jose, CA 95126
Telephone: 408.558.8500
Fax: 408.558.8300
www.ZiLOG.com

Document Disclaimer

ZiLOG is a registered trademark of ZiLOG Inc. in the United States and in other countries. All other products and/or service names mentioned herein may be trademarks of the companies with which they are associated.

©2006 by ZiLOG, Inc. All rights reserved. Information in this publication concerning the devices, applications, or technology described is intended to suggest possible uses and may be superseded. ZiLOG, INC. DOES NOT ASSUME LIABILITY FOR OR PROVIDE A REPRESENTATION OF ACCURACY OF THE INFORMATION, DEVICES, OR TECHNOLOGY DESCRIBED IN THIS DOCUMENT. ZiLOG ALSO DOES NOT ASSUME LIABILITY FOR INTELLECTUAL PROPERTY INFRINGEMENT RELATED IN ANY MANNER TO USE OF INFORMATION, DEVICES, OR TECHNOLOGY DESCRIBED HEREIN OR OTHERWISE. Devices sold by ZiLOG, Inc. are covered by warranty and limitation of liability provisions appearing in the ZiLOG, Inc. Terms and Conditions of Sale. ZiLOG, Inc. makes no warranty of merchantability or fitness for any purpose Except with the express written approval of ZiLOG, use of information, devices, or technology as critical components of life support systems is not authorized. No licenses are conveyed, implicitly or otherwise, by this document under any intellectual property rights.

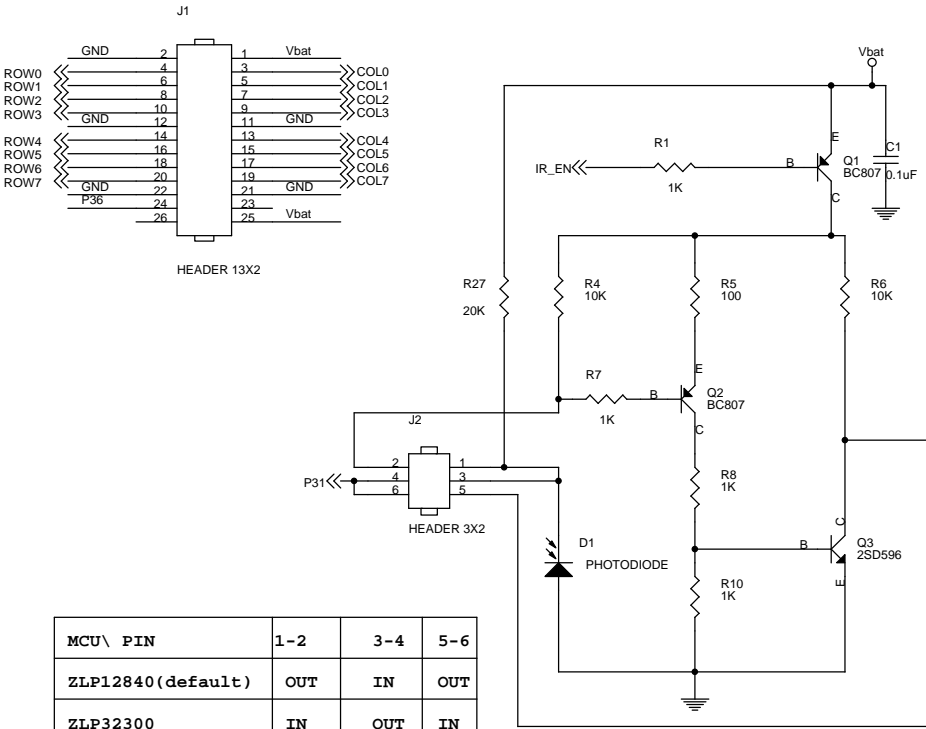

MCU\ PIN	1-2	3-4	5-6
ZLP12840 (default)	OUT	IN	OUT
ZLP32300	IN	OUT	IN

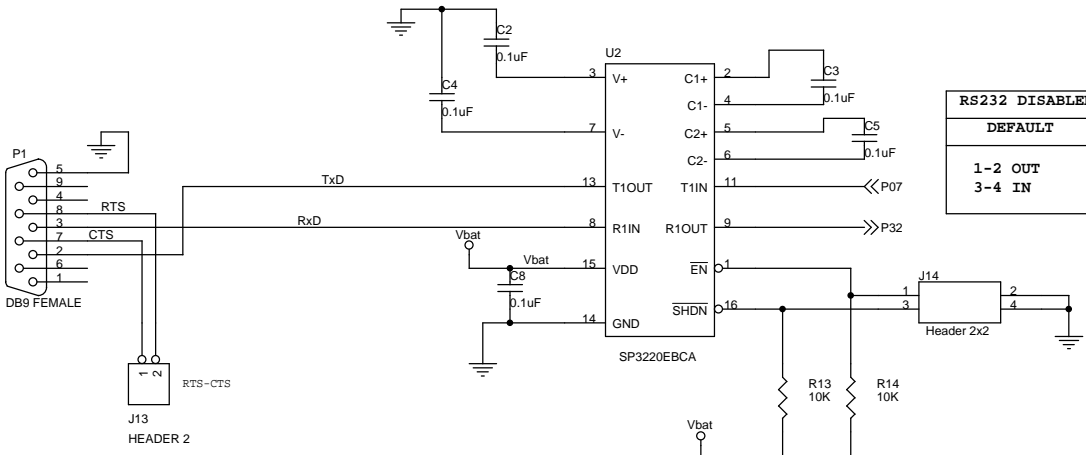
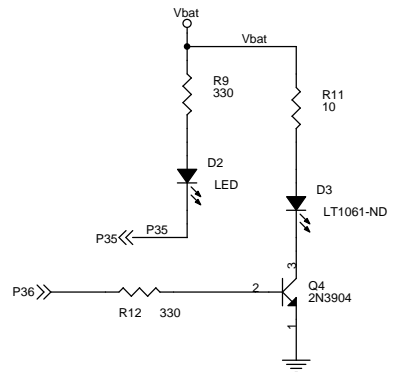
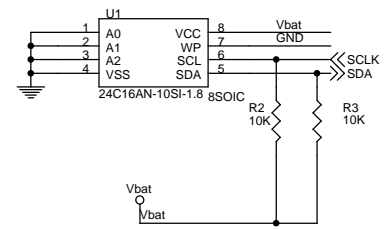
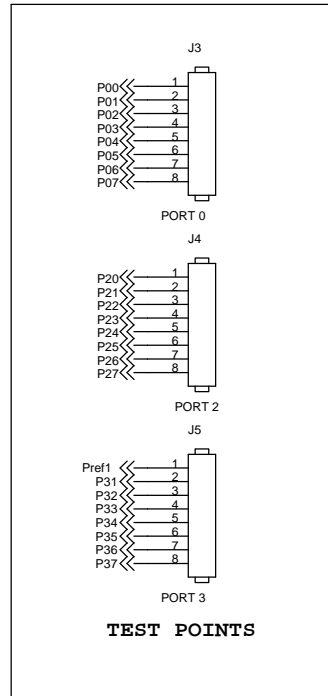

RS232 DISABLED	RS232 ENABLED
DEFAULT	
1-2 OUT	1-2 IN
3-4 IN	3-4 OUT

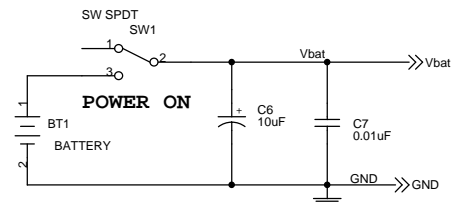
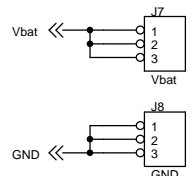

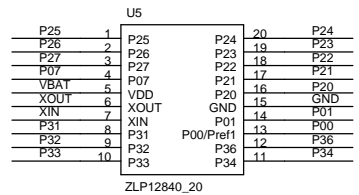
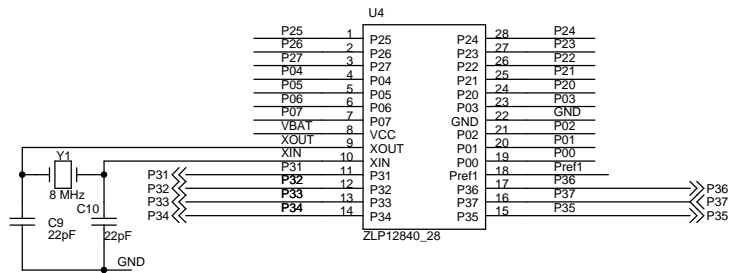

DEFAULT
1-2 OFF
3-4 ON
5-6 ON

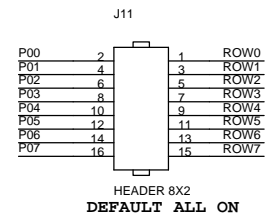
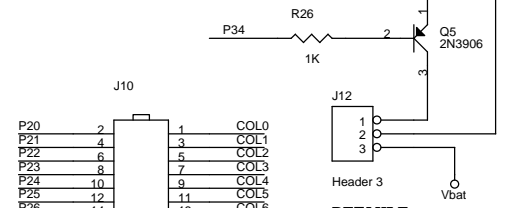
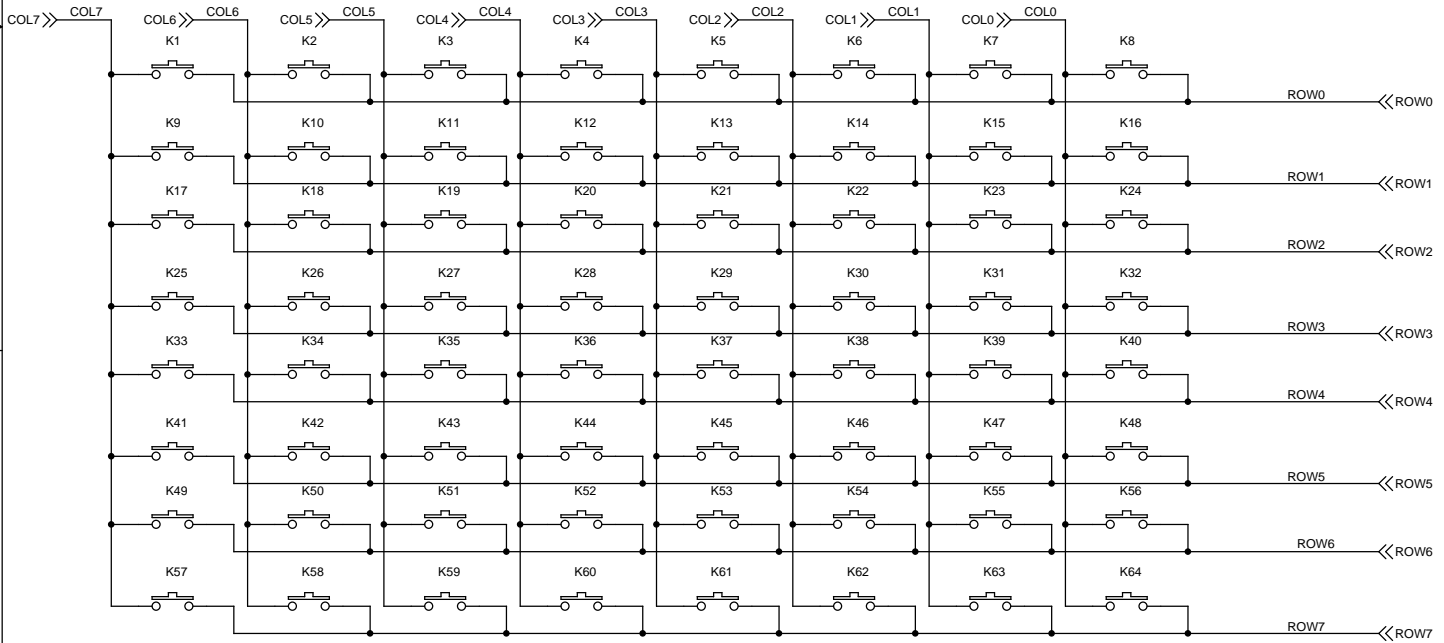
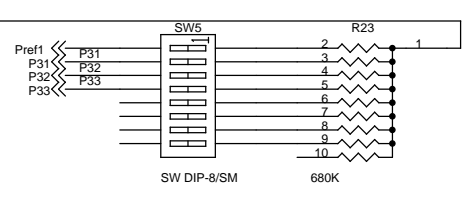
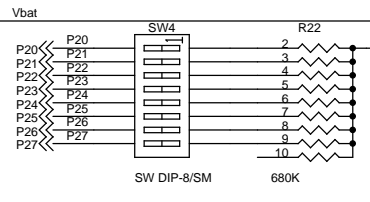
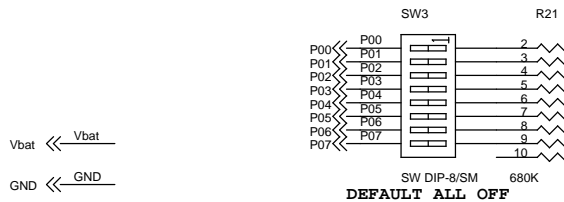
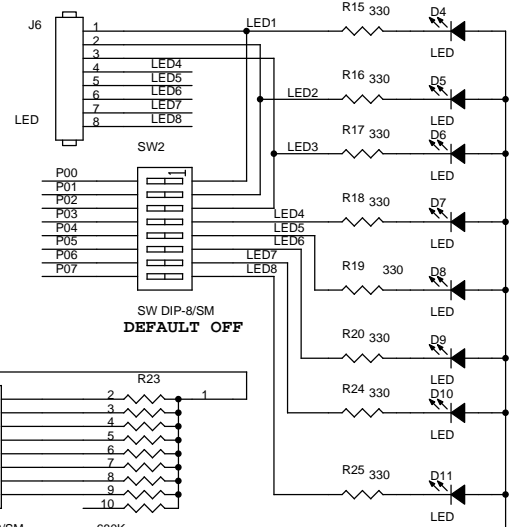
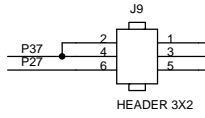

ZiLOG, Inc.
 532 Race Street
 San Jose, CA 95126

Title			IR Development Board		
Size	Document Number		96C0988-001		Rev
B					B
Date:	Monday, August 22, 2005	Sheet	2	of	2