

UCD90320EVM-783 32-Rail Sequencer Development Board

This user's guide describes the UCD90320 sequencer development board (UCD90320EVM-783). The test setup and software setup are detailed and test procedures are outlined. Also included in this document are the schematics, and bill of materials (BOM).

Contents

1	Introduction	2
2	Description	2
	2.1 Typical Applications	2
	2.2 Features.....	2
3	Electrical Performance Specifications.....	3
4	Schematic.....	4
5	Test Setup.....	11
	5.1 Test Equipment.....	11
	5.2 Recommended Test Setup.....	11
	5.3 List of Connectors and Functions	12
	5.4 List of Test Points	17
6	Software Setup	17
	6.1 Fusion Digital Power Designer Software (Fusion GUI) Installation	17
7	Test Procedure	17
	7.1 Voltage Monitoring Example	17
	7.2 Rail Enable Example.....	18
	7.3 Fault Log Example (Including Blackbox Log).....	18
	7.4 Command GPO Example	18
	7.5 GPI and Logic GPO Example	18
	7.6 Margin Example	18
	7.7 Cascading Example.....	18
8	EVM Assembly Drawing and PCB Layout	20
9	Bill of Material	28

List of Figures

1	UCD90320EVM-783.....	4
2	UCD90320EVM-783 Schematic (1 of 6).....	5
3	UCD90320EVM-783 Schematic (2 of 6).....	6
4	UCD90320EVM-783 Schematic (3 of 6).....	7
5	UCD90320EVM-783 Schematic (4 of 6).....	8
6	UCD90320EVM-783 Schematic (5 of 6).....	9
7	UCD90320EVM-783 Schematic (6 of 6)	10
8	UCD90320EVM-783 Recommended Test Setup	11
9	Top Assembly Drawing.....	20
10	Bottom Assembly Drawing	20
11	Top Overlay	21
12	Top Solder Mask	21

SWIFT is a trademark of Texas Instruments.
 Microsoft, Windows are registered trademarks of Microsoft Corporation.
 All other trademarks are the property of their respective owners.

13	Top Layer	22
14	Mid Layer 1	22
15	Mid Layer 2	23
16	Mid Layer 3	23
17	Mid Layer 4	24
18	Bottom Layer.....	24
19	Bottom Solder Mask	25
20	Bottom Overlay	25
21	Drill Drawing	26
22	Board Dimensions.....	27

List of Tables

1	UCD90320EVM-783 Electrical Performance Specifications	3
2	Connector Definitions	12
3	Test Points Functions.....	17
4	UCD90320EVM-783 BOM	28

1 Introduction

The UCD90320 device is a 32-rail PMBus power sequencer and system manager. It can sequence, monitor and margin 32 voltage rails; monitor and respond to user-defined faults such as OV, UV, OC, UC, temperature, time-out, and GPI-triggered faults; provide flexible configurations such as sequence-on and sequence-off dependencies, delay time, and Boolean logic; store fault logs into nonvolatile memory; and integrate value-added features such as watchdog, system reset, cascading and sync clock.

2 Description

The UCD90320EVM-783 contains a UCD90320 device, two step-down power stages using TPS54678 synchronous step-down switcher with integrated FET (SWIFT™), two TPS7A84 LDOs, a TPS73633 LDO, and a REF5030A voltage reference. Access to all of the I/O pins is provided via strip connectors for integration into complex systems using jumper wires. The UCD90320EVM provides PMBus (power management bus) communication port. Microsoft® Windows® based host computers can monitor, control, and configure the UCD90320 device using a USB interface adapter EVM (HPA172) and TI fusion digital power designer graphical user interface (GUI).

2.1 Typical Applications

This EVM is used in the following applications:

- Industrial / ATE
- Telecom / Networking equipment
- Servers and storage systems
- Any system requiring sequencing and monitoring of multiple power rails

2.2 Features

The EVM has the following features:

- Powered by single 5-V supply
- Status LEDs on all digital I/O pins
- Strip connector I/O access
- Headers with pull-up and pull-down configurations
- PMBus interface for configuration and monitoring

3 Electrical Performance Specifications

Table 1 lists the EVM electrical performance specifications.

Table 1. UCD90320EVM-783 Electrical Performance Specifications

Parameter	Test Conditions	MIN	TYP	MAX	Units
Input power					
Input voltage range		4.5	5	5.5	V
Input current	All LEDs and power converters are on. No external load current on I/O pins or power converters.	166	167	169	mA
LDO and Step-down Converter for Margining Function Demonstration					
Output voltage	Normal operation, not in margin mode		1.2		V
Output current	Each LDO or step-down converter.			3	A
Analog Input					
Analog input voltage range	Use internal reference	0	-	3.3	V
Analog input voltage range	Use external reference	0	-	3	V
Digital inputs and outputs					
I/O high-level input voltage ⁽¹⁾		2.15	-	5.5	V
I/O low-level input voltage		0	-	1.15	V
I/O input hysteresis		0.2	-	-	V
I/O high-level output voltage	Load current (source) = -4 mA	2.4	-	-	V
I/O low-level output voltage	Load current (sink) = 4 mA	-	-	0.4	V

⁽¹⁾ Maximum input voltage for PMBUS_CNTRL, PMBALERT#, MAR19 and MAR20 pins are V33D + 0.3 V.

4 Schematic

Figure 1 illustrates the EVM board.

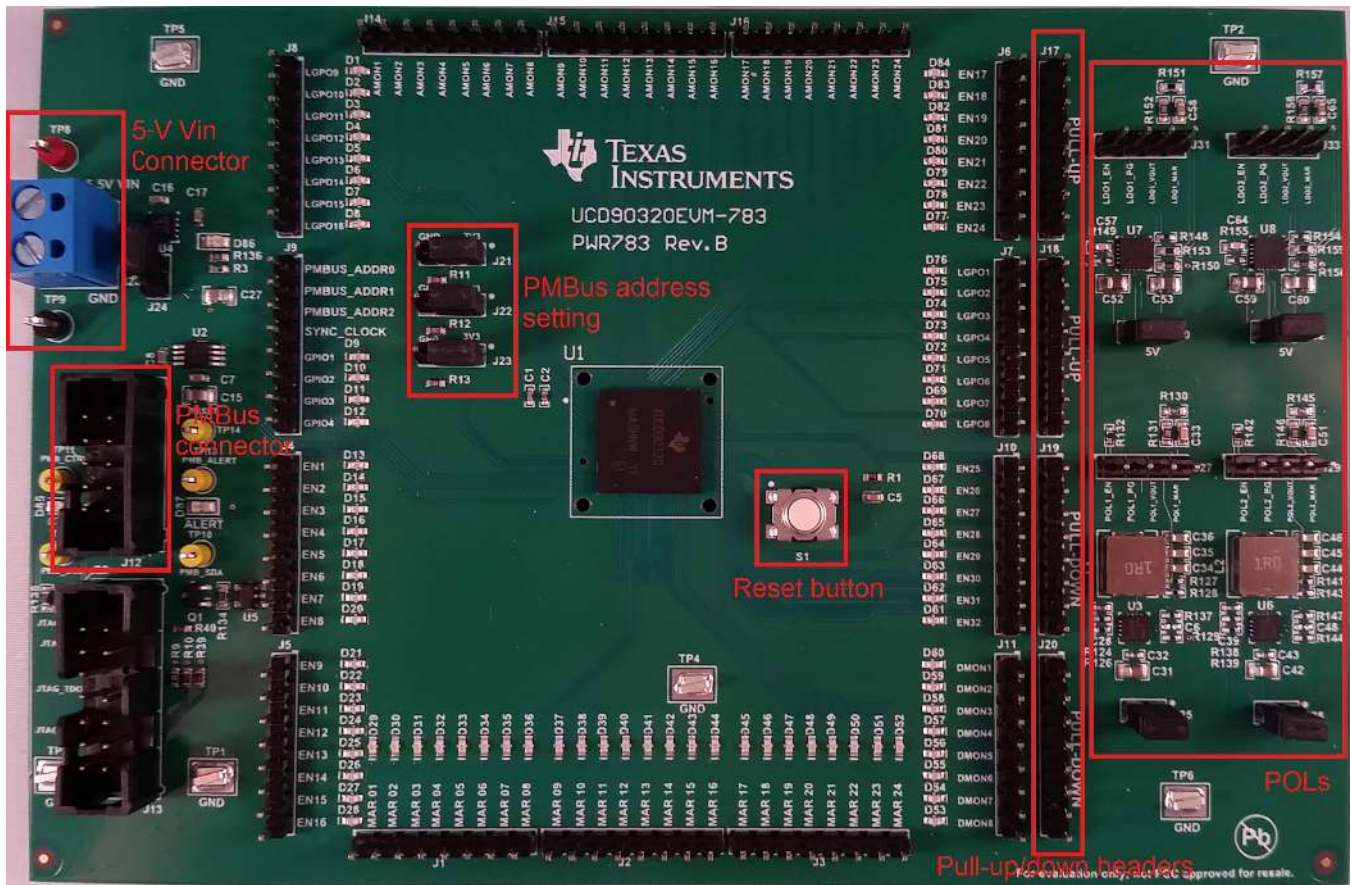
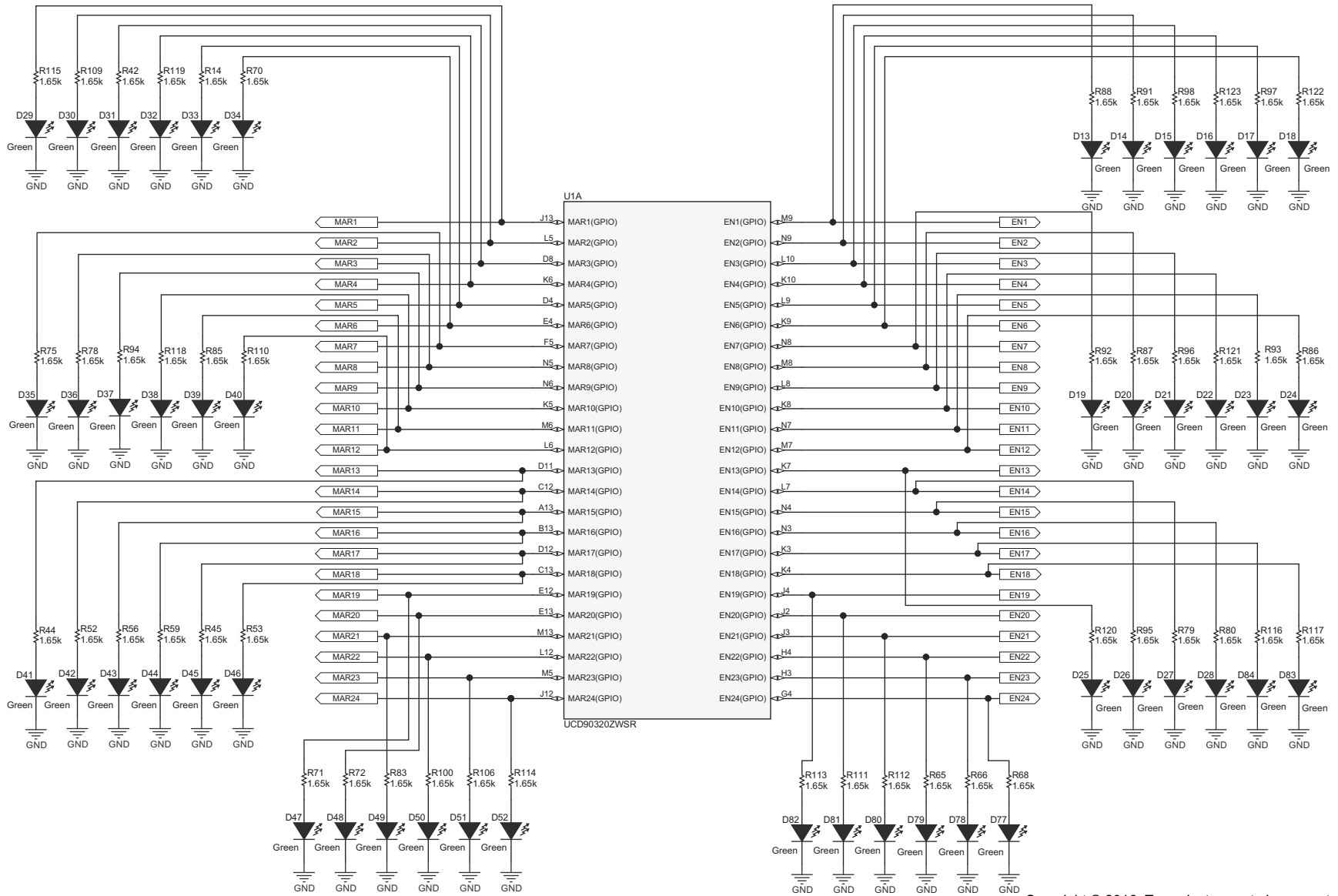
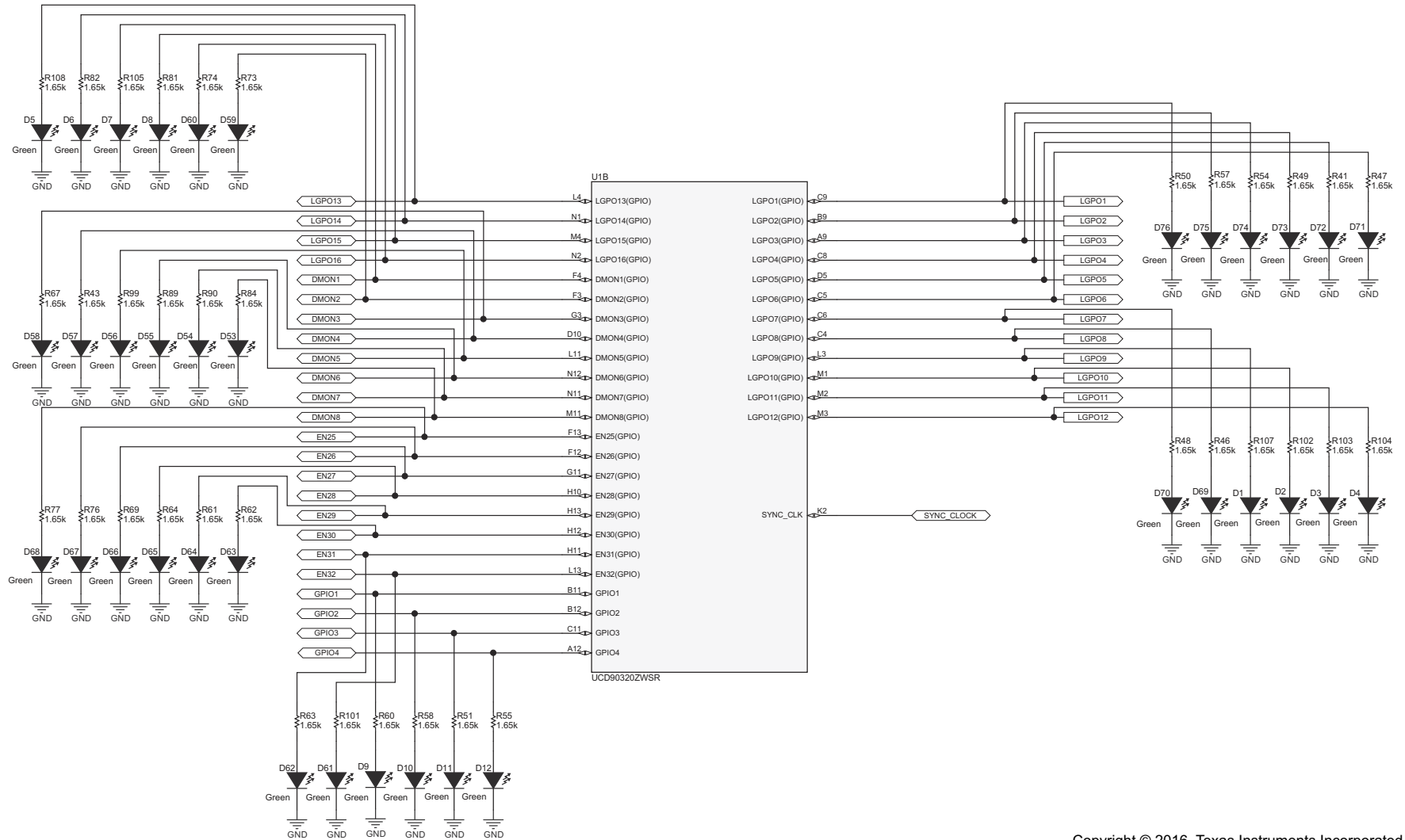

Figure 1. UCD90320EVM-783



Copyright © 2016, Texas Instruments Incorporated

Figure 2. UCD90320EVM-783 Schematic (1 of 6)



Copyright © 2016, Texas Instruments Incorporated

Figure 3. UCD90320EVM-783 Schematic (2 of 6)

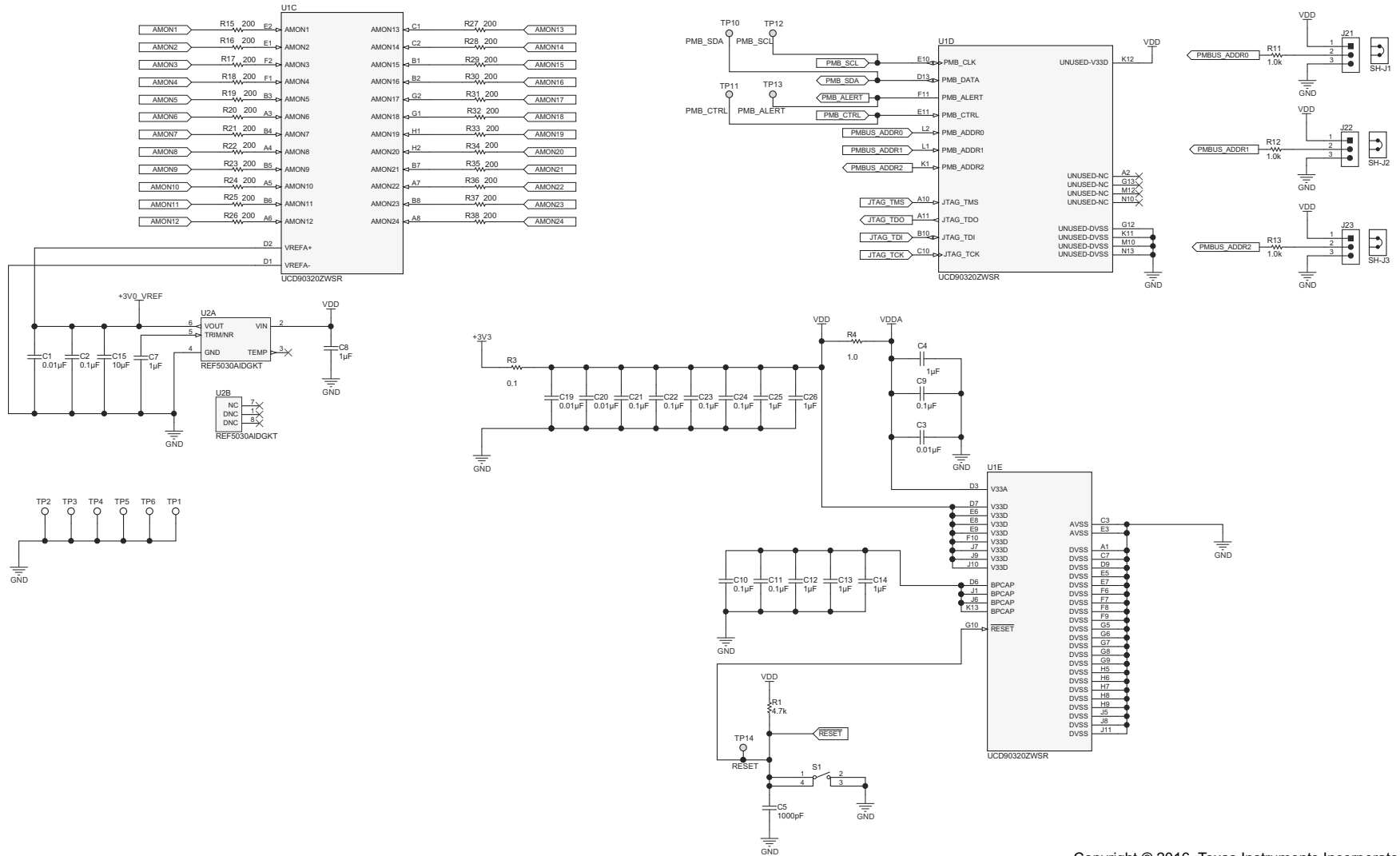

Copyright © 2016, Texas Instruments Incorporated

Figure 4. UCD90320EVM-783 Schematic (3 of 6)

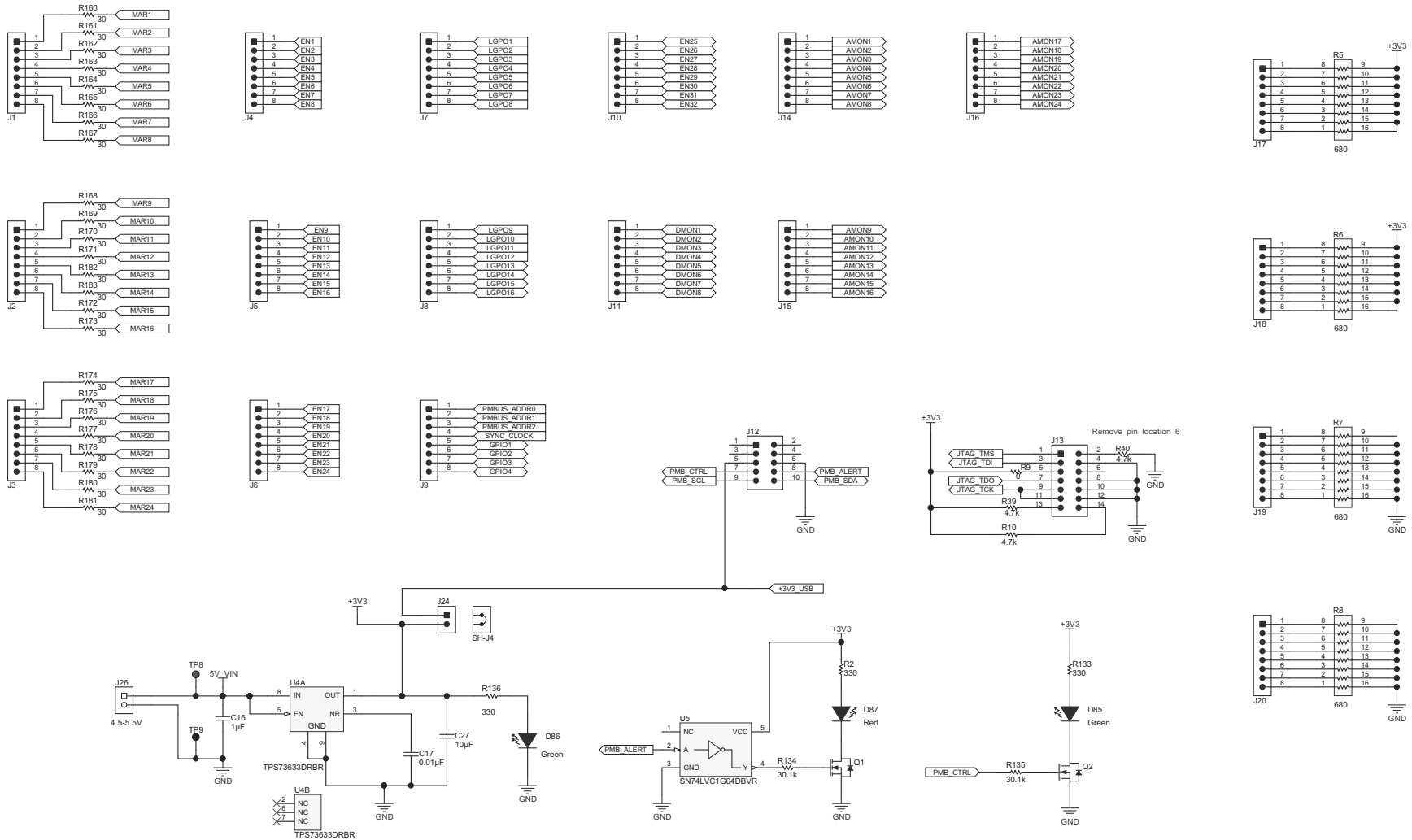

Copyright © 2016, Texas Instruments Incorporated

Figure 5. UCD90320EVM-783 Schematic (4 of 6)

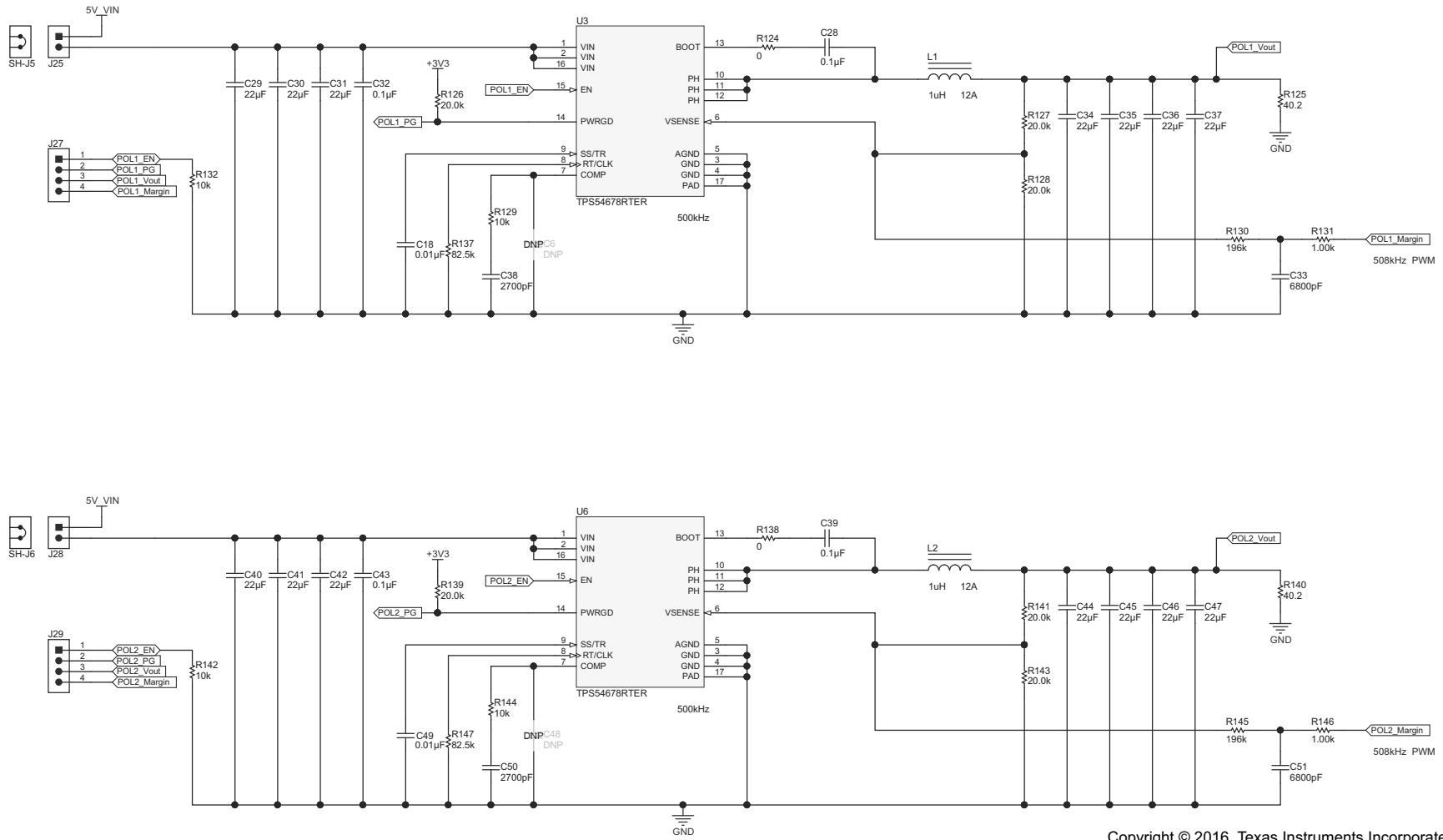

Copyright © 2016, Texas Instruments Incorporated

Figure 6. UCD90320EVM-783 Schematic (5 of 6)

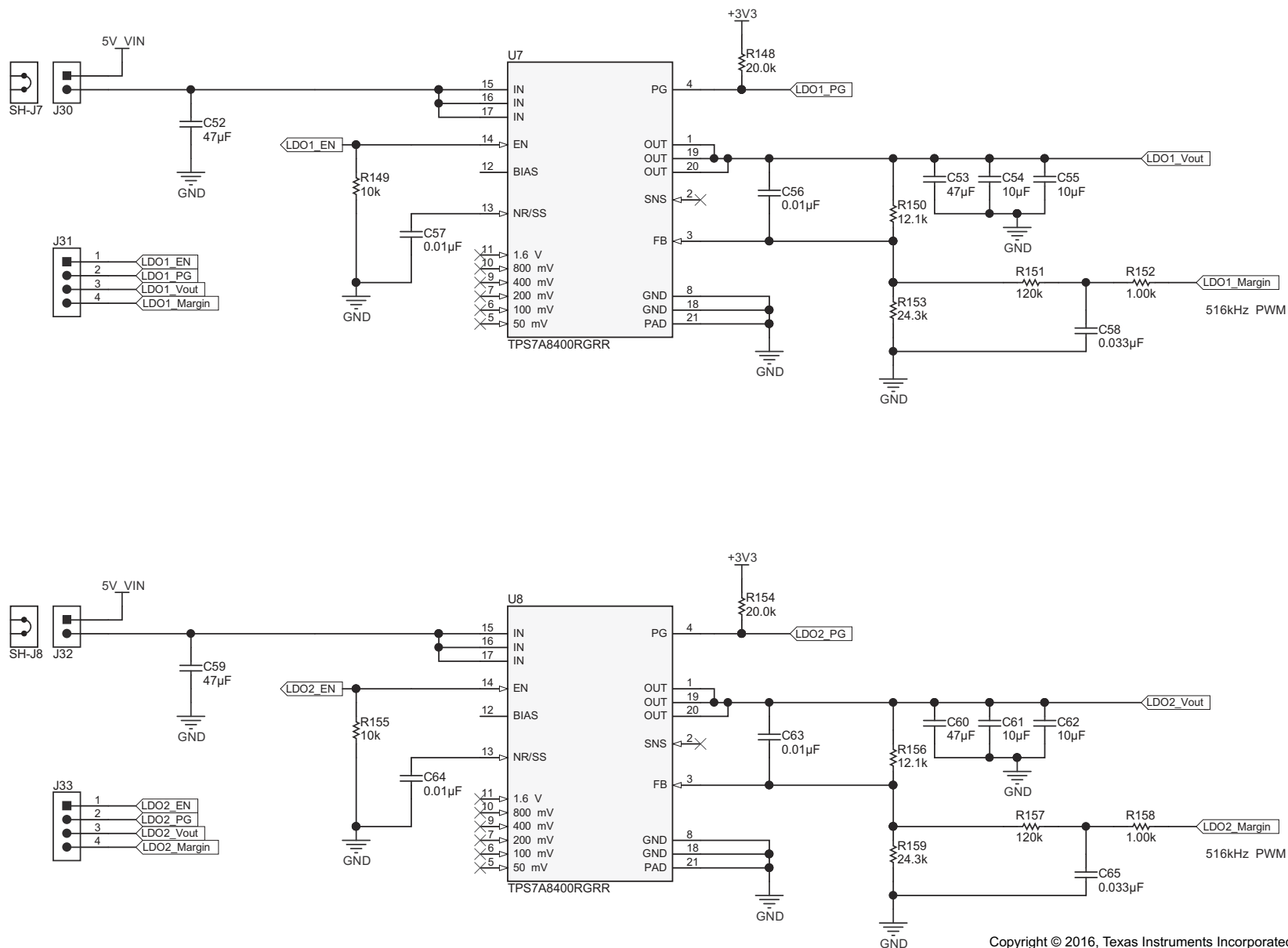

Copyright © 2016, Texas Instruments Incorporated

Figure 7. UCD90320EVM-783 Schematic (6 of 6)

5 Test Setup

5.1 Test Equipment

The following test equipment is recommended when using the EVM:

Voltage Source: One 5-volt power supply with at least 0.5A sourcing capability.

Multimeters: One volt-meter

Output Load: None

Oscilloscope: Optional

Fan: None

Recommended Wire Gauge: AWG24 or thicker

Recommended PC platform: Windows 7 64-bit with 8GB RAM

USB Interface Adapter EVM (USB-to-GPIO): HPA172

The latest version Fusion Digital Power Designer software can be downloaded at the following link to the Texas Instruments website:

http://focus.ti.com/docs/toolsw/folders/print/fusion_digital_power_designer.html

5.2 Recommended Test Setup

Figure 8 illustrates the recommended test setup.

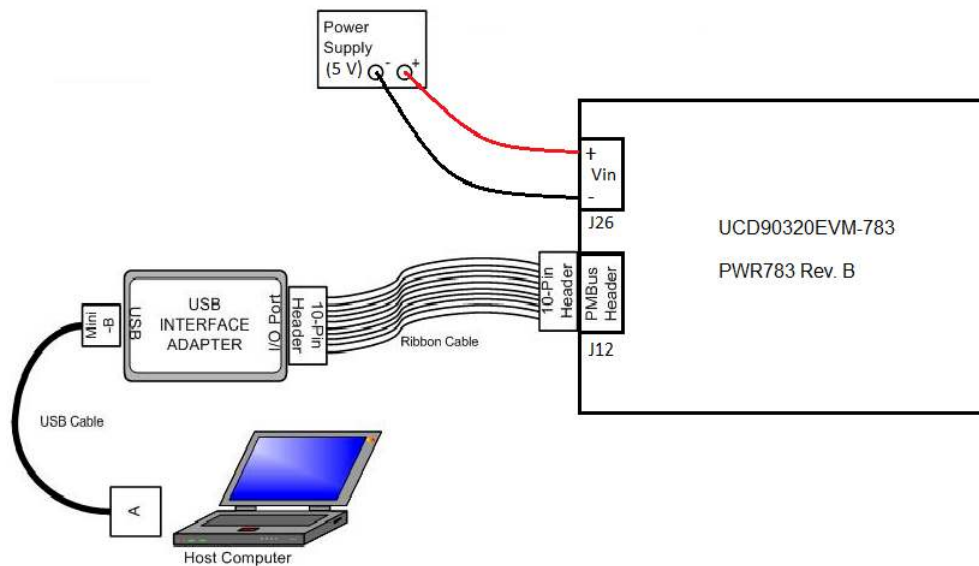

Figure 8. UCD90320EVM-783 Recommended Test Setup

5.3 List of Connectors and Functions

Table 2 lists the connectors and their functions.

Table 2. Connector Definitions

Connectors	Pins	Name	Description
J1	1	MAR01	Margin PWM output or GPIO
	2	MAR02	Margin PWM output or GPIO
	3	MAR03	Margin PWM output or GPIO
	4	MAR04	Margin PWM output or GPIO
	5	MAR05	Margin PWM output or GPIO
	6	MAR06	Margin PWM output or GPIO
	7	MAR07	Margin PWM output or GPIO
	8	MAR08	Margin PWM output or GPIO
J2	1	MAR09	Margin PWM output or GPIO
	2	MAR10	Margin PWM output or GPIO
	3	MAR11	Margin PWM output or GPIO
	4	MAR12	Margin PWM output or GPIO
	5	MAR13	Margin PWM output or GPIO
	6	MAR14	Margin PWM output or GPIO
	7	MAR15	Margin PWM output or GPIO
	8	MAR16	Margin PWM output or GPIO
J3	1	MAR17	Margin PWM output or GPIO
	2	MAR18	Margin PWM output or GPIO
	3	MAR19	Margin PWM output or GPIO
	4	MAR20	Margin PWM output or GPIO
	5	MAR21	Margin PWM output or GPIO
	6	MAR22	Margin PWM output or GPIO
	7	MAR23	Margin PWM output or GPIO
	8	MAR24	Margin PWM output or GPIO
J4	1	EN1	Rail enable output or GPIO
	2	EN2	Rail enable output or GPIO
	3	EN3	Rail enable output or GPIO
	4	EN4	Rail enable output or GPIO
	5	EN5	Rail enable output or GPIO
	6	EN6	Rail enable output or GPIO
	7	EN7	Rail enable output or GPIO
	8	EN8	Rail enable output or GPIO
J5	1	EN9	Rail enable output or GPIO
	2	EN10	Rail enable output or GPIO
	3	EN11	Rail enable output or GPIO
	4	EN12	Rail enable output or GPIO
	5	EN13	Rail enable output or GPIO
	6	EN14	Rail enable output or GPIO
	7	EN15	Rail enable output or GPIO
	8	EN16	Rail enable output or GPIO
J6	1	EN17	Rail enable output or GPIO
	2	EN18	Rail enable output or GPIO
	3	EN19	Rail enable output or GPIO
	4	EN20	Rail enable output or GPIO
	5	EN21	Rail enable output or GPIO
	6	EN22	Rail enable output or GPIO
	7	EN23	Rail enable output or GPIO
	8	EN24	Rail enable output or GPIO

Table 2. Connector Definitions (continued)

Connectors	Pins	Name	Description
J7	1	LGPO1	Logic GPO output or GPIO
	2	LGPO2	Logic GPO output or GPIO
	3	LGPO3	Logic GPO output or GPIO
	4	LGPO4	Logic GPO output or GPIO
	5	LGPO5	Logic GPO output or GPIO
	6	LGPO6	Logic GPO output or GPIO
	7	LGPO7	Logic GPO output or GPIO
	8	LGPO8	Logic GPO output or GPIO
J8	1	LGPO9	Logic GPO output or GPIO
	2	LGPO10	Logic GPO output or GPIO
	3	LGPO11	Logic GPO output or GPIO
	4	LGPO12	Logic GPO output or GPIO
	5	LGPO13	Logic GPO output or GPIO
	6	LGPO14	Logic GPO output or GPIO
	7	LGPO15	Logic GPO output or GPIO
	8	LGPO16	Logic GPO output or GPIO
J9	1	PMBUS_ADDR0	PMBus address pin
	2	PMBUS_ADDR1	PMBus address pin
	3	PMBUS_ADDR2	PMBus address pin
	4	SYNC_CLOCK	Sync Clock pin
	5	GPIO1	General Purpose I/O
	6	GPIO2	General Purpose I/O
	7	GPIO3	General Purpose I/O
	8	GPIO4	General Purpose I/O
J10	1	EN25	Rail enable output or GPIO
	2	EN26	Rail enable output or GPIO
	3	EN27	Rail enable output or GPIO
	4	EN28	Rail enable output or GPIO
	5	EN29	Rail enable output or GPIO
	6	EN30	Rail enable output or GPIO
	7	EN31	Rail enable output or GPIO
	8	EN32	Rail enable output or GPIO
J11	1	DMON1	Digital monitor input or GPIO
	2	DMON2	Digital monitor input or GPIO
	3	DMON3	Digital monitor input or GPIO
	4	DMON4	Digital monitor input or GPIO
	5	DMON5	Digital monitor input or GPIO
	6	DMON6	Digital monitor input or GPIO
	7	DMON7	Digital monitor input or GPIO
	8	DMON8	Digital monitor input or GPIO
J12	1		No connection
	2		No connection
	3		No connection
	4		No connection
	5	+3V3_USB	3.3-V power provided by USB interface adapter EVM
	6	GND	PMBus GND
	7	PMB_CTRL	PMBus CONTROL line
	8	PMB_ALERT	PMBus ALERT# line
	9	PMB_SCL	PMBus Clock
	10	PMB_SDA	PMBus Data
J13	1	JTAG_TMS	JTAG TMS

Table 2. Connector Definitions (continued)

Connectors	Pins	Name	Description
	2		JTAG nTRST (unused)
	3	JTAG_TDI	JTAG TDI
	4		JTAG TDIS (unused)
	5		JTAG VTRef (unused)
	6		JTAG KEY
	7	JTAG_TDO	JTAG TDO
	8	GND	JTAG GND
	9		JTAG RTCK (unused)
	10	GND	JTAG GND
	11	JTAG_TCK	JTAG TCK
	12	GND	JTAG GND
	13		JTAG EMU0 (unused)
	14		JTAG EMU1 (unused)
J14	1	AMON1	Analog monitor input
	2	AMON2	Analog monitor input
	3	AMON3	Analog monitor input
	4	AMON4	Analog monitor input
	5	AMON5	Analog monitor input
	6	AMON6	Analog monitor input
	7	AMON7	Analog monitor input
	8	AMON8	Analog monitor input
J15	1	AMON9	Analog monitor input
	2	AMON10	Analog monitor input
	3	AMON11	Analog monitor input
	4	AMON12	Analog monitor input
	5	AMON13	Analog monitor input
	6	AMON14	Analog monitor input
	7	AMON15	Analog monitor input
	8	AMON16	Analog monitor input
J16	1	AMON17	Analog monitor input
	2	AMON18	Analog monitor input
	3	AMON19	Analog monitor input
	4	AMON20	Analog monitor input
	5	AMON21	Analog monitor input
	6	AMON22	Analog monitor input
	7	AMON23	Analog monitor input
	8	AMON24	Analog monitor input
J17	1		Pull-up signal (can be used as GPI input)
	2		Pull-up signal (can be used as GPI input)
	3		Pull-up signal (can be used as GPI input)
	4		Pull-up signal (can be used as GPI input)
	5		Pull-up signal (can be used as GPI input)
	6		Pull-up signal (can be used as GPI input)
	7		Pull-up signal (can be used as GPI input)
	8		Pull-up signal (can be used as GPI input)
J18	1		Pull-up signal (can be used as GPI input)
	2		Pull-up signal (can be used as GPI input)
	3		Pull-up signal (can be used as GPI input)
	4		Pull-up signal (can be used as GPI input)
	5		Pull-up signal (can be used as GPI input)
	6		Pull-up signal (can be used as GPI input)

Table 2. Connector Definitions (continued)

Connectors	Pins	Name	Description
	7		Pull-up signal (can be used as GPI input)
	8		Pull-up signal (can be used as GPI input)
J19	1		Pull-down signal (can be used as GPI input)
	2		Pull-down signal (can be used as GPI input)
	3		Pull-down signal (can be used as GPI input)
	4		Pull-down signal (can be used as GPI input)
	5		Pull-down signal (can be used as GPI input)
	6		Pull-down signal (can be used as GPI input)
	7		Pull-down signal (can be used as GPI input)
	8		Pull-down signal (can be used as GPI input)
J20	1		Pull-down signal (can be used as GPI input)
	2		Pull-down signal (can be used as GPI input)
	3		Pull-down signal (can be used as GPI input)
	4		Pull-down signal (can be used as GPI input)
	5		Pull-down signal (can be used as GPI input)
	6		Pull-down signal (can be used as GPI input)
	7		Pull-down signal (can be used as GPI input)
	8		Pull-down signal (can be used as GPI input)
J21	1	VDD	VDD (connect to pin 2 to pullup)
	2		Floating pin connected to PMBUS_ADDR0 through 1-k Ω resistor
	3	GND	GND (connect to pin 2 to pulldown)
J22	1	VDD	VDD (connect to pin 2 to pullup)
	2		Floating pin connected to PMBUS_ADDR1 through 1-k Ω resistor
	3	GND	GND (connect to pin 2 to pulldown)
J23	1	VDD	VDD (connect to pin 2 to pullup)
	2		Floating pin connected to PMBUS_ADDR2 through 1-k Ω resistor
	3	GND	GND (connect to pin 2 to pulldown)
J24	1	+3V3_USB	3.3-V power provided by USB interface adapter EVM
	2	+3V3	3.3-V rail to power VDD. Install a shut jumper to this connector to supply VDD from USB interface adapter.
J25	1	5V	Connected to 5-V V_{IN}
	2		V_{IN} for POL. Connect to pin 1 to supply 5-V V_{IN} to POL.
J26	1	5V_VIN	5-V input power positive terminal
	2	GND	5-V input power negative terminal
J27	1	POL1_EN	Connect this pin to an EN pin to test enable function
	2	POL1_PG	Connect this pin to a DMON pin to test digital monitor function
	3	POL1_VOUT	Connect this pin to an AMON pin to test analog monitor function
	4	POL1_MAR	Connect this pin to a MAR pin to test margining function
J28	1	5V	Connected to 5-V V_{IN}
	2		V_{IN} for POL. Connect to pin 1 to supply 5-V V_{IN} to POL.
J29	1	POL2_EN	Connect this pin to an EN pin to test enable function
	2	POL2_PG	Connect this pin to a DMON pin to test digital monitor function
	3	POL2_VOUT	Connect this pin to an AMON pin to test analog monitor function
	4	POL2_MAR	Connect this pin to a MAR pin to test margining function
J30	1	5V	Connected to 5-V V_{IN}
	2		V_{IN} for POL. Connect to pin 1 to supply 5-V V_{IN} to POL.
J31	1	POL3_EN	Connect this pin to an EN pin to test enable function
	2	POL3_PG	Connect this pin to a DMON pin to test digital monitor function
	3	POL3_VOUT	Connect this pin to an AMON pin to test analog monitor function
	4	POL3_MAR	Connect this pin to a MAR pin to test margining function
J32	1	5V	Connected to 5-V V_{IN}
	2		V_{IN} for POL. Connect to pin 1 to supply 5-V V_{IN} to POL.

Table 2. Connector Definitions (continued)

Connectors	Pins	Name	Description
J33	1	POL4_EN	Connect this pin to an EN pin to test enable function
	2	POL4_PG	Connect this pin to a DMON pin to test digital monitor function
	3	POL4_VOUT	Connect this pin to an AMON pin to test analog monitor function
	4	POL4_MAR	Connect this pin to a MAR pin to test margining function

5.4 List of Test Points

Table 3 lists and describes the test points.

Table 3. Test Points Functions

Test Points	Name	Description
TP1	GND	Ground
TP2	GND	Ground
TP3	GND	Ground
TP4	GND	Ground
TP5	GND	Ground
TP6	GND	Ground
TP8	5V_VIN	5-V input power positive terminal
TP9	GND	Ground
TP10	PMB_SDA	PMBus Data
TP11	PMB_CTRL	PMBus CONTROL line
TP12	PMB_SCL	PMBus Clock
TP13	PMB_ALERT	PMBus ALERT# line
TP14	RESET	UCD90320 reset pin signal

6 Software Setup

Accessing the configuration of the UCD90320EVM-783, control and monitoring capabilities with the Fusion Digital Power Designer software tool requires a one-time software setup per host system.

6.1 Fusion Digital Power Designer Software (Fusion GUI) Installation

Place the *Fusion Digital Power Designer Software* (Fusion GUI) installer executable file in a known location on the host computer to be used for EVM configuration and test.

Double click the TI-Fusion-Digital-Power-Designer-2.0.xxx.exe file and proceed through the installation by accepting the installer prompts and the license agreement. Use the Fusion GUI installer's suggested default installation locations to complete the install.

When the Fusion GUI installation reaches the finished window, **uncheck** the Launch application check box and close the window.

7 Test Procedure

The UCD90320EVM-783_Default_Configuration.xml file is found on the TI website and is provided to allow the user to return the EVM to its originally-configured state. Open the Fusion GUI while the powered EVM is connected to the computer with the USB interface adapter. In the Fusion GUI interface, select **File** → **Import Project** and the *Project Open Wizard* window opens.

7.1 Voltage Monitoring Example

Connect the EVM as shown in Figure 8. Connect 5-V V_{IN} to J26. Open the *Fusion Digital Power Designer GUI* by navigating to the **Start** → **Texas Instruments Fusion Digital Power Designer** → **Fusion Digital Power Designer** (not the offline version which would have monitoring disabled).

All AMON and DMON pins are assigned to corresponding rails in the default configuration file. Connect a wire jumper from POL1_VOUT to the AMON1 pin. Connect a wire jumper from POL1_EN to a pull-up pin in J18. The output voltage of POL1 will be displayed as *Vout #1* voltage in the **Fusion GUI** → **Monitor** page. Note that floating AMON pins give non-zero readings, which is an expected behavior.

7.2 Rail Enable Example

In the default configuration file, all EN pins are assigned to corresponding rails, and all rails are controlled by the CONTROL pin. The pin assignments are shown in the **Fusion GUI** → **Configure page** → **Hardware Configuration** tab. The CONTROL pin status can be controlled in the **Fusion GUI** → **Monitor** page. Turn on the CONTROL Line in the *Monitor* page. Observe that all LEDs attached to EN pins are lit.

7.3 Fault Log Example (Including Blackbox Log)

In the *Status* page, click the **Clear Faults** button, the **Clear Logged Faults** button, and the **Clear Blackbox Log** button to clear all previous faults. In **Configure page** → **Global Configuration** tab → **Set/Sync Device Clock** window, click **Set Device Clock to Local PC Time** button to update device run time clock.

With the CONTROL line being asserted, disconnect the jumper wire from the POL1_EN pin, which disables the POL1 output. Since the CONTROL line is asserted, and Rail #1 is previously in *Power Good* condition, the unexpected POL1 output drop will cause a V_{OUT} UV fault. In the **Status page** → **Status Registers** tab, observe that the V_{OUT} UV Fault of Rail #1 is raised. In the *Logged Faults* tab, observe that the V_{OUT} UV Fault of Rail #1 is also raised. In the *Blackbox Info* tab, click the **Refresh Blackbox Log** button. Observe that all the fault information and status of all the GPI, GPO, and rails when the fault occurred were recorded in the *Blackbox Log*.

7.4 Command GPO Example

In the default configuration file, the GPIO3-4 pins are configured as command GPO. In the **Configure page** → **Hardware Configuration** tab, change the *Command GPO* states and then click the **Write to Hardware** button. Observe the LED of the corresponding GPIO pin changes state.

7.5 GPI and Logic GPO Example

In the default configuration file, the GPIO1 pin is configured as GPI pin with GPI fault enabled. Each of the 16 LGPO pins is configured to follow the GPI input with 960-ms time delay. The pin assignments are shown in **Configure page** → **Hardware Configuration** tab.

Connect a jumper wire from a pull-up pin in J17 or J18 to the GPI pin. Observe that the LEDs of the 16 LGPO pins are lit after 960 ms. Also observe that the corresponding GPI Fault is logged in the *Status* page. Then disconnect the logic input signal from the GPI pin. Observe that the LEDs of the LGPO pins are out after 960 ms.

7.6 Margin Example

In the default configuration file, all 24 analog rails are configured with the margining function. The pin assignments are shown in **Configure page** → **Hardware Configuration** tab. Connect POL1 output voltage (J27-POL1_VOUT) to AMON1 pin using a jumper wire. Then connect the margin input of POL1 (J27-POL1_MAR) to the MAR1 pin. Also, connect the enable pin of POL1 (J27-POL1_EN) to EN1.

In **Fusion GUI** → **Monitor page**, turn on the CONTROL line. Observe that the EN1 pin's LED is lit, and the on-board POL is enabled. The POL's output voltage is monitored in the Monitor page, which should be at 1.2 V. In **Fusion GUI** → **Monitor page**, click to change margin status to Low. Observe that the POL output voltage is regulated at Margin Low level defined in **Configure page** → **Vout Config** tab. Then click to change margin status to High. Observe that the POL output voltage is regulated at Margin High level.

7.7 Cascading Example

7.7.1 Sync Clock

Sync Clock can synchronize multiple UCD90320 devices such that they respond to the same GPI event synchronously, and the same GPI event has the same time stamp in all synchronized UCD90320 devices. The *Sync Clock I/O* pin is located in J9. Implementing the *Sync Clock* feature requires two or more UCD90320EVM-783 boards.

In **Fusion GUI** → **Configure page** → **Global Configuration tab** → **Misc Config**, configure one EVM board as *Sync Clock* master, and all other boards as slaves. Connect the multiple EVM boards to the same ground. Connect all *Sync Clock* pins to the same node. Observe that the synchronized UCD90320 devices respond to the same GPI event synchronously.

When the *Sync Clock* pin is not used, configure the UCD90320 device as *Sync Clock* master.

7.7.2 Fault Pin

Multiple UCD90320 devices can be acknowledged of the same rail fault and react accordingly, even if the rail is monitored by only one UCD90320 device. This is achieved with the *Fault Pin* feature.

In each UCD90320 device, up to 4 GPI pins can be configured as *Fault Pins*. Each *Fault Pin* is connected to a *Fault Bus*. Each *Fault Bus* should be pulled up to 3.3 V by a 10-k Ω resistor. When there is no fault on a *Fault Bus*, the *Fault Pins* are GPI pins and listen to the *Fault Bus*. When a rail fault is detected by a UCD90320 device, the corresponding *Fault Pin* is turned into active driven low state, pulling down the *Fault Bus* and informing all other UCD90320 devices of the corresponding fault.

In the default configuration file, the GPIO2 pin is configured as a *Fault Pin*. Continuing the previous example, where CONTROL line is asserted, POL1_EN is connected to EN1, and POL1_VOUT is connected to AMON1. Connect GPIO2 (*Fault Pin*) to a pull-up pin in J17 or J18. Then, disconnect the POL1_VOUT pin from AMON1, observe that the LED of GPIO2 is out due to Rail #1 V_{OUT} UV fault. The *Fault Pin* configuration is in **Fusion GUI** → **Configure page** → **Global Configuration tab** → **Fault Pin Config**. Only the faults on selected rails (pages) will trigger the *Fault Pin* to pulldown.

Reconnect POL1_VOUT to AMON1 so that the *Fault Pin* is no longer held low by the UCD90320 device. Next, disconnect GPIO2 from the pull-up signal. This simulates the condition that the *Fault Bus* is pulled down by another UCD90320 device. Observe that a GPI2 fault is logged in **Fusion GUI** → **Status page** → **Logged Faults tab** → **Logged Faults Detail**. This GPI fault can be configured to trigger rail shut down. The fault response of each rail to GPI faults can be configured in the **Fusion GUI** → **Configure page** → **Rail Config tab** → **GPI Fault Responses** window.

The *Fault Pin* feature and the *Sync Clock* feature can work together to achieve better synchronized fault response performance.

8 EVM Assembly Drawing and PCB Layout

The EVM assembly drawing and PCB layout images are shown in Figure 9 through Figure 22.

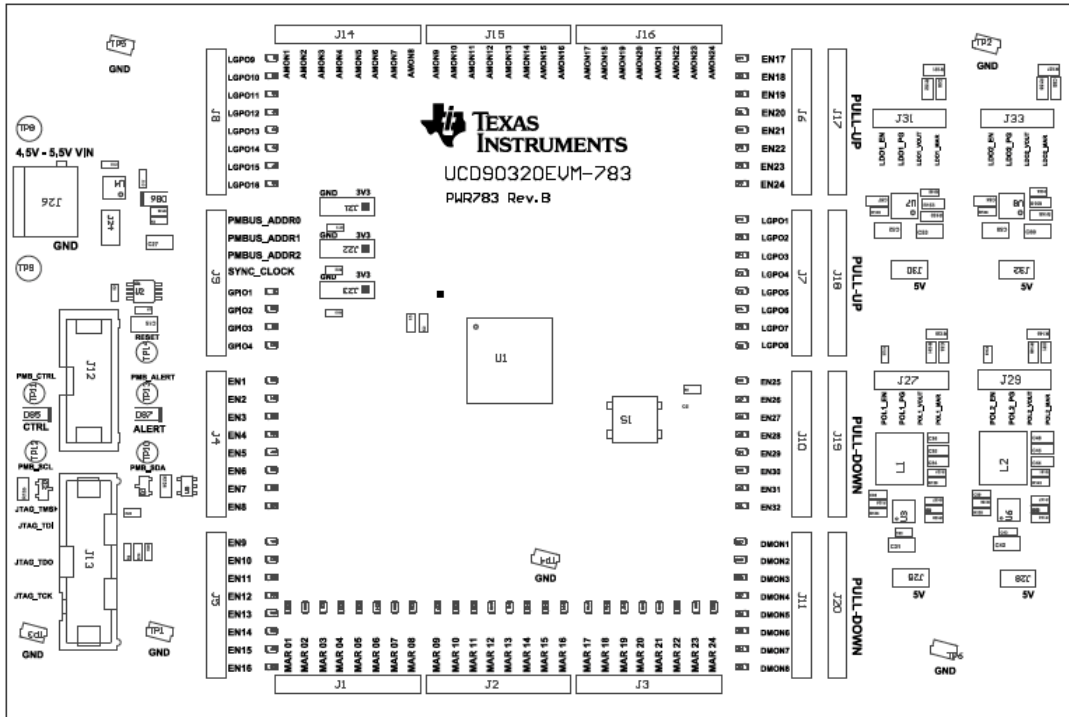

Figure 9. Top Assembly Drawing

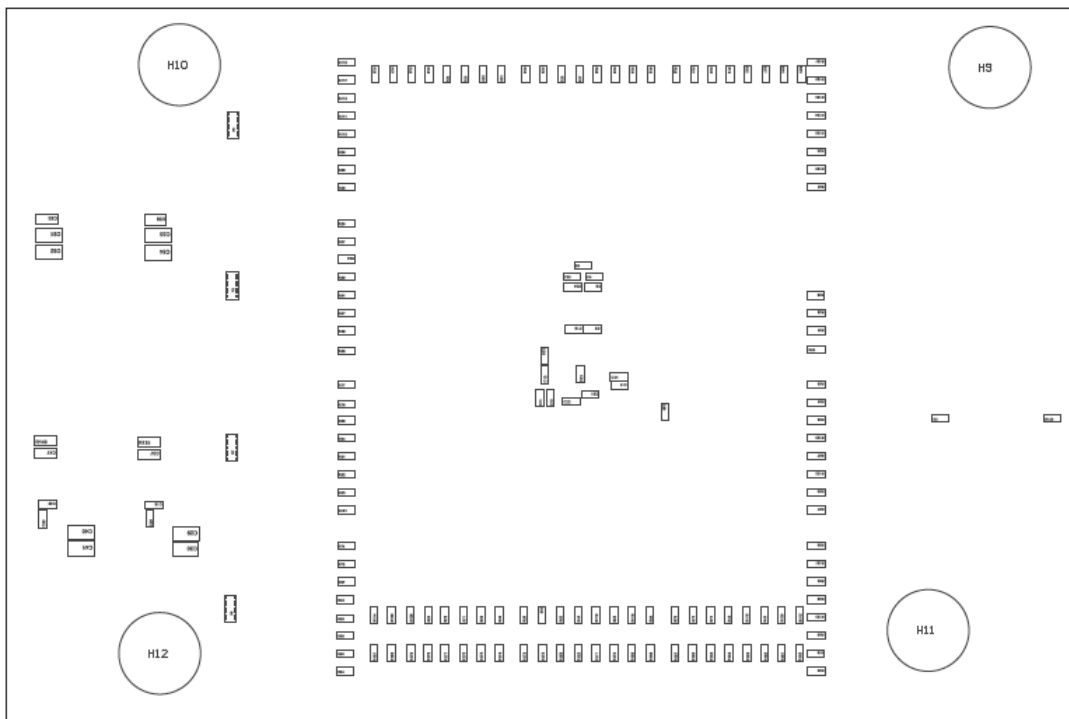

Figure 10. Bottom Assembly Drawing

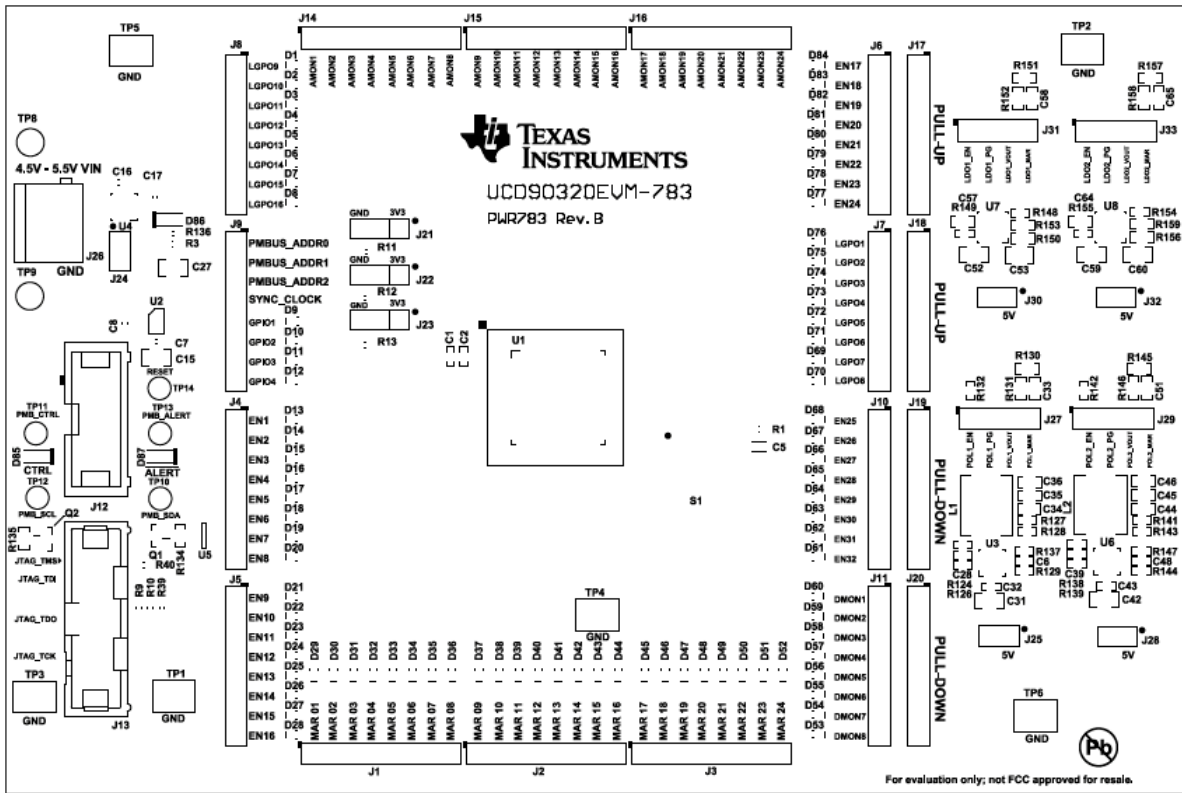

Figure 11. Top Overlay

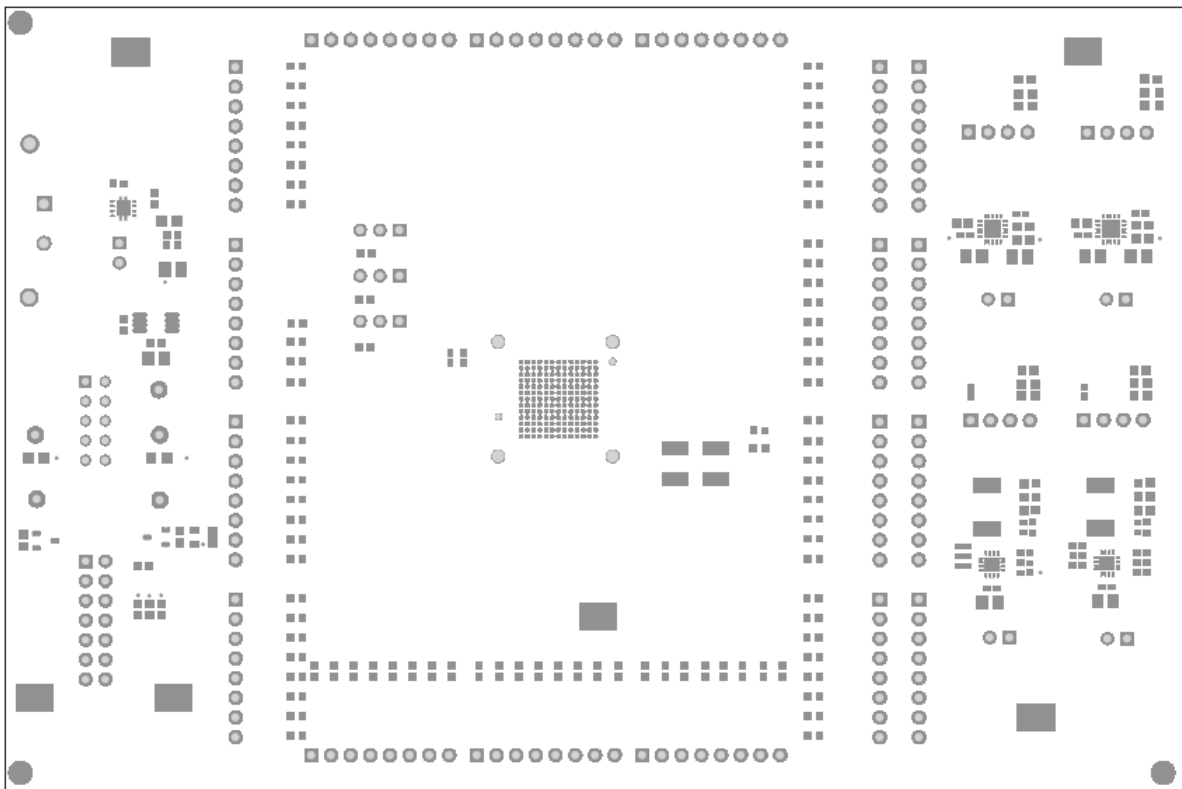

Figure 12. Top Solder Mask

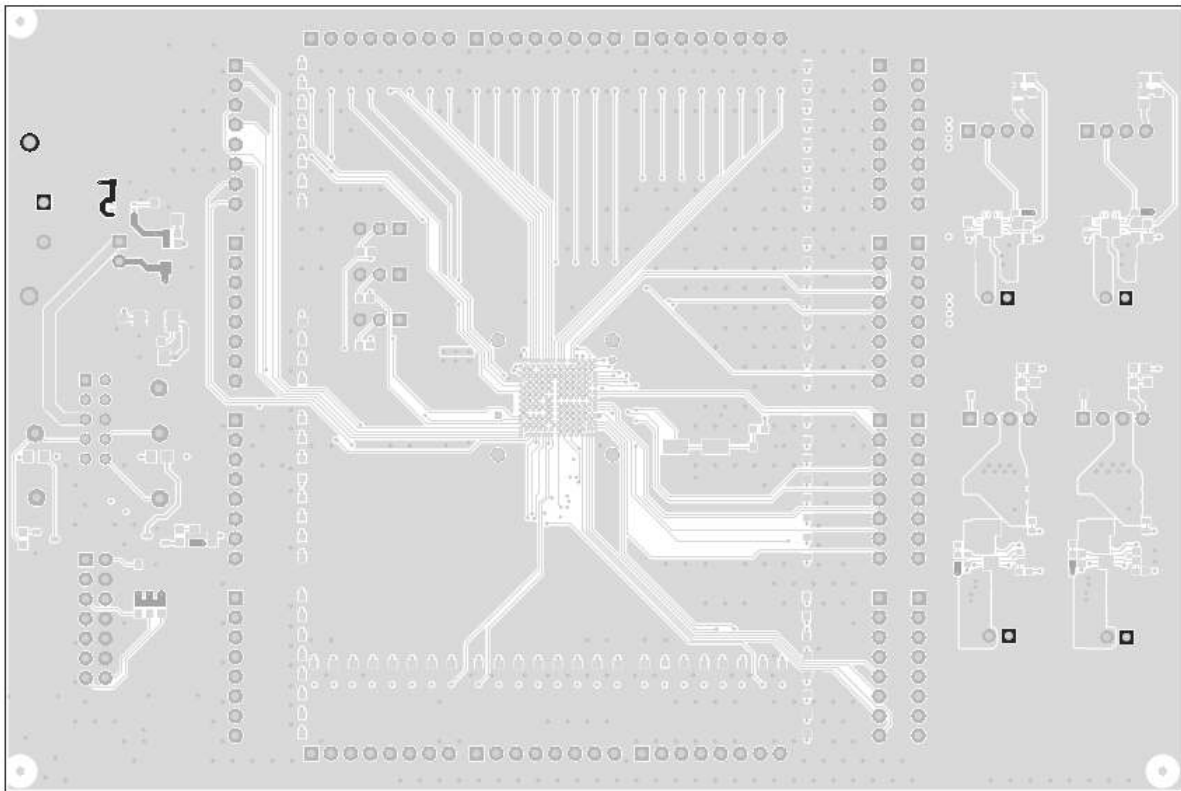

Figure 13. Top Layer

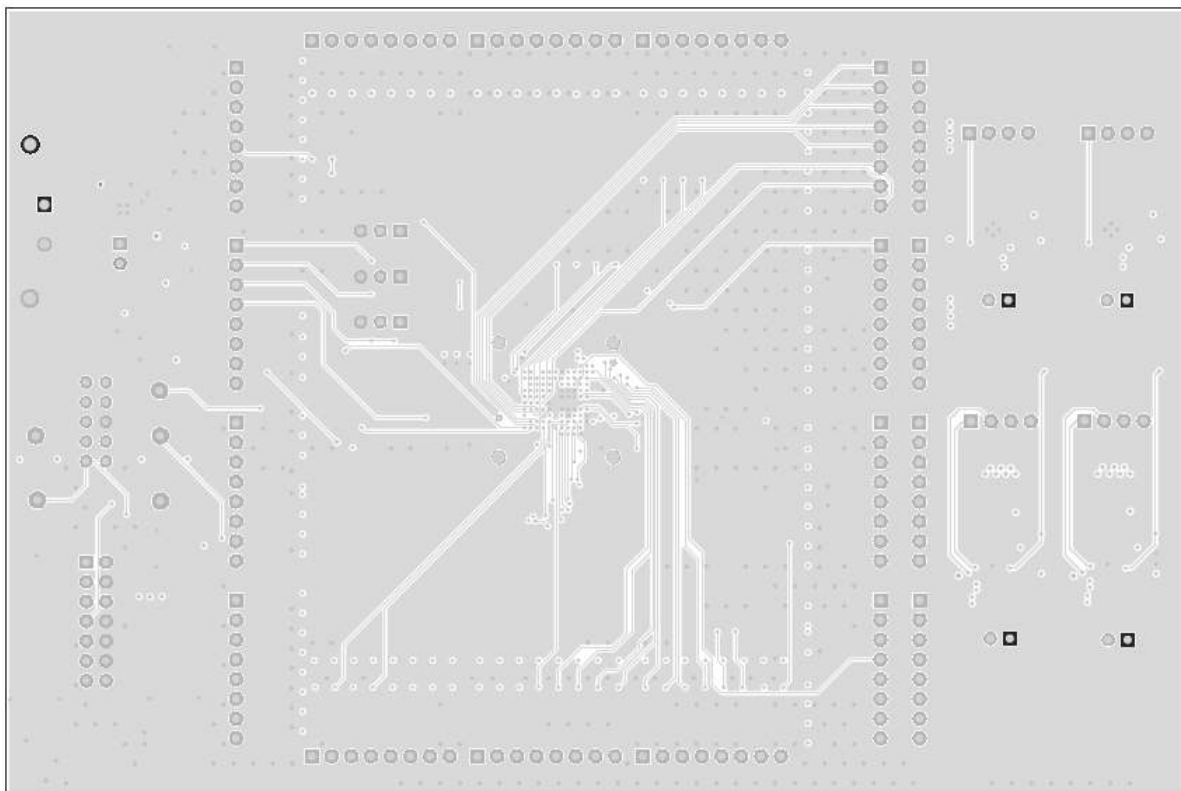

Figure 14. Mid Layer 1

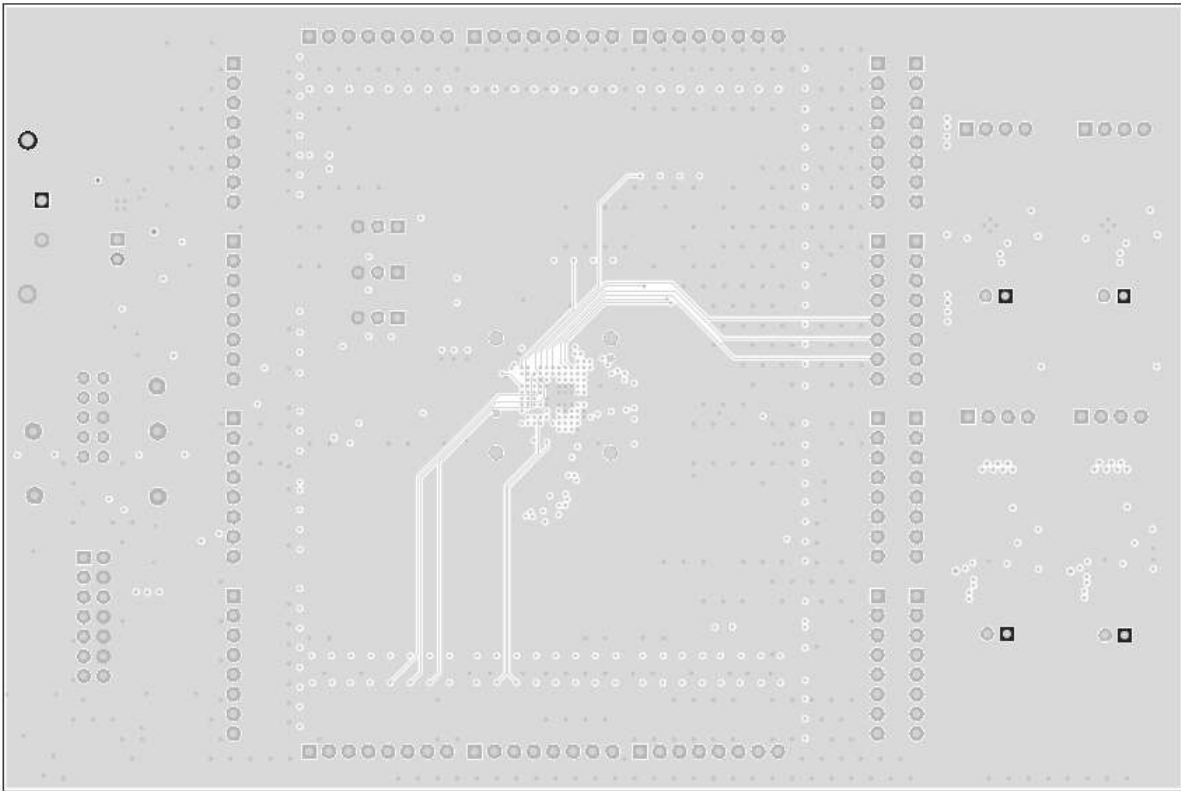

Figure 15. Mid Layer 2

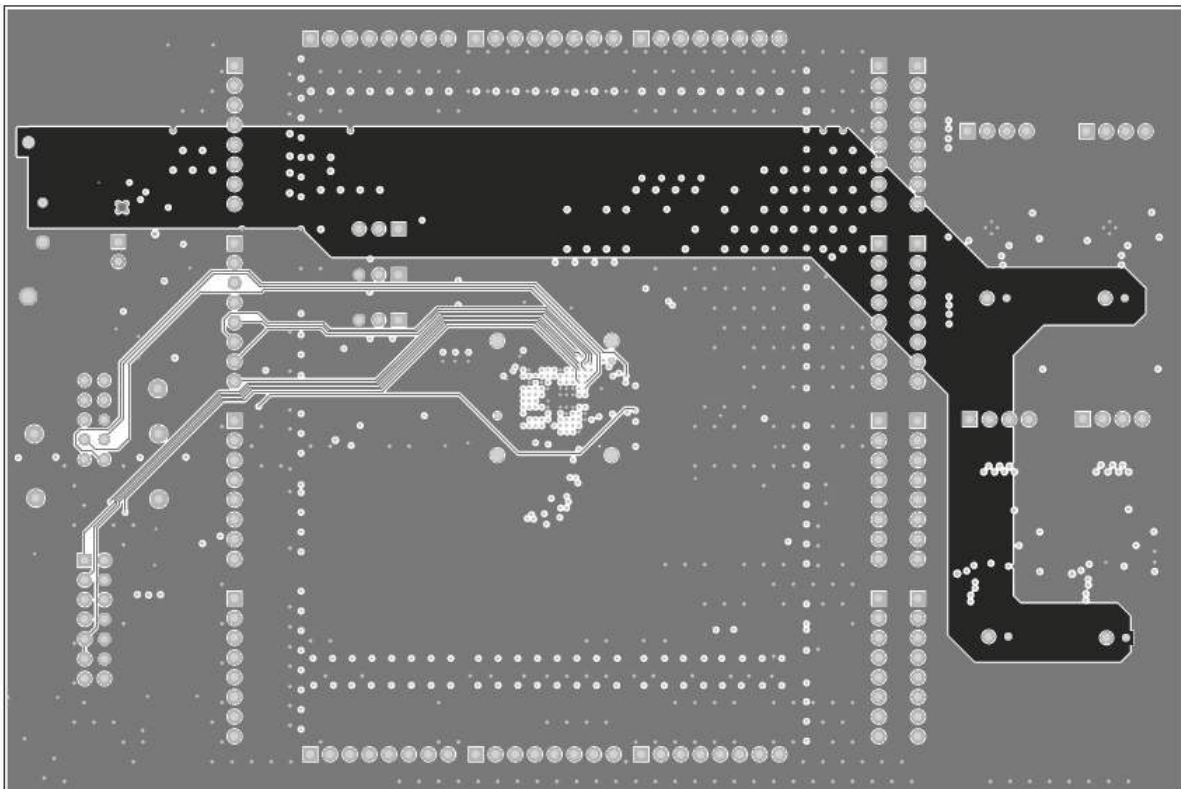

Figure 16. Mid Layer 3

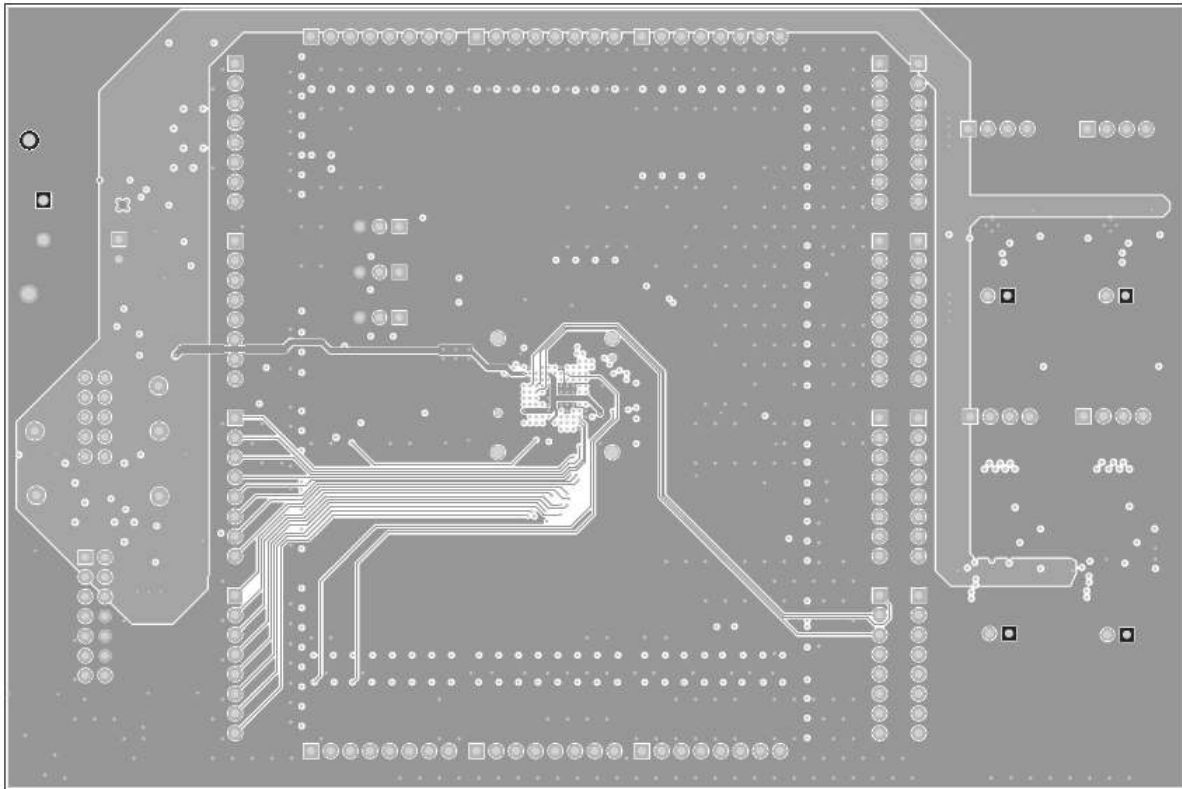

Figure 17. Mid Layer 4

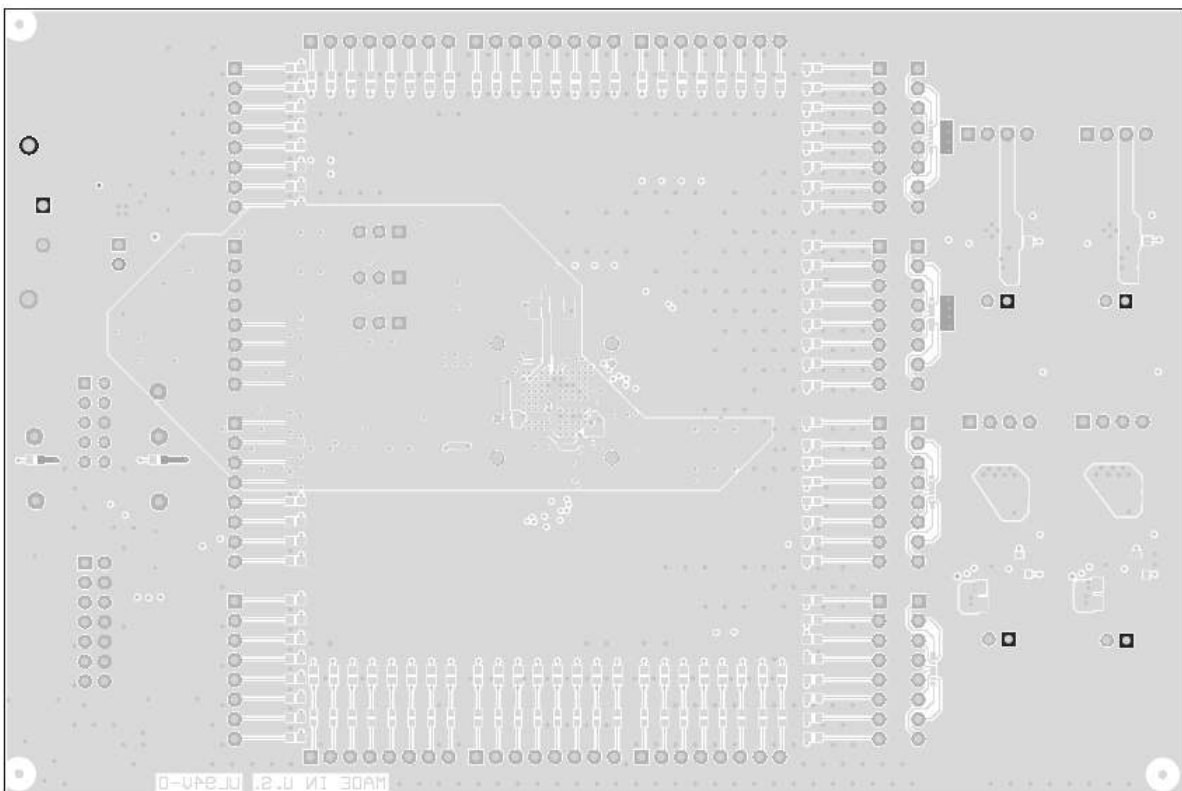

Figure 18. Bottom Layer

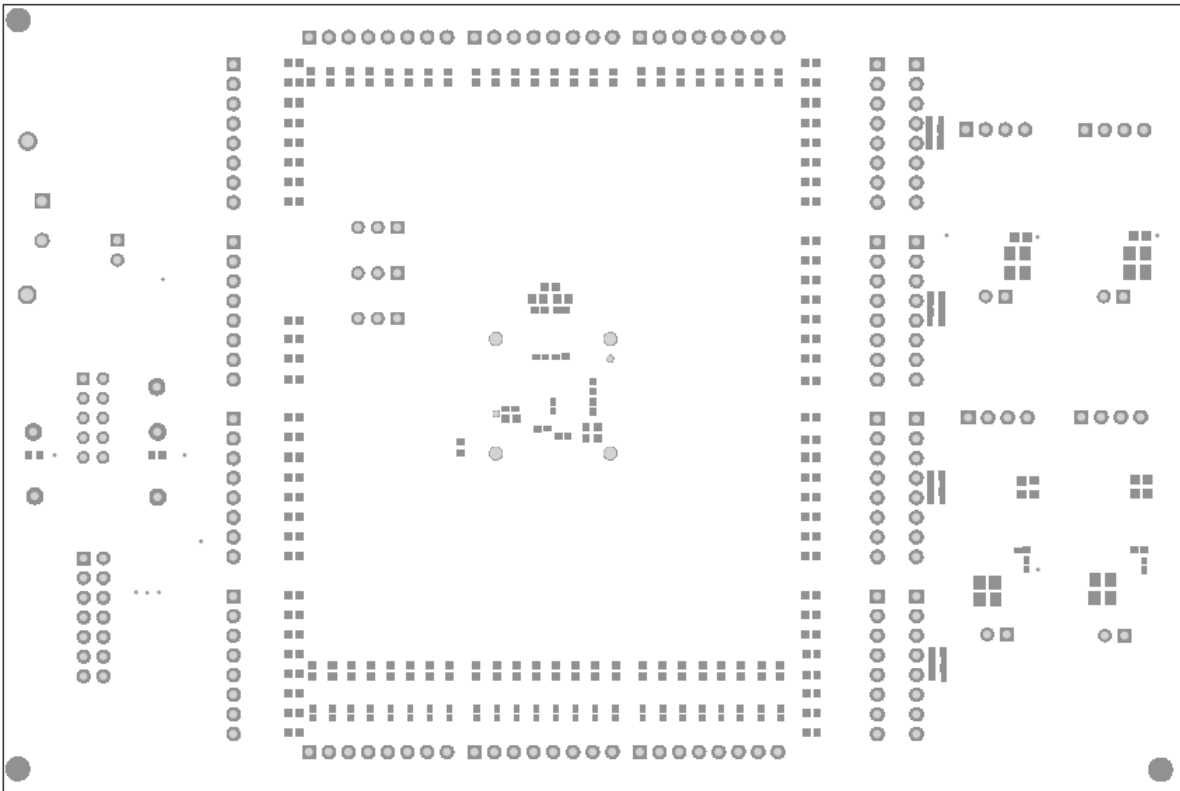

Figure 19. Bottom Solder Mask

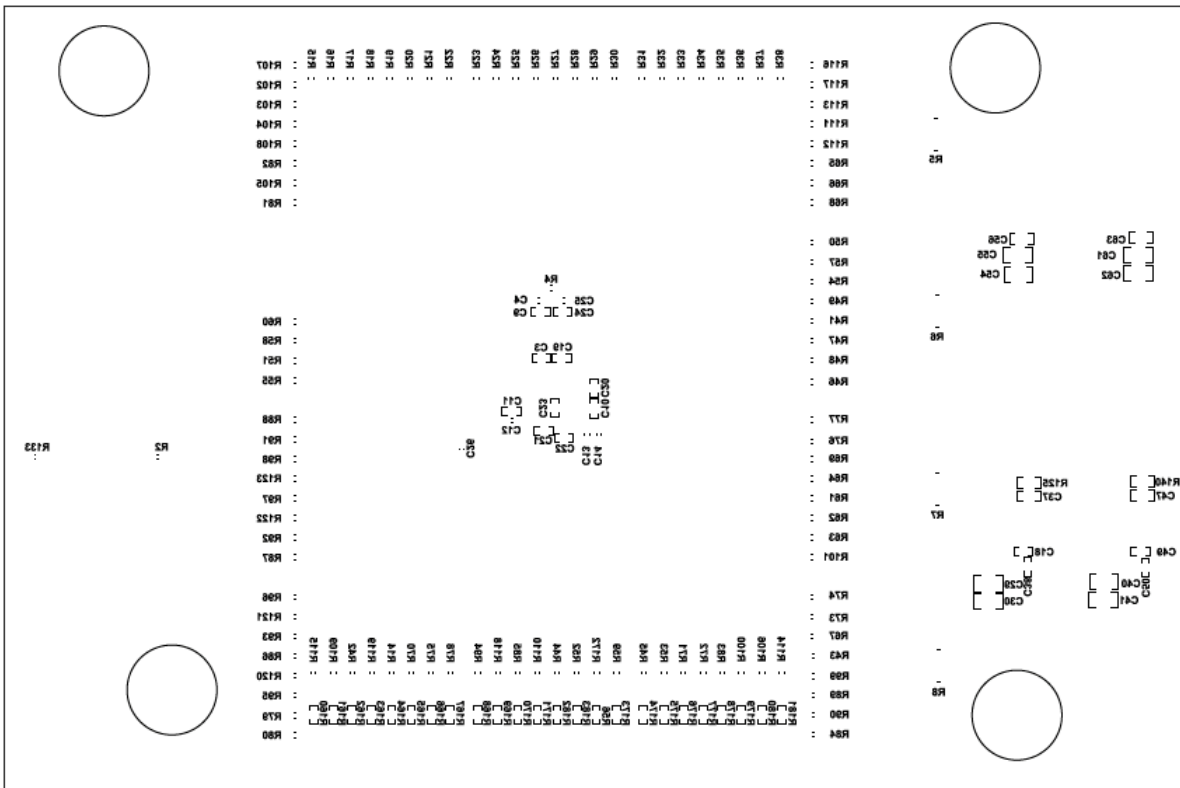

Figure 20. Bottom Overlay

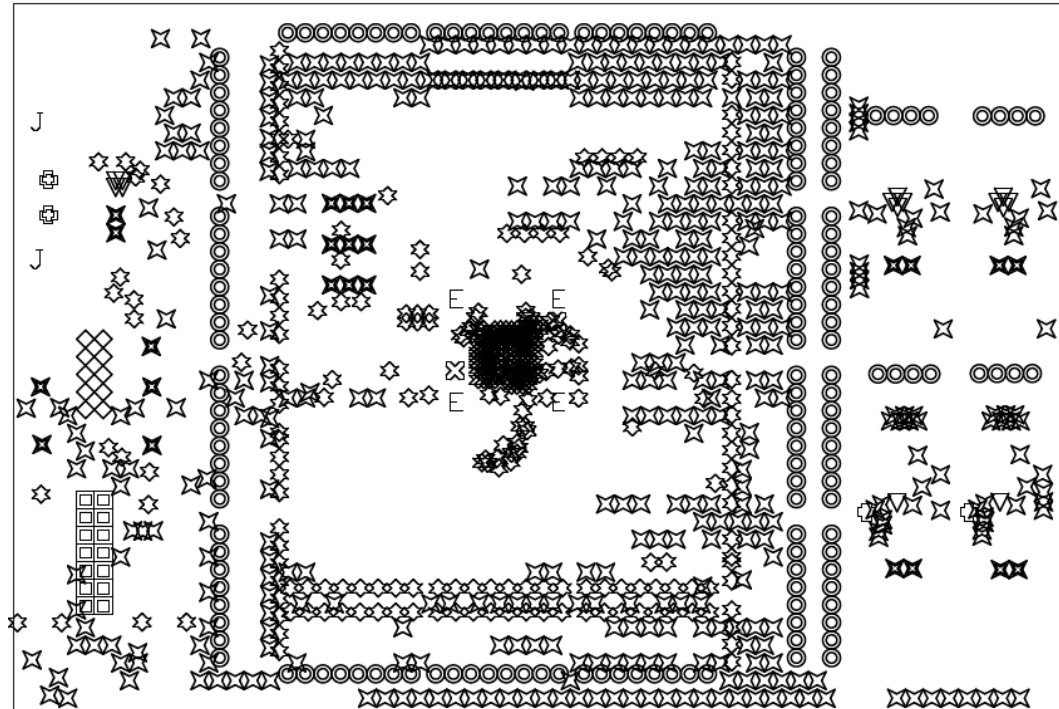

Figure 21. Drill Drawing

Symbol	Hit Count	Finished Hole Size	Plated	Hole Type
⊙	2	12.00mil (0.305mm)	PTH	Round
⊗	2	31.10mil (0.790mm)	NPTH	Round
⊖	2	49.21mil (1.250mm)	PTH	Round
⋈	2	63.00mil (1.600mm)	PTH	Round
⊕	4	62.60mil (1.590mm)	NPTH	Round
⊖	10	35.43mil (0.900mm)	PTH	Round
∇	14	7.87mil (0.200mm)	PTH	Round
⊞	14	37.00mil (0.940mm)	PTH	Round
⊗	24	40.00mil (1.016mm)	PTH	Round
⊖	160	39.37mil (1.000mm)	PTH	Round
⊖	307	8.00mil (0.203mm)	PTH	Round
⊗	480	10.00mil (0.254mm)	PTH	Round
	1021 Total			

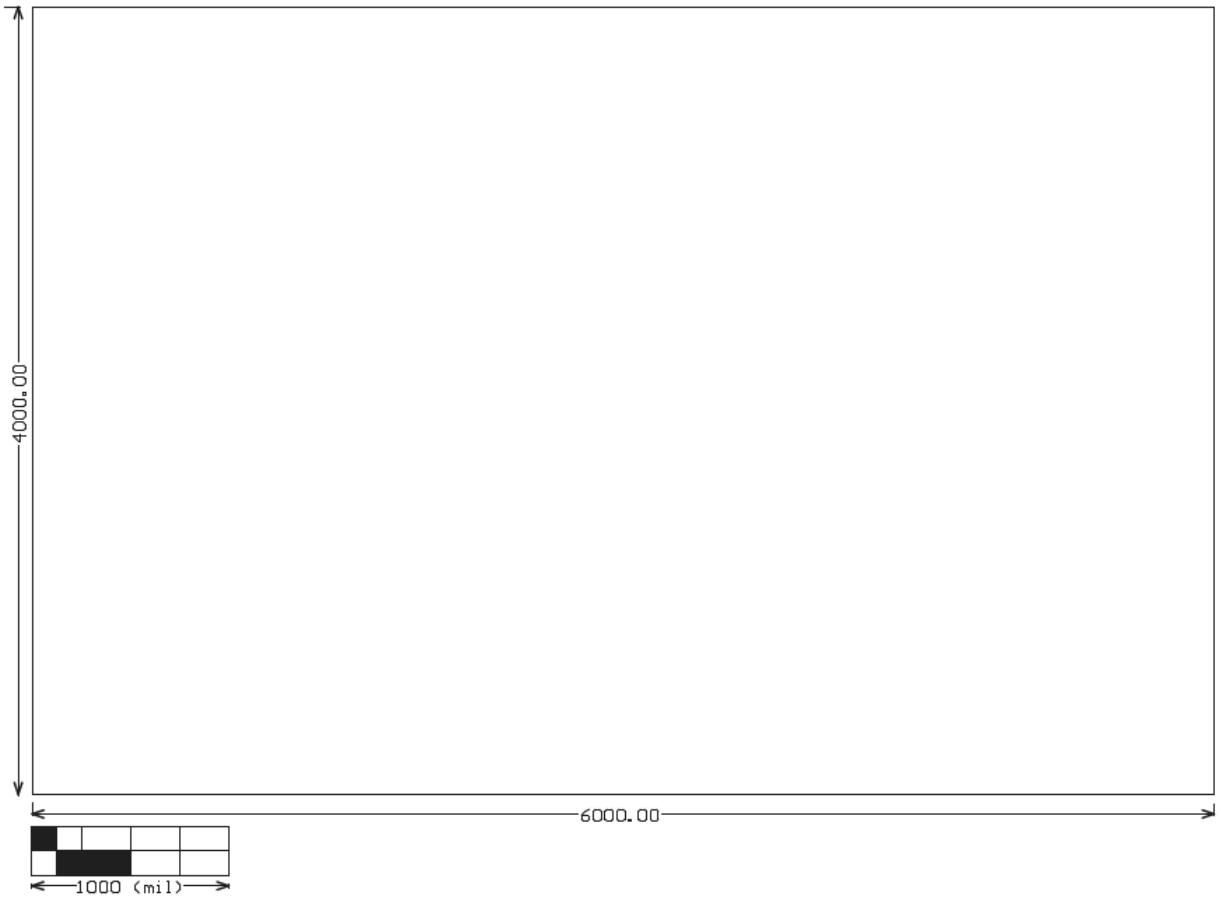

Figure 22. Board Dimensions

9 Bill of Material

Table 4 lists the EVM BOM.

Table 4. UCD90320EVM-783 BOM

Designator	Qty	Value	Description	Package Reference	Part Number	Manufacturer	Alternate Part Number	Alternate Manufacturer
C1, C3, C18, C19, C20, C49	6	0.01uF	CAP, CERM, 0.01 μ F, 16 V, +/- 10%, X7R, 0402	0402	C1005X7R1C103K	TDK		
C2, C9, C10, C11, C21, C22, C23, C24	8	0.1uF	CAP, CERM, 0.1 μ F, 6.3 V, +/- 10%, X5R, 0402	0402	C1005X5R0J104K	TDK		
C4, C7, C8, C12, C13, C14, C16, C25, C26	9	1uF	CAP, CERM, 1 μ F, 25 V, +/- 10%, X5R, 0603	0603	C1608X5R1E105K080AC	TDK		
C5	1	1000pF	CAP, CERM, 1000pF, 50V, +/-5%, X7R, 0603	0603	C0603C102J5RACTU	Kemet	-	-
C15, C27	2	10uF	CAP, CERM, 10 μ F, 6.3 V, +/- 10%, X6S, 0805	0805	GRM219C80J106KE39D	Murata		
C17	1	0.01uF	CAP, CERM, 0.01 μ F, 50 V, +/- 5%, X7R, 0603	0603	C0603C103J5RACTU	Kemet		
C28, C32, C39, C43	4	0.1uF	CAP, CERM, 0.1 μ F, 16 V, +/- 10%, X5R, 0402	0402	GRM155R61C104KA88D	Murata		
C29, C30, C31, C40, C41, C42	6	22uF	CAP, CERM, 22 μ F, 6.3 V, +/- 20%, X5R, 0805	0805	GRM21BR60J226ME39L	Murata		
C33, C51	2	6800pF	CAP, CERM, 6800 pF, 100 V, +/- 10%, X7R, 0603	0603	06031C682KAT2A	AVX		
C34, C35, C36, C37, C44, C45, C46, C47	8	22uF	CAP, CERM, 22 μ F, 6.3 V, +/- 20%, X5R, 0603	0603	C1608X5R0J226M080AC	TDK		
C38, C50	2	2700pF	CAP, CERM, 2700 pF, 50 V, +/- 10%, X7R, 0402	0402	GRM155R71H272KA01D	Murata		
C52, C53, C59, C60	4	47uF	CAP, CERM, 47 μ F, 4 V, +/- 20%, X5R, 0805	0805	GRM219R60G476ME44D	Murata		
C54, C55, C61, C62	4	10uF	CAP, CERM, 10 μ F, 16 V, +/- 10%, X5R, 0805	0805	GRM21BR61C106KE15L	Murata		
C56, C57, C63, C64	4	0.01uF	CAP, CERM, 0.01 μ F, 50 V, +/- 10%, X7R, 0603	0603	GRM188R71H103KA01D	Murata		
C58, C65	2	0.033uF	CAP, CERM, 0.033 μ F, 50 V, +/- 5%, X7R, 0603	0603	06035C333JAT2A	AVX		
D1, D2, D3, D4, D5, D6, D7, D8, D9, D10, D11, D12, D13, D14, D15, D16, D17, D18, D19, D20, D21, D22, D23, D24, D25, D26, D27, D28, D29, D30, D31, D32, D33, D34, D35, D36, D37, D38, D39, D40, D41, D42, D43, D44, D45, D46, D47, D48, D49, D50, D51, D52, D53, D54, D55, D56, D57, D58, D59, D60, D61, D62, D63, D64, D65, D66, D67, D68, D69, D70, D71, D72, D73, D74, D75, D76, D77, D78, D79, D80, D81, D82, D83, D84	84	Green	LED, Green, SMD	1.7x0.65x0.8mm	LG L29K-G2J1-24-Z	OSRAM		
D85, D86	2	Green	LED, Green, SMD	LED_0805	LTST-C171GKT	Lite-On		
D87	1	Red	LED, Red, SMD	LED_0805	LTST-C170KRKT	Lite-On		
H9, H10, H11, H12	4		Bumpon, Hemisphere, 0.44 X 0.20, Clear	Transparent Bumpon	SJ-5303 (CLEAR)	3M		
J1, J2, J3, J4, J5, J6, J7, J8, J9, J10, J11, J14, J15, J16, J17, J18, J19, J20	18		Header, 100mil, 8x1, Tin, TH	Header, 8x1, 100mil, TH	PEC08SAAN	Sullins Connector Solutions		
J12	1		Header (shrouded), 100mil, 5x2, Gold, TH	TH, 10-Leads, Body 8.5x20mm, Pitch 2.54mm	XG4C-1031	Omron Electronic Components		
J13	1		Header (shrouded), 100mil, 7x2, Gold, TH	7x2 Header	N2514-6002-RB	3M		

Table 4. UCD90320EVM-783 BOM (continued)

Designator	Qty	Value	Description	Package Reference	Part Number	Manufacturer	Alternate Part Number	Alternate Manufacturer
J21, J22, J23	3		Header, 100mil, 3x1, Tin, TH	Header, 3 PIN, 100mil, Tin	PEC03SAAN	Sullins Connector Solutions		
J24, J25, J28, J30, J32	5		Header, 100mil, 2x1, Tin, TH	Header, 2 PIN, 100mil, Tin	PEC02SAAN	Sullins Connector Solutions		
J26	1		TERMINAL BLOCK 5.08MM VERT 2POS, TH	TERM_BLK, 2pos, 5.08mm	ED120/2DS	On-Shore Technology		
J27, J29, J31, J33	4		Header, 100mil, 4x1, Tin, TH	Header, 4x1, 100mil, TH	PEC04SAAN	Sullins Connector Solutions		
L1, L2	2	1uH	Inductor, Shielded, Ferrite, 1 µH, 12 A, 0.0072 ohm, SMD	Inductor, 7.2x4x6.5mm	SRP6540-1R0M	Bourns		
Q1, Q2	2	60V	MOSFET, N-CH, 60 V, 0.17 A, SOT-23	SOT-23	2N7002-7-F	Diodes Inc.		None
R1, R10, R39, R40	4	4.7k	RES, 4.7 k, 5%, 0.1 W, 0603	0603	CRCW06034K70JNEA	Vishay-Dale		
R2, R133, R136	3	330	RES, 330, 5%, 0.1 W, 0603	0603	CRCW0603330RJNEA	Vishay-Dale		
R3	1	0.1	RES, 0.1, 1%, 0.1 W, 0603	0603	ERJ-3RSFR10V	Panasonic		
R4	1	1.0	RES, 1.0, 5%, 0.1 W, 0603	0603	CRCW06031R00JNEA	Vishay-Dale		
R5, R6, R7, R8	4	680	RES, 680, 5%, 0.0625 W, Resistor Array - 8x1	Resistor Array - 8x1	EXB-2HV681JV	Panasonic		
R9	1	0	RES, 0, 5%, 0.1 W, 0603	0603	ERJ-3GEY0R00V	Panasonic		
R11, R12, R13	3	1.0k	RES, 1.0 k, 5%, 0.1 W, 0603	0603	RC0603JR-071KL	Yageo America		
R14, R41, R42, R43, R44, R45, R46, R47, R48, R49, R50, R51, R52, R53, R54, R55, R56, R57, R58, R59, R60, R61, R62, R63, R64, R65, R66, R67, R68, R69, R70, R71, R72, R73, R74, R75, R76, R77, R78, R79, R80, R81, R82, R83, R84, R85, R86, R87, R88, R89, R90, R91, R92, R93, R94, R95, R96, R97, R98, R99, R100, R101, R102, R103, R104, R105, R106, R107, R108, R109, R110, R111, R112, R113, R114, R115, R116, R117, R118, R119, R120, R121, R122, R123	84	1.65k	RES, 1.65 k, 1%, 0.1 W, 0603	0603	RC0603FR-071K65L	Yageo America		
R15, R16, R17, R18, R19, R20, R21, R22, R23, R24, R25, R26, R27, R28, R29, R30, R31, R32, R33, R34, R35, R36, R37, R38	24	200	RES, 200, 0.1%, 0.1 W, 0603	0603	RG1608P-201-B-T5	Susumu Co Ltd		
R124, R138	2	0	RES, 0, 5%, 0.063 W, 0402	0402	CRCW04020000Z0ED	Vishay-Dale		
R125, R140	2	40.2	RES, 40.2, 1%, 0.1 W, 0603	0603	RC0603FR-0740R2L	Yageo America		
R126, R127, R128, R139, R141, R143, R148, R154	8	20.0k	RES, 20.0 k, 1%, 0.063 W, 0402	0402	CRCW040220K0FKED	Vishay-Dale		
R129, R132, R142, R144, R149, R155	6	10k	RES, 10 k, 5%, 0.063 W, 0402	0402	CRCW040210K0JNED	Vishay-Dale		
R130, R145	2	196k	RES, 196 k, 1%, 0.1 W, 0603	0603	CRCW0603196KFKEA	Vishay-Dale		
R131, R146, R152, R158	4	1.00k	RES, 1.00 k, 1%, 0.1 W, 0603	0603	CRCW06031K00FKEA	Vishay-Dale		
R134, R135	2	30.1k	RES, 30.1 k, 1%, 0.1 W, 0603	0603	RC0603FR-0730K1L	Yageo America		

Table 4. UCD90320EVM-783 BOM (continued)

Designator	Qty	Value	Description	Package Reference	Part Number	Manufacturer	Alternate Part Number	Alternate Manufacturer
R137, R147	2	82.5k	RES, 82.5 k, 1%, 0.063 W, 0402	0402	CRCW040282K5FKED	Vishay-Dale		
R150, R156	2	12.1k	RES, 12.1 k, 1%, 0.1 W, 0603	0603	CRCW060312K1FKEA	Vishay-Dale		
R151, R157	2	120k	RES, 120 k, 5%, 0.1 W, 0603	0603	CRCW0603120KJNEA	Vishay-Dale		
R153, R159	2	24.3k	RES, 24.3 k, 1%, 0.1 W, 0603	0603	CRCW060324K3FKEA	Vishay-Dale		
R160, R161, R162, R163, R164, R165, R166, R167, R168, R169, R170, R171, R172, R173, R174, R175, R176, R177, R178, R179, R180, R181, R182, R183	24	30	RES, 30, 5%, 0.063 W, 0402	0402	CRCW040230R0JNED	Vishay-Dale		
S1	1		Switch, Tactile, SPST-NO, 1VA, 32V, SMT	Switch, 6.3x5.36x6.6 mm, SMT	KT11P2JM34LFS	C&K Components		
SH-J1, SH-J2, SH-J3, SH-J4, SH-J5, SH-J6, SH-J7, SH-J8	8	1x2	Shunt, 100mil, Gold plated, Black	Shunt	969102-0000-DA	3M	SNT-100-BK-G	Samtec
TP1, TP2, TP3, TP4, TP5, TP6	6	SMT	Test Point, Compact, SMT	Testpoint_Keystone_C ompact	5016	Keystone		
TP8	1	Red	Test Point, Multipurpose, Red, TH	Red Multipurpose Testpoint	5010	Keystone		
TP9	1	Black	Test Point, Multipurpose, Black, TH	Black Multipurpose Testpoint	5011	Keystone		
TP10, TP11, TP12, TP13, TP14	5	Yellow	Test Point, Miniature, Yellow, TH	Yellow Miniature Testpoint	5004	Keystone		
U1	1		32-Rail PMBus Power Sequencer and System Manager, ZWS0169A	ZWS0169A	UCD90320ZWSR	Texas Instruments	UCD90320ZWST	Texas Instruments
U2	1		Low Noise, Very Low Drift, Precision Voltage Reference, -40 to 125 degC, 8-pin MSOP (DGK), Green (RoHS & no Sb/Br)	DGK0008A	REF5030AIDGKT	Texas Instruments	Equivalent	None
U3, U6	2		2.95 V to 6 V INPUT, 6 A OUTPUT, 2 MHz, SYNCHRONOUS STEP DOWN SWITCHER WITH INTEGRATED FET (SWIFT™), RTE0016F	RTE0016F	TPS54678RTER	Texas Instruments	TPS54678RTET	Texas Instruments
U4	1		Single Output Low Noise LDO, 400 mA, Fixed 3.3 V Output, 1.7 to 5.5 V Input, with Reverse Current Protection, 8-pin SON (DRB), -40 to 85 degC, Green (RoHS & no Sb/Br)	DRB0008A	TPS73633DRBR	Texas Instruments	Equivalent	None
U5	1		Single Inverter Gate, DBV0005A	DBV0005A	SN74LVC1G04DBVR	Texas Instruments	SN74LVC1G04DBVT	Texas Instruments
U7, U8	2		2-A, 6- μ VRMS, RF, LDO Voltage Regulator, RGR0020A	RGR0020A	TPS7A8400RGRR	Texas Instruments	TPS7A8400RGRT	Texas Instruments
C6, C48	0	DNP	CAP, CERM, 22 pF, 50 V, +/- 5%, C0G/NP0, 0402	0402	GRM1555C1H220JA01D	Murata		
FID1, FID2, FID3, FID4, FID5, FID6	0		Fiducial mark. There is nothing to buy or mount.	N/A	N/A	N/A		
Notes: Unless otherwise noted in the Alternate Part Number and/or Alternate Manufacturer columns, all parts may be substituted with equivalents.								

STANDARD TERMS AND CONDITIONS FOR EVALUATION MODULES

1. *Delivery:* TI delivers TI evaluation boards, kits, or modules, including any accompanying demonstration software, components, or documentation (collectively, an "EVM" or "EVMs") to the User ("User") in accordance with the terms and conditions set forth herein. Acceptance of the EVM is expressly subject to the following terms and conditions.
 - 1.1 EVMs are intended solely for product or software developers for use in a research and development setting to facilitate feasibility evaluation, experimentation, or scientific analysis of TI semiconductors products. EVMs have no direct function and are not finished products. EVMs shall not be directly or indirectly assembled as a part or subassembly in any finished product. For clarification, any software or software tools provided with the EVM ("Software") shall not be subject to the terms and conditions set forth herein but rather shall be subject to the applicable terms and conditions that accompany such Software
 - 1.2 EVMs are not intended for consumer or household use. EVMs may not be sold, sublicensed, leased, rented, loaned, assigned, or otherwise distributed for commercial purposes by Users, in whole or in part, or used in any finished product or production system.
2. *Limited Warranty and Related Remedies/Disclaimers:*
 - 2.1 These terms and conditions do not apply to Software. The warranty, if any, for Software is covered in the applicable Software License Agreement.
 - 2.2 TI warrants that the TI EVM will conform to TI's published specifications for ninety (90) days after the date TI delivers such EVM to User. Notwithstanding the foregoing, TI shall not be liable for any defects that are caused by neglect, misuse or mistreatment by an entity other than TI, including improper installation or testing, or for any EVMs that have been altered or modified in any way by an entity other than TI. Moreover, TI shall not be liable for any defects that result from User's design, specifications or instructions for such EVMs. Testing and other quality control techniques are used to the extent TI deems necessary or as mandated by government requirements. TI does not test all parameters of each EVM.
 - 2.3 If any EVM fails to conform to the warranty set forth above, TI's sole liability shall be at its option to repair or replace such EVM, or credit User's account for such EVM. TI's liability under this warranty shall be limited to EVMs that are returned during the warranty period to the address designated by TI and that are determined by TI not to conform to such warranty. If TI elects to repair or replace such EVM, TI shall have a reasonable time to repair such EVM or provide replacements. Repaired EVMs shall be warranted for the remainder of the original warranty period. Replaced EVMs shall be warranted for a new full ninety (90) day warranty period.
3. *Regulatory Notices:*
 - 3.1 *United States*
 - 3.1.1 *Notice applicable to EVMs not FCC-Approved:*

This kit is designed to allow product developers to evaluate electronic components, circuitry, or software associated with the kit to determine whether to incorporate such items in a finished product and software developers to write software applications for use with the end product. This kit is not a finished product and when assembled may not be resold or otherwise marketed unless all required FCC equipment authorizations are first obtained. Operation is subject to the condition that this product not cause harmful interference to licensed radio stations and that this product accept harmful interference. Unless the assembled kit is designed to operate under part 15, part 18 or part 95 of this chapter, the operator of the kit must operate under the authority of an FCC license holder or must secure an experimental authorization under part 5 of this chapter.
 - 3.1.2 *For EVMs annotated as FCC – FEDERAL COMMUNICATIONS COMMISSION Part 15 Compliant:*

CAUTION

This device complies with part 15 of the FCC Rules. Operation is subject to the following two conditions: (1) This device may not cause harmful interference, and (2) this device must accept any interference received, including interference that may cause undesired operation.

Changes or modifications not expressly approved by the party responsible for compliance could void the user's authority to operate the equipment.

FCC Interference Statement for Class A EVM devices

NOTE: This equipment has been tested and found to comply with the limits for a Class A digital device, pursuant to part 15 of the FCC Rules. These limits are designed to provide reasonable protection against harmful interference when the equipment is operated in a commercial environment. This equipment generates, uses, and can radiate radio frequency energy and, if not installed and used in accordance with the instruction manual, may cause harmful interference to radio communications. Operation of this equipment in a residential area is likely to cause harmful interference in which case the user will be required to correct the interference at his own expense.

FCC Interference Statement for Class B EVM devices

NOTE: This equipment has been tested and found to comply with the limits for a Class B digital device, pursuant to part 15 of the FCC Rules. These limits are designed to provide reasonable protection against harmful interference in a residential installation. This equipment generates, uses and can radiate radio frequency energy and, if not installed and used in accordance with the instructions, may cause harmful interference to radio communications. However, there is no guarantee that interference will not occur in a particular installation. If this equipment does cause harmful interference to radio or television reception, which can be determined by turning the equipment off and on, the user is encouraged to try to correct the interference by one or more of the following measures:

- Reorient or relocate the receiving antenna.
- Increase the separation between the equipment and receiver.
- Connect the equipment into an outlet on a circuit different from that to which the receiver is connected.
- Consult the dealer or an experienced radio/TV technician for help.

3.2 Canada

3.2.1 For EVMs issued with an Industry Canada Certificate of Conformance to RSS-210

Concerning EVMs Including Radio Transmitters:

This device complies with Industry Canada license-exempt RSS standard(s). Operation is subject to the following two conditions: (1) this device may not cause interference, and (2) this device must accept any interference, including interference that may cause undesired operation of the device.

Concernant les EVMs avec appareils radio:

Le présent appareil est conforme aux CNR d'Industrie Canada applicables aux appareils radio exempts de licence. L'exploitation est autorisée aux deux conditions suivantes: (1) l'appareil ne doit pas produire de brouillage, et (2) l'utilisateur de l'appareil doit accepter tout brouillage radioélectrique subi, même si le brouillage est susceptible d'en compromettre le fonctionnement.

Concerning EVMs Including Detachable Antennas:

Under Industry Canada regulations, this radio transmitter may only operate using an antenna of a type and maximum (or lesser) gain approved for the transmitter by Industry Canada. To reduce potential radio interference to other users, the antenna type and its gain should be so chosen that the equivalent isotropically radiated power (e.i.r.p.) is not more than that necessary for successful communication. This radio transmitter has been approved by Industry Canada to operate with the antenna types listed in the user guide with the maximum permissible gain and required antenna impedance for each antenna type indicated. Antenna types not included in this list, having a gain greater than the maximum gain indicated for that type, are strictly prohibited for use with this device.

Concernant les EVMs avec antennes détachables

Conformément à la réglementation d'Industrie Canada, le présent émetteur radio peut fonctionner avec une antenne d'un type et d'un gain maximal (ou inférieur) approuvé pour l'émetteur par Industrie Canada. Dans le but de réduire les risques de brouillage radioélectrique à l'intention des autres utilisateurs, il faut choisir le type d'antenne et son gain de sorte que la puissance isotrope rayonnée équivalente (p.i.r.e.) ne dépasse pas l'intensité nécessaire à l'établissement d'une communication satisfaisante. Le présent émetteur radio a été approuvé par Industrie Canada pour fonctionner avec les types d'antenne énumérés dans le manuel d'usage et ayant un gain admissible maximal et l'impédance requise pour chaque type d'antenne. Les types d'antenne non inclus dans cette liste, ou dont le gain est supérieur au gain maximal indiqué, sont strictement interdits pour l'exploitation de l'émetteur.

3.3 Japan

3.3.1 *Notice for EVMs delivered in Japan:* Please see http://www.tij.co.jp/lstds/ti_ja/general/eStore/notice_01.page 日本国内に輸入される評価用キット、ボードについては、次のところをご覧ください。
http://www.tij.co.jp/lstds/ti_ja/general/eStore/notice_01.page

3.3.2 *Notice for Users of EVMs Considered "Radio Frequency Products" in Japan:* EVMs entering Japan may not be certified by TI as conforming to Technical Regulations of Radio Law of Japan.

If User uses EVMs in Japan, not certified to Technical Regulations of Radio Law of Japan, User is required by Radio Law of Japan to follow the instructions below with respect to EVMs:

1. Use EVMs in a shielded room or any other test facility as defined in the notification #173 issued by Ministry of Internal Affairs and Communications on March 28, 2006, based on Sub-section 1.1 of Article 6 of the Ministry's Rule for Enforcement of Radio Law of Japan,
2. Use EVMs only after User obtains the license of Test Radio Station as provided in Radio Law of Japan with respect to EVMs, or
3. Use of EVMs only after User obtains the Technical Regulations Conformity Certification as provided in Radio Law of Japan with respect to EVMs. Also, do not transfer EVMs, unless User gives the same notice above to the transferee. Please note that if User does not follow the instructions above, User will be subject to penalties of Radio Law of Japan.

【無線電波を送信する製品の開発キットをお使いになる際の注意事項】 開発キットの中には技術基準適合証明を受けていないものがあります。技術適合証明を受けていないもののご使用に際しては、電波法遵守のため、以下のいずれかの措置を取っていただく必要がありますのでご注意ください。

1. 電波法施行規則第6条第1項第1号に基づく平成18年3月28日総務省告示第173号で定められた電波暗室等の試験設備でご使用いただく。
2. 実験局の免許を取得後ご使用いただく。
3. 技術基準適合証明を取得後ご使用いただく。

なお、本製品は、上記の「ご使用にあたっての注意」を譲渡先、移転先に通知しない限り、譲渡、移転できないものとします。

上記を遵守頂けない場合は、電波法の罰則が適用される可能性があることをご留意ください。日本テキサス・インスツルメンツ株式会社

東京都新宿区西新宿 6 丁目 2 4 番 1 号

西新宿三井ビル

3.3.3 *Notice for EVMs for Power Line Communication:* Please see http://www.tij.co.jp/llds/ti_ja/general/eStore/notice_02.page

電力線搬送波通信についての開発キットをお使いになる際の注意事項については、次のところをご覧ください。http://www.tij.co.jp/llds/ti_ja/general/eStore/notice_02.page

4 *EVM Use Restrictions and Warnings:*

4.1 EVMS ARE NOT FOR USE IN FUNCTIONAL SAFETY AND/OR SAFETY CRITICAL EVALUATIONS, INCLUDING BUT NOT LIMITED TO EVALUATIONS OF LIFE SUPPORT APPLICATIONS.

4.2 User must read and apply the user guide and other available documentation provided by TI regarding the EVM prior to handling or using the EVM, including without limitation any warning or restriction notices. The notices contain important safety information related to, for example, temperatures and voltages.

4.3 *Safety-Related Warnings and Restrictions:*

4.3.1 User shall operate the EVM within TI's recommended specifications and environmental considerations stated in the user guide, other available documentation provided by TI, and any other applicable requirements and employ reasonable and customary safeguards. Exceeding the specified performance ratings and specifications (including but not limited to input and output voltage, current, power, and environmental ranges) for the EVM may cause personal injury or death, or property damage. If there are questions concerning performance ratings and specifications, User should contact a TI field representative prior to connecting interface electronics including input power and intended loads. Any loads applied outside of the specified output range may also result in unintended and/or inaccurate operation and/or possible permanent damage to the EVM and/or interface electronics. Please consult the EVM user guide prior to connecting any load to the EVM output. If there is uncertainty as to the load specification, please contact a TI field representative. During normal operation, even with the inputs and outputs kept within the specified allowable ranges, some circuit components may have elevated case temperatures. These components include but are not limited to linear regulators, switching transistors, pass transistors, current sense resistors, and heat sinks, which can be identified using the information in the associated documentation. When working with the EVM, please be aware that the EVM may become very warm.

4.3.2 EVMs are intended solely for use by technically qualified, professional electronics experts who are familiar with the dangers and application risks associated with handling electrical mechanical components, systems, and subsystems. User assumes all responsibility and liability for proper and safe handling and use of the EVM by User or its employees, affiliates, contractors or designees. User assumes all responsibility and liability to ensure that any interfaces (electronic and/or mechanical) between the EVM and any human body are designed with suitable isolation and means to safely limit accessible leakage currents to minimize the risk of electrical shock hazard. User assumes all responsibility and liability for any improper or unsafe handling or use of the EVM by User or its employees, affiliates, contractors or designees.

4.4 User assumes all responsibility and liability to determine whether the EVM is subject to any applicable international, federal, state, or local laws and regulations related to User's handling and use of the EVM and, if applicable, User assumes all responsibility and liability for compliance in all respects with such laws and regulations. User assumes all responsibility and liability for proper disposal and recycling of the EVM consistent with all applicable international, federal, state, and local requirements.

5. *Accuracy of Information:* To the extent TI provides information on the availability and function of EVMs, TI attempts to be as accurate as possible. However, TI does not warrant the accuracy of EVM descriptions, EVM availability or other information on its websites as accurate, complete, reliable, current, or error-free.

6. *Disclaimers:*
- 6.1 EXCEPT AS SET FORTH ABOVE, EVMS AND ANY WRITTEN DESIGN MATERIALS PROVIDED WITH THE EVM (AND THE DESIGN OF THE EVM ITSELF) ARE PROVIDED "AS IS" AND "WITH ALL FAULTS." TI DISCLAIMS ALL OTHER WARRANTIES, EXPRESS OR IMPLIED, REGARDING SUCH ITEMS, INCLUDING BUT NOT LIMITED TO ANY IMPLIED WARRANTIES OF MERCHANTABILITY OR FITNESS FOR A PARTICULAR PURPOSE OR NON-INFRINGEMENT OF ANY THIRD PARTY PATENTS, COPYRIGHTS, TRADE SECRETS OR OTHER INTELLECTUAL PROPERTY RIGHTS.
- 6.2 EXCEPT FOR THE LIMITED RIGHT TO USE THE EVM SET FORTH HEREIN, NOTHING IN THESE TERMS AND CONDITIONS SHALL BE CONSTRUED AS GRANTING OR CONFERRING ANY RIGHTS BY LICENSE, PATENT, OR ANY OTHER INDUSTRIAL OR INTELLECTUAL PROPERTY RIGHT OF TI, ITS SUPPLIERS/LICENSORS OR ANY OTHER THIRD PARTY, TO USE THE EVM IN ANY FINISHED END-USER OR READY-TO-USE FINAL PRODUCT, OR FOR ANY INVENTION, DISCOVERY OR IMPROVEMENT MADE, CONCEIVED OR ACQUIRED PRIOR TO OR AFTER DELIVERY OF THE EVM.
7. *USER'S INDEMNITY OBLIGATIONS AND REPRESENTATIONS.* USER WILL DEFEND, INDEMNIFY AND HOLD TI, ITS LICENSORS AND THEIR REPRESENTATIVES HARMLESS FROM AND AGAINST ANY AND ALL CLAIMS, DAMAGES, LOSSES, EXPENSES, COSTS AND LIABILITIES (COLLECTIVELY, "CLAIMS") ARISING OUT OF OR IN CONNECTION WITH ANY HANDLING OR USE OF THE EVM THAT IS NOT IN ACCORDANCE WITH THESE TERMS AND CONDITIONS. THIS OBLIGATION SHALL APPLY WHETHER CLAIMS ARISE UNDER STATUTE, REGULATION, OR THE LAW OF TORT, CONTRACT OR ANY OTHER LEGAL THEORY, AND EVEN IF THE EVM FAILS TO PERFORM AS DESCRIBED OR EXPECTED.
8. *Limitations on Damages and Liability:*
- 8.1 *General Limitations.* IN NO EVENT SHALL TI BE LIABLE FOR ANY SPECIAL, COLLATERAL, INDIRECT, PUNITIVE, INCIDENTAL, CONSEQUENTIAL, OR EXEMPLARY DAMAGES IN CONNECTION WITH OR ARISING OUT OF THESE TERMS AND CONDITIONS OR THE USE OF THE EVMS PROVIDED HEREUNDER, REGARDLESS OF WHETHER TI HAS BEEN ADVISED OF THE POSSIBILITY OF SUCH DAMAGES. EXCLUDED DAMAGES INCLUDE, BUT ARE NOT LIMITED TO, COST OF REMOVAL OR REINSTALLATION, ANCILLARY COSTS TO THE PROCUREMENT OF SUBSTITUTE GOODS OR SERVICES, RETESTING, OUTSIDE COMPUTER TIME, LABOR COSTS, LOSS OF GOODWILL, LOSS OF PROFITS, LOSS OF SAVINGS, LOSS OF USE, LOSS OF DATA, OR BUSINESS INTERRUPTION. NO CLAIM, SUIT OR ACTION SHALL BE BROUGHT AGAINST TI MORE THAN ONE YEAR AFTER THE RELATED CAUSE OF ACTION HAS OCCURRED.
- 8.2 *Specific Limitations.* IN NO EVENT SHALL TI'S AGGREGATE LIABILITY FROM ANY WARRANTY OR OTHER OBLIGATION ARISING OUT OF OR IN CONNECTION WITH THESE TERMS AND CONDITIONS, OR ANY USE OF ANY TI EVM PROVIDED HEREUNDER, EXCEED THE TOTAL AMOUNT PAID TO TI FOR THE PARTICULAR UNITS SOLD UNDER THESE TERMS AND CONDITIONS WITH RESPECT TO WHICH LOSSES OR DAMAGES ARE CLAIMED. THE EXISTENCE OF MORE THAN ONE CLAIM AGAINST THE PARTICULAR UNITS SOLD TO USER UNDER THESE TERMS AND CONDITIONS SHALL NOT ENLARGE OR EXTEND THIS LIMIT.
9. *Return Policy.* Except as otherwise provided, TI does not offer any refunds, returns, or exchanges. Furthermore, no return of EVM(s) will be accepted if the package has been opened and no return of the EVM(s) will be accepted if they are damaged or otherwise not in a resalable condition. If User feels it has been incorrectly charged for the EVM(s) it ordered or that delivery violates the applicable order, User should contact TI. All refunds will be made in full within thirty (30) working days from the return of the components(s), excluding any postage or packaging costs.
10. *Governing Law:* These terms and conditions shall be governed by and interpreted in accordance with the laws of the State of Texas, without reference to conflict-of-laws principles. User agrees that non-exclusive jurisdiction for any dispute arising out of or relating to these terms and conditions lies within courts located in the State of Texas and consents to venue in Dallas County, Texas. Notwithstanding the foregoing, any judgment may be enforced in any United States or foreign court, and TI may seek injunctive relief in any United States or foreign court.

Mailing Address: Texas Instruments, Post Office Box 655303, Dallas, Texas 75265
Copyright © 2015, Texas Instruments Incorporated

IMPORTANT NOTICE

Texas Instruments Incorporated and its subsidiaries (TI) reserve the right to make corrections, enhancements, improvements and other changes to its semiconductor products and services per JESD46, latest issue, and to discontinue any product or service per JESD48, latest issue. Buyers should obtain the latest relevant information before placing orders and should verify that such information is current and complete. All semiconductor products (also referred to herein as "components") are sold subject to TI's terms and conditions of sale supplied at the time of order acknowledgment.

TI warrants performance of its components to the specifications applicable at the time of sale, in accordance with the warranty in TI's terms and conditions of sale of semiconductor products. Testing and other quality control techniques are used to the extent TI deems necessary to support this warranty. Except where mandated by applicable law, testing of all parameters of each component is not necessarily performed.

TI assumes no liability for applications assistance or the design of Buyers' products. Buyers are responsible for their products and applications using TI components. To minimize the risks associated with Buyers' products and applications, Buyers should provide adequate design and operating safeguards.

TI does not warrant or represent that any license, either express or implied, is granted under any patent right, copyright, mask work right, or other intellectual property right relating to any combination, machine, or process in which TI components or services are used. Information published by TI regarding third-party products or services does not constitute a license to use such products or services or a warranty or endorsement thereof. Use of such information may require a license from a third party under the patents or other intellectual property of the third party, or a license from TI under the patents or other intellectual property of TI.

Reproduction of significant portions of TI information in TI data books or data sheets is permissible only if reproduction is without alteration and is accompanied by all associated warranties, conditions, limitations, and notices. TI is not responsible or liable for such altered documentation. Information of third parties may be subject to additional restrictions.

Resale of TI components or services with statements different from or beyond the parameters stated by TI for that component or service voids all express and any implied warranties for the associated TI component or service and is an unfair and deceptive business practice. TI is not responsible or liable for any such statements.

Buyer acknowledges and agrees that it is solely responsible for compliance with all legal, regulatory and safety-related requirements concerning its products, and any use of TI components in its applications, notwithstanding any applications-related information or support that may be provided by TI. Buyer represents and agrees that it has all the necessary expertise to create and implement safeguards which anticipate dangerous consequences of failures, monitor failures and their consequences, lessen the likelihood of failures that might cause harm and take appropriate remedial actions. Buyer will fully indemnify TI and its representatives against any damages arising out of the use of any TI components in safety-critical applications.

In some cases, TI components may be promoted specifically to facilitate safety-related applications. With such components, TI's goal is to help enable customers to design and create their own end-product solutions that meet applicable functional safety standards and requirements. Nonetheless, such components are subject to these terms.

No TI components are authorized for use in FDA Class III (or similar life-critical medical equipment) unless authorized officers of the parties have executed a special agreement specifically governing such use.

Only those TI components which TI has specifically designated as military grade or "enhanced plastic" are designed and intended for use in military/aerospace applications or environments. Buyer acknowledges and agrees that any military or aerospace use of TI components which have **not** been so designated is solely at the Buyer's risk, and that Buyer is solely responsible for compliance with all legal and regulatory requirements in connection with such use.

TI has specifically designated certain components as meeting ISO/TS16949 requirements, mainly for automotive use. In any case of use of non-designated products, TI will not be responsible for any failure to meet ISO/TS16949.

Products

Audio	www.ti.com/audio
Amplifiers	amplifier.ti.com
Data Converters	dataconverter.ti.com
DLP® Products	www.dlp.com
DSP	dsp.ti.com
Clocks and Timers	www.ti.com/clocks
Interface	interface.ti.com
Logic	logic.ti.com
Power Mgmt	power.ti.com
Microcontrollers	microcontroller.ti.com
RFID	www.ti-rfid.com
OMAP Applications Processors	www.ti.com/omap
Wireless Connectivity	www.ti.com/wirelessconnectivity

Applications

Automotive and Transportation	www.ti.com/automotive
Communications and Telecom	www.ti.com/communications
Computers and Peripherals	www.ti.com/computers
Consumer Electronics	www.ti.com/consumer-apps
Energy and Lighting	www.ti.com/energy
Industrial	www.ti.com/industrial
Medical	www.ti.com/medical
Security	www.ti.com/security
Space, Avionics and Defense	www.ti.com/space-avionics-defense
Video and Imaging	www.ti.com/video

TI E2E Community

e2e.ti.com