

7.5A Fast-Response LDO Regulator

Features

- Fast Transient Response
- 7.5A Current Capability
- 700 mV Dropout Voltage at Full Load
- Low Ground Current
- Accurate 2% Guaranteed Tolerance
- “Zero” Current Shutdown Mode
- Adjustable Output Voltage

Applications

- Pentium®, Pentium® Plus, and Power PC® Processor Supplies
- High-Efficiency “Green” Computer Systems
- High-Efficiency Linear Power Supplies
- High-Efficiency Switching Supply Post Regulator
- Battery-Powered Equipment

Package Type

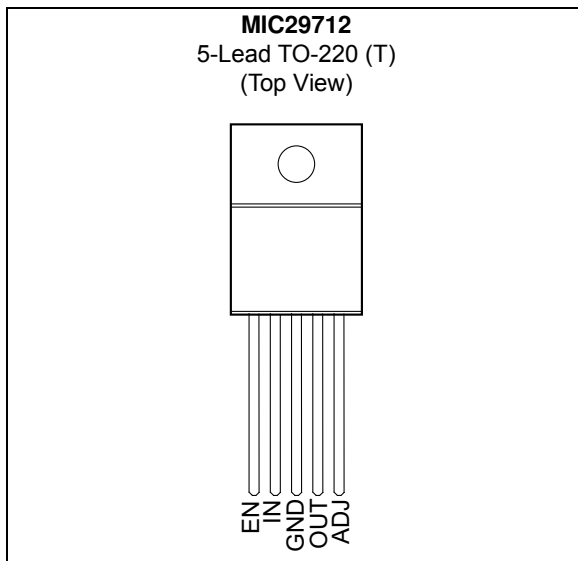

General Description

The MIC29712 is a high-current, high-accuracy, low-dropout voltage regulator that features fast transient recovery from input voltage surges and output load current changes. This regulator uses a PNP pass element that features Microchip’s proprietary Super β PNP process.

The MIC29712 is an adjustable output voltage device. It is fully protected against overcurrent faults, reversed lead insertion, overtemperature operation, and positive and negative transient voltage spikes.

A TTL-compatible enable (EN) control pin supports external on/off control. If on/off control is not required, the device may be continuously enabled by connecting EN to IN.

The MIC29712 is available in the 5-pin TO-220 package with an operating junction temperature range of 0°C to +125°C.

For applications that require even lower dropout voltage or input voltage greater than 16V, see the MIC29752.

MIC29712

Typical Application Circuit

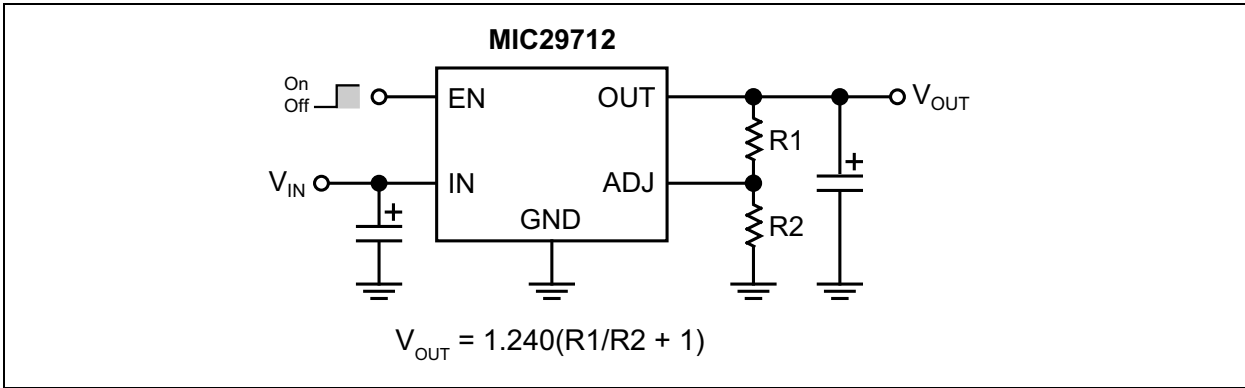

Functional Block Diagram

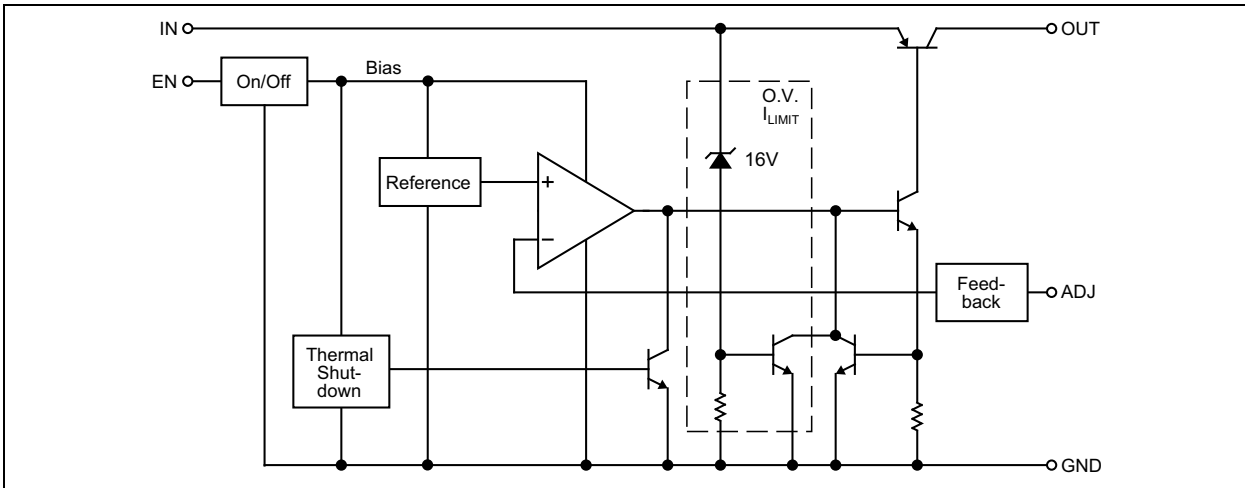

1.0 ELECTRICAL CHARACTERISTICS

Absolute Maximum Ratings †

Input Supply Voltage (V_{IN}) (Note 1)	-0.7V to +20V
Power Dissipation	Internally Limited
Lead Temperature (Soldering, 5 sec.)	+260°C
Storage Temperature (T_S)	-65°C to +150°C
ESD Rating	Note 2

Operating Ratings ††

Junction Temperature (T_J)	0°C to +125°C
Package Thermal Resistance		
TO-220 (θ_{JC})	2°C/W
TO-220 (θ_{JA})	55°C/W

† **Notice:** Stresses above those listed under “Absolute Maximum Ratings” may cause permanent damage to the device. This is a stress rating only and functional operation of the device at those or any other conditions above those indicated in the operational sections of this specification is not intended. Exposure to maximum rating conditions for extended periods may affect device reliability.

†† **Notice:** The device is not guaranteed to function outside its operating ratings.

Note 1: The maximum continuous supply voltage is 16V.

2: Devices are ESD sensitive. Handling precautions are recommended.

ELECTRICAL CHARACTERISTICS

Electrical Characteristics: All measurements at $T_J = +25^\circ\text{C}$ unless otherwise noted. **Bold** values are guaranteed across the operating temperature range. Note 1

Parameter	Sym.	Min.	Typ.	Max.	Units	Conditions
Output Voltage	V_{OUT}	-2	—	2	%	$10\text{ mA} \leq I_{OUT} \leq 7.5\text{A}$, $(V_{OUT} + 1\text{V}) \leq V_{IN} \leq 8\text{V}$, Note 2
Line Regulation	$\frac{\Delta V_{OUT}}{V_{OUT}}$	—	0.06	0.5	%	$I_{OUT} = 10\text{ mA}$, $(V_{OUT} + 1\text{V}) \leq V_{IN} \leq 8\text{V}$
Load Regulation	$\frac{\Delta V_{OUT}}{V_{OUT}}$	—	0.2	1	%	$V_{IN} = V_{OUT} + 1\text{V}$, $10\text{ mA} \leq I_{OUT} \leq 7.5\text{A}$, Note 2
Output Voltage Temperature Coefficient	$\frac{\Delta V_{OUT}}{\Delta T}$	—	20	100	ppm/°C	Note 4

Note 1: Specification for packaged product only.

2: For testing, MIC29712 V_{OUT} is programmed to 5V.

3: $V_{EN} \leq 0.8\text{V}$ and $V_{IN} \leq 16\text{V}$, $V_{OUT} = 0$.

4: Output voltage temperature coefficient is defined as the worst-case voltage change divided by the total temperature range.

5: Dropout voltage is defined as the input-to-output differential when the output voltage drops to 99% of its nominal value with $V_{OUT} + 1\text{V}$ applied to V_{IN} .

6: Ground pin current is the regulator quiescent current. The total current drawn from the source is the sum of the load current plus the ground pin current.

7: For this test, V_{IN} is the larger of 8V or $V_{OUT} + 3\text{V}$.

8: $V_{REF} \leq V_{OUT} \leq (V_{IN} - 1\text{V})$, $2.4\text{V} \leq V_{IN} \leq 8\text{V}$, $10\text{ mA} < I_L \leq 7.5\text{A}$, $T_J \leq T_{J(\text{MAX})}$.

MIC29712

ELECTRICAL CHARACTERISTICS (CONTINUED)

Electrical Characteristics: All measurements at $T_J = +25^\circ\text{C}$ unless otherwise noted. **Bold** values are guaranteed across the operating temperature range. [Note 1](#)

Parameter	Sym.	Min.	Typ.	Max.	Units	Conditions
Dropout Voltage $\Delta V_{\text{OUT}} = -1\%$ (Note 5)	V_{DO}	—	80	200	mV	$I_{\text{OUT}} = 100 \text{ mA}$
		—	180	—		$I_{\text{OUT}} = 750 \text{ mA}$
		—	220	—		$I_{\text{OUT}} = 1.5 \text{ A}$
		—	300	—		$I_{\text{OUT}} = 3 \text{ A}$
		—	450	—		$I_{\text{OUT}} = 5 \text{ A}$
		—	700	1000		$I_{\text{OUT}} = 7.5 \text{ A}$
Ground Current (Note 6)	I_{GND}	—	6	20	mA	$I_{\text{OUT}} = 750 \text{ mA}, V_{\text{IN}} = V_{\text{OUT}} + 1 \text{ V}$
		—	20	—		$I_{\text{OUT}} = 1.5 \text{ A}$
		—	36	—		$I_{\text{OUT}} = 3 \text{ A}$
		—	100	—		$I_{\text{OUT}} = 5 \text{ A}$
		—	250	375		$I_{\text{OUT}} = 7.5 \text{ A}$
Ground Pin Current at Dropout	I_{GNDDO}	—	1	2	mA	$V_{\text{IN}} = 0.5 \text{ V}$ less than specified V_{OUT} . $I_{\text{OUT}} = 10 \text{ mA}$
Current Limit	I_{LIM}	—	11	15	A	$V_{\text{OUT}} = 0 \text{ V}$, Note 7
Output Noise Voltage 10 Hz to 10 kHz	e_n	—	260	—	μV_{RMS}	$C_L = 47 \mu\text{F}$, $I_{\text{OUT}} = 100 \text{ mA}$, $V_{\text{OUT}} = 5 \text{ V}$
Reference						
Reference Voltage	V_{REF}	1.215	1.240	1.265	V	$10 \text{ mA} \leq I_{\text{OUT}} \leq 7.5 \text{ A}$, $(V_{\text{OUT}} + 1 \text{ V}) \leq V_{\text{IN}} \leq 8 \text{ V}$, Note 2
Adjust Pin Bias Current	I_{BIAS}	—	40	80	nA	—
		—	—	120		
Reference Voltage Temperature Coefficient	—	—	20	—	ppm/ $^\circ\text{C}$	Note 8
Adjust Pin Bias Current Temperature Coefficient	—	—	0.1	—	nA/ $^\circ\text{C}$	—
Enable Input						
Input Logic Voltage	V_{IL}	—	—	0.8	V	Low (off)
	V_{IH}	2.4	—	—		High (on)

Note 1: Specification for packaged product only.

2: For testing, MIC29712 V_{OUT} is programmed to 5V.

3: $V_{\text{EN}} \leq 0.8 \text{ V}$ and $V_{\text{IN}} \leq 16 \text{ V}$, $V_{\text{OUT}} = 0$.

4: Output voltage temperature coefficient is defined as the worst-case voltage change divided by the total temperature range.

5: Dropout voltage is defined as the input-to-output differential when the output voltage drops to 99% of its nominal value with $V_{\text{OUT}} + 1 \text{ V}$ applied to V_{IN} .

6: Ground pin current is the regulator quiescent current. The total current drawn from the source is the sum of the load current plus the ground pin current.

7: For this test, V_{IN} is the larger of 8V or $V_{\text{OUT}} + 3 \text{ V}$.

8: $V_{\text{REF}} \leq V_{\text{OUT}} \leq (V_{\text{IN}} - 1 \text{ V})$, $2.4 \text{ V} \leq V_{\text{IN}} \leq 8 \text{ V}$, $10 \text{ mA} < I_L \leq 7.5 \text{ A}$, $T_J \leq T_{J(\text{MAX})}$.

ELECTRICAL CHARACTERISTICS (CONTINUED)

Electrical Characteristics: All measurements at $T_J = +25^\circ\text{C}$ unless otherwise noted. **Bold** values are guaranteed across the operating temperature range. [Note 1](#)

Parameter	Sym.	Min.	Typ.	Max.	Units	Conditions
Enable Pin Input Current	I_{IN}	—	15	30	μA	$V_{EN} = V_{IN}$
		—	—	75		
		—	—	2		$V_{EN} = 0.8\text{V}$
		—	—	4		
Regulator Output Current in Shutdown	—	—	10	—	μA	Note 3
		—	—	20		

Note 1: Specification for packaged product only.

2: For testing, MIC29712 V_{OUT} is programmed to 5V.

3: $V_{EN} \leq 0.8\text{V}$ and $V_{IN} \leq 16\text{V}$, $V_{OUT} = 0$.

4: Output voltage temperature coefficient is defined as the worst-case voltage change divided by the total temperature range.

5: Dropout voltage is defined as the input-to-output differential when the output voltage drops to 99% of its nominal value with $V_{OUT} + 1\text{V}$ applied to V_{IN} .

6: Ground pin current is the regulator quiescent current. The total current drawn from the source is the sum of the load current plus the ground pin current.

7: For this test, V_{IN} is the larger of 8V or $V_{OUT} + 3\text{V}$.

8: $V_{REF} \leq V_{OUT} \leq (V_{IN} - 1\text{V})$, $2.4\text{V} \leq V_{IN} \leq 8\text{V}$, $10\text{mA} < I_L \leq 7.5\text{A}$, $T_J \leq T_{J(\text{MAX})}$.

MIC29712

TEMPERATURE SPECIFICATIONS

Parameters	Sym.	Min.	Typ.	Max.	Units	Conditions
Temperature Ranges						
Operating Temperature Range	T_J	0	—	+125	°C	—
Lead Temperature	—	—	—	+260	°C	Soldering, 5 sec.
Storage Temperature	T_S	-65	—	+150	°C	—
Package Thermal Resistances						
Thermal Resistance, TO-220 5-Ld	θ_{JC}	—	2	—	°C/W	—
Thermal Resistance, TO-220 5-Ld	θ_{JA}	—	55	—	°C/W	—

Note 1: The maximum allowable power dissipation is a function of ambient temperature, the maximum allowable junction temperature and the thermal resistance from junction to air (i.e., T_A , T_J , θ_{JA}). Exceeding the maximum allowable power dissipation will cause the device operating junction temperature to exceed the maximum +125°C rating. Sustained junction temperatures above +125°C can impact the device reliability.

2.0 TYPICAL PERFORMANCE CURVES

Note: The graphs and tables provided following this note are a statistical summary based on a limited number of samples and are provided for informational purposes only. The performance characteristics listed herein are not tested or guaranteed. In some graphs or tables, the data presented may be outside the specified operating range (e.g., outside specified power supply range) and therefore outside the warranted range.

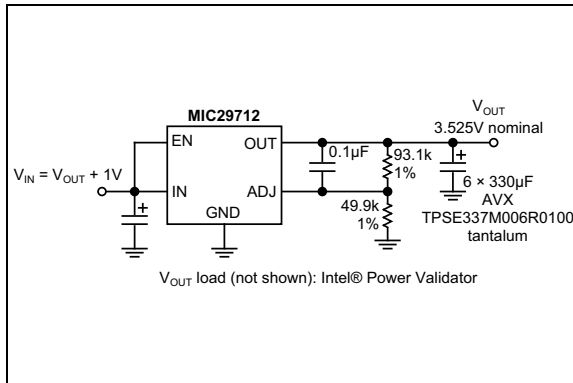

FIGURE 2-1: Load Transient Response Test Circuit.

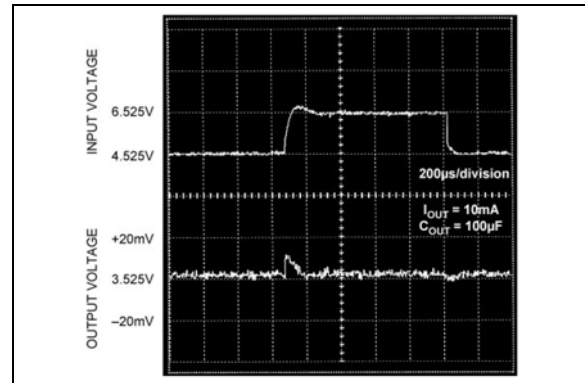

FIGURE 2-4: Line Transient Response with 100 mA Load, 100 µF Output Capacitance.

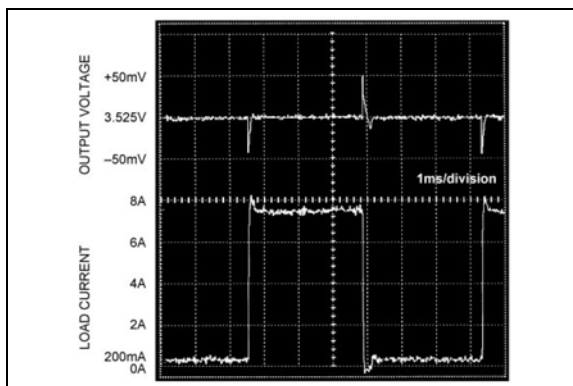

FIGURE 2-2: Load Transient Response (see Figure 2-1).

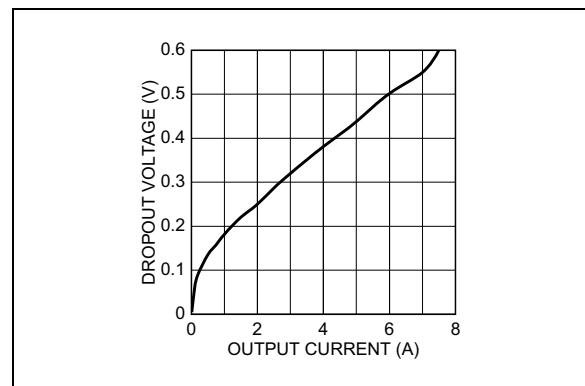

FIGURE 2-5: Dropout Voltage vs. Output Current.

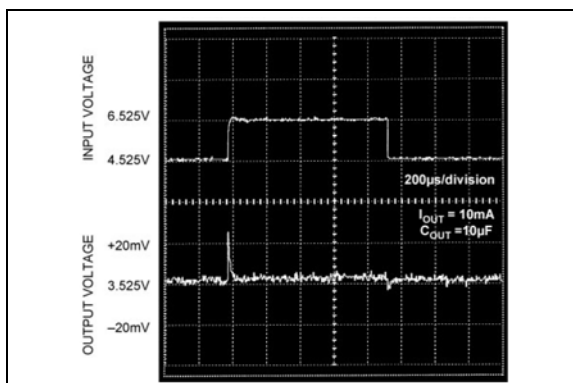

FIGURE 2-3: Line Transient Response with 10 mA Load, 10 µF Output Capacitance.

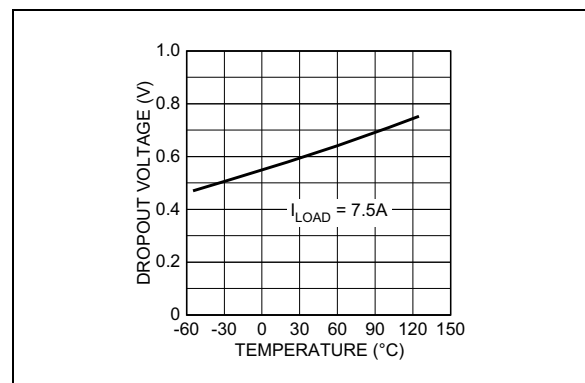

FIGURE 2-6: Dropout Voltage vs. Temperature.

MIC29712

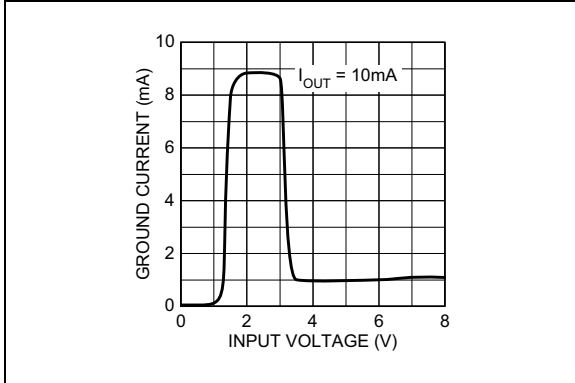

FIGURE 2-7: Ground Current vs Input Voltage.

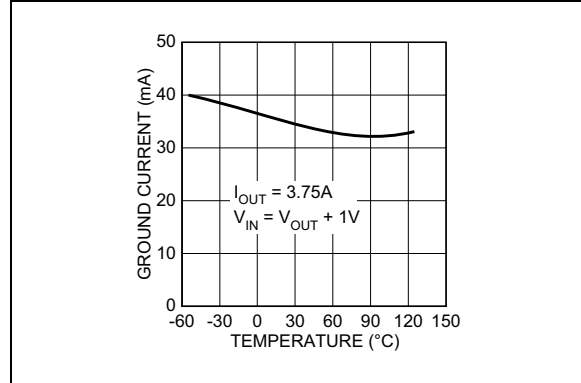

FIGURE 2-10: Ground Current vs Temperature.

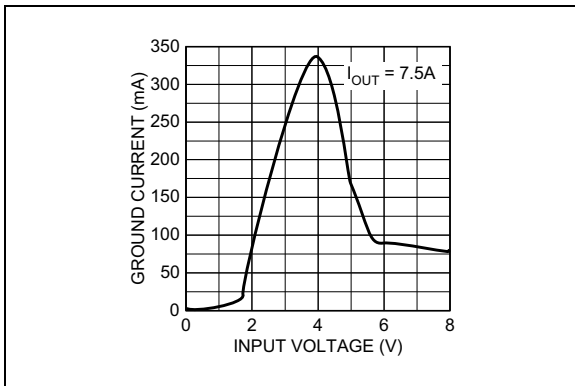

FIGURE 2-8: Ground Current vs Input Voltage.

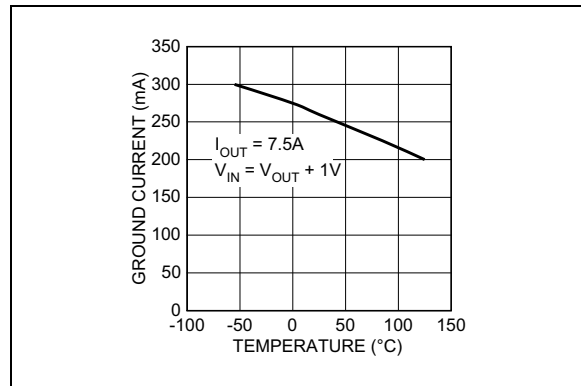

FIGURE 2-11: Ground Current vs Temperature.

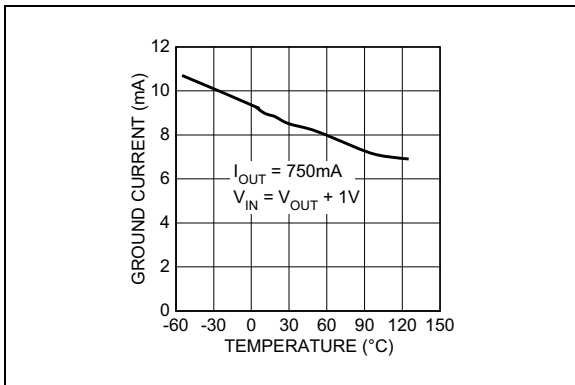

FIGURE 2-9: Ground Current vs Temperature.

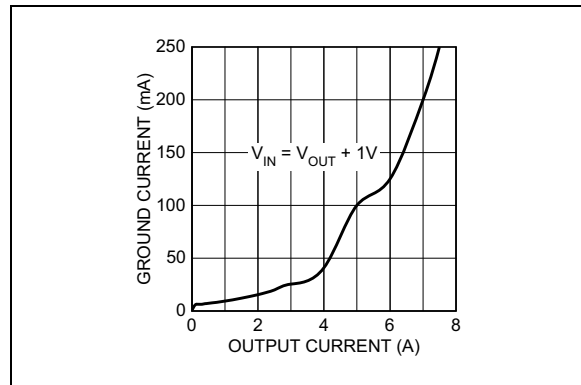

FIGURE 2-12: Ground Current vs. Output Current.

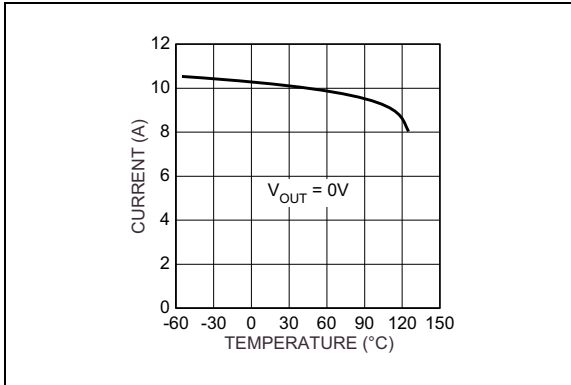

FIGURE 2-13: Short Circuit Current vs. Temperature.

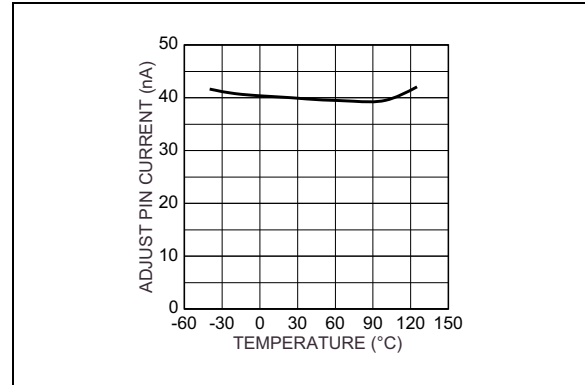

FIGURE 2-15: Adjust Pin Current vs. Temperature.

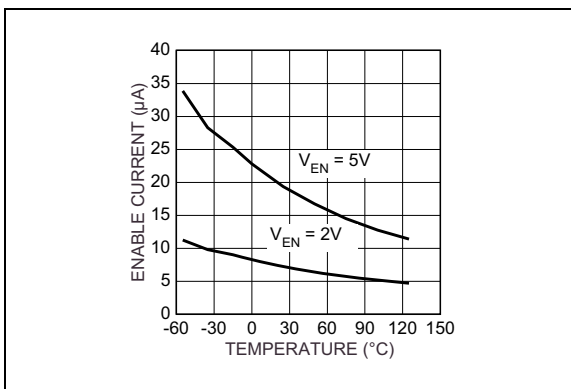

FIGURE 2-14: Enable Current vs. Temperature.

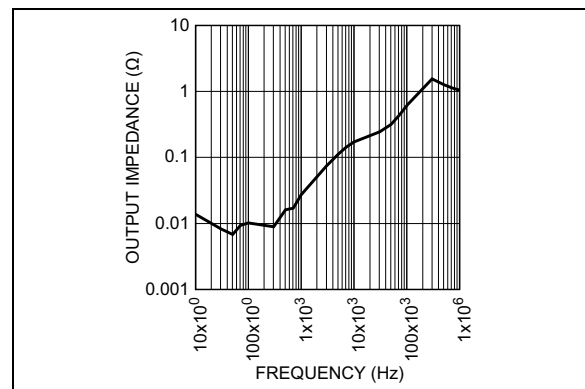

FIGURE 2-16: Output Impedance vs. Frequency.

MIC29712

3.0 PIN DESCRIPTIONS

The descriptions of the pins are listed in [Table 3-1](#).

TABLE 3-1: PIN FUNCTION TABLE

Pin Number	Pin Name	Description
1	EN	Enable (Input): Logic-level ON/OFF control. Do not leave this pin floating.
2	IN	Unregulated Input: +16V maximum supply.
3	GND	Ground: Internally connected to tab (ground).
4	OUT	Regulated Output.
5	ADJ	Output Voltage Adjust: 1.240V feedback from external resistive divider.

4.0 APPLICATION INFORMATION

The MIC29712 is a high performance, low-dropout voltage regulator suitable for all moderate to high-current voltage regulator applications. Its 700 mV of dropout voltage at full load make it especially valuable in battery-powered systems and as high efficiency noise filters in post-regulator applications. Unlike older NPN-pass transistor designs, where the minimum dropout voltage is limited by the base-emitter voltage drop and collector-emitter saturation voltage, dropout performance of the PNP output of this device is limited merely by the low V_{CE} saturation voltage. Output regulation is excellent across the input voltage, output current, and temperature ranges.

A trade-off for the low dropout voltage is a varying base drive requirement. But Microchip's Super β PNP process reduces this drive requirement to merely 2% to 5% of the load current.

The MIC29712 regulator is fully protected from damage due to fault conditions. Current limiting is provided. The output current under overload conditions is limited to a constant value. Thermal shutdown disables the device when the die temperature exceeds the maximum safe operating temperature. Transient protection allows device (and load) survival even when the input voltage spike above and below nominal. The MIC29712 offers a logic level ON/OFF control: when disabled, the devices draw nearly zero current.

An additional feature of this regulator is a common pinout: a design's current requirement may change up or down, but use the same board layout because all of Microchip's high-current Super β PNP regulators have identical pinouts.

4.1 Thermal Design

Linear regulators are simple to use. The most complicated design parameters to consider are thermal characteristics. Thermal design requires the following application-specific parameters:

- Maximum ambient temperature, T_A
- Output Current, I_{OUT}
- Output Voltage, V_{OUT}
- Input Voltage, V_{IN}

First, calculate the power dissipation of the regulator from these values and the device parameters from this data sheet.

EQUATION 4-1:

$$P_D = 1.03I_{OUT} \times (V_{IN} - V_{OUT})$$

Where:
Ground current is approximated by 3% of I_{OUT} .

Then the heat sink thermal resistance is determined with the following formula:

EQUATION 4-2:

$$\theta_{SA} = \frac{T_{J(MAX)} - T_A}{P_D} - (\theta_{JC} + \theta_{CS})$$

Where:
 $T_{J(MAX)} \leq 125^\circ\text{C}$.
 θ_{CS} = Between 0°C/W and 2°C/W .

The heat sink may be significantly reduced in applications where the minimum input voltage is known and is large compared with the dropout voltage. Use a series input resistor to drop excessive voltage and distribute the heat between this resistor and the regulator. The low dropout properties of the Super β PNP regulators allow for significant reductions in regulator power dissipation and the associated heat sink without compromising performance. When this technique is employed, a capacitor of at least 0.1 μF is needed directly between the input and regulator ground.

Please refer to [Application Note 9](#) for further details and examples on thermal design and heat sink specification.

4.2 Capacitor Requirements

For stability and minimum output noise, a capacitor on the regulator output is necessary. The value of this capacitor depends upon the output current; lower currents allow smaller capacitors. MIC29712 is stable with a minimum capacitor value of 47 μF at full load.

This capacitor need not be an expensive low-ESR type: aluminum electrolytics are adequate. In fact, extremely low ESR capacitors may contribute to instability. Tantalum capacitors are recommended for systems where fast load transient response is important.

Where the regulator is powered from a source with a high AC impedance, a 0.1 μF capacitor connected between input and GND is recommended. This capacitor should have good characteristics to above 250 kHz.

MIC29712

4.3 Transient Response and 5V to 3.3V Conversion

The MIC29712 has excellent response to variations in input voltage and load current. By virtue of its low dropout voltage, this device does not saturate into dropout as readily as similar NPN-based designs. A 3.3V output Microchip LDO will maintain full speed and performance with an input supply as low as 4.2V, and will still provide some regulation with supplies down to 3.8V, unlike NPN devices that require 5.1V or more for good performance and become nothing more than a resistor under 4.6V of input. Microchip's PNP regulators provide superior performance in "5V to 3.3V" conversion applications, especially when all tolerances are considered.

4.4 Adjustable Regulator Design

The MIC29712 allows programming the output voltage anywhere between 1.25V and the 16V maximum operating rating. Two resistors are used. Resistors can be quite large, up to 100 kΩ, because of the very high input impedance and low bias current of the sense comparator. The resistor values are calculated using the following equation:

EQUATION 4-3:

$$R1 = R2 \times \left(\frac{V_{OUT}}{1.240} - 1 \right)$$

Where:

V_{OUT} = The desired output voltage.

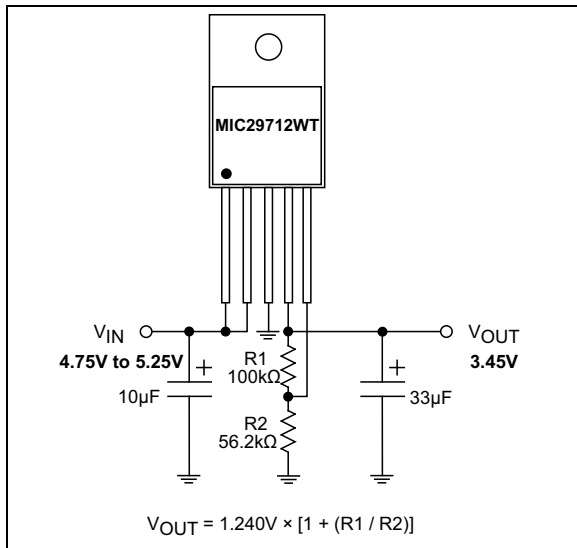

FIGURE 4-1: Adjustable Regulator with Resistors.

4.5 Enable Input

The MIC29712 features an enable (EN) input that allows ON/OFF control of the device. Special design allows "zero" current drain when the device is disabled—only micro-amperes of leakage current flows. The EN input has TTL/CMOS compatible thresholds for simple interfacing with logic, or may be directly tied to V_{IN} . Enabling the regulator requires approximately 20 µA of current into the EN pin.

4.6 Minimum Load Current

The MIC29712 is specified between finite loads. If the output current is too small, leakage currents dominate and the output voltage rises. A 10 mA minimum load current is necessary for proper regulation.

TABLE 4-1: MIC29712 RESISTOR VALUES

Voltage	R1	R2
2.85V	100 kΩ	76.8 kΩ
2.9V	100 kΩ	75 kΩ
3.0V	100 kΩ	69.8 kΩ
3.1V	100 kΩ	66.5 kΩ
3.15V	100 kΩ	64.9 kΩ
3.3V	100 kΩ	60.4 kΩ
3.45V	100 kΩ	56.2 kΩ
3.525V	93.1 kΩ	51.1 kΩ
3.6V	100 kΩ	52.3 kΩ
3.8V	100 kΩ	48.7 kΩ
4.0V	100 kΩ	45.3 kΩ
4.1V	100 kΩ	43.2 kΩ

5.0 PACKAGING INFORMATION

5.1 Package Marking Information

5-Lead TO-220*



Example



Legend:	XX...X	Product code or customer-specific information
	Y	Year code (last digit of calendar year)
	YY	Year code (last 2 digits of calendar year)
	WW	Week code (week of January 1 is week '01')
	NNN	Alphanumeric traceability code
	(e3)	Pb-free JEDEC® designator for Matte Tin (Sn)
	*	This package is Pb-free. The Pb-free JEDEC designator ((e3)) can be found on the outer packaging for this package.
	•, ▲, ▼	Pin one index is identified by a dot, delta up, or delta down (triangle mark).
Note:	In the event the full Microchip part number cannot be marked on one line, it will be carried over to the next line, thus limiting the number of available characters for customer-specific information. Package may or may not include the corporate logo.	
	Underbar () and/or Overbar () symbol may not be to scale.	

MIC29712

5-Lead TO-220 Package Outline & Recommended Land Pattern

TITLE

5 LEAD TO220 PACKAGE OUTLINE & RECOMMENDED LAND PATTERN

DRAWING #	TO220-5LD-PL-1	UNIT	INCH
Lead Frame	Copper Alloy	Lead Finish	Matte Tin

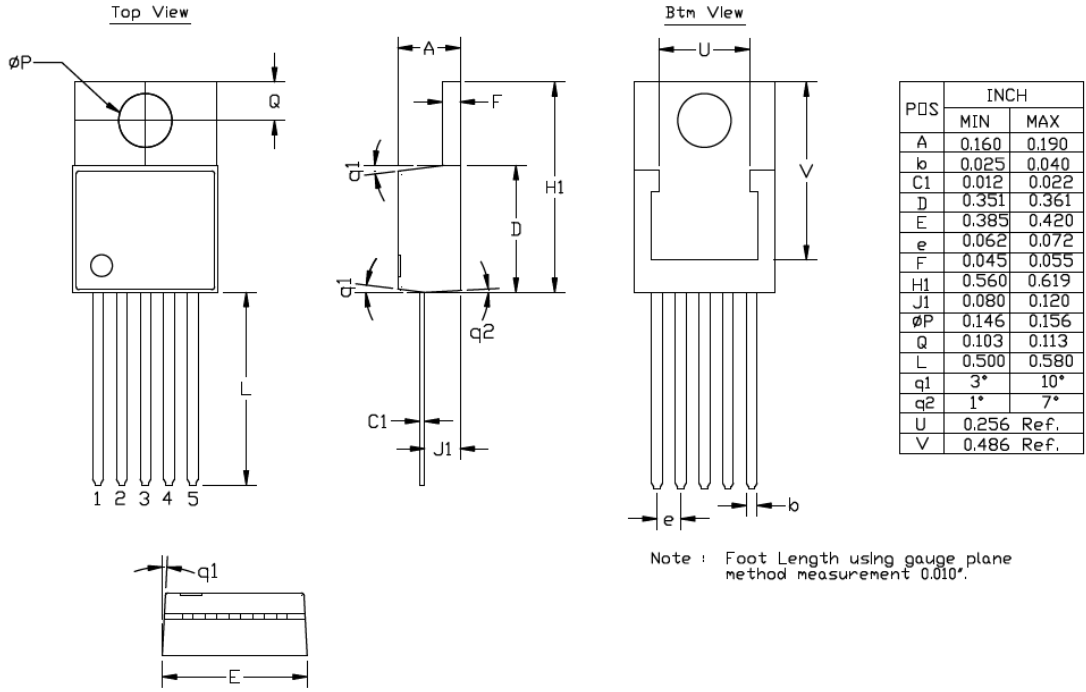

Note : Foot Length using gauge plane method measurement 0.010".

Note: For the most current package drawings, please see the Microchip Packaging Specification located at <http://www.microchip.com/packaging>.

APPENDIX A: REVISION HISTORY

Revision A (September 2018)

- Converted Micrel document MIC29712 to Microchip data sheet template DS20006068A.
- Minor grammatical text changes throughout.
- All reference to and information about the MIC29710 has been removed.

MIC29712

NOTES:

PRODUCT IDENTIFICATION SYSTEM

To order or obtain information, e.g., on pricing or delivery, contact your local Microchip representative or sales office.

Device	X	X	X	-XX
Part No.	Output Voltage	Junction Temp. Range	Package	Media Type
Device:	MIC29712:	7.5A Fast Response LDO Regulator		
Output Voltage:	<blank>= Adjustable			
Junction Temperature Range:	W	=	0°C to +125°C, RoHS-Compliant	
Package:	T	=	5-Lead TO-220	
Media Type:	<blank>= 50/Tube			

Examples:

a) MIC29712WT: MIC29712, Adjustable Output Voltage, 0°C to +125°C Temperature Range, 5-Lead TO-220, 50/Tube

Note 1: Tape and Reel identifier only appears in the catalog part number description. This identifier is used for ordering purposes and is not printed on the device package. Check with your Microchip Sales Office for package availability with the Tape and Reel option.

MIC29712

NOTES:

Note the following details of the code protection feature on Microchip devices:

- Microchip products meet the specification contained in their particular Microchip Data Sheet.
- Microchip believes that its family of products is one of the most secure families of its kind on the market today, when used in the intended manner and under normal conditions.
- There are dishonest and possibly illegal methods used to breach the code protection feature. All of these methods, to our knowledge, require using the Microchip products in a manner outside the operating specifications contained in Microchip's Data Sheets. Most likely, the person doing so is engaged in theft of intellectual property.
- Microchip is willing to work with the customer who is concerned about the integrity of their code.
- Neither Microchip nor any other semiconductor manufacturer can guarantee the security of their code. Code protection does not mean that we are guaranteeing the product as “unbreakable.”

Code protection is constantly evolving. We at Microchip are committed to continuously improving the code protection features of our products. Attempts to break Microchip's code protection feature may be a violation of the Digital Millennium Copyright Act. If such acts allow unauthorized access to your software or other copyrighted work, you may have a right to sue for relief under that Act.

Information contained in this publication regarding device applications and the like is provided only for your convenience and may be superseded by updates. It is your responsibility to ensure that your application meets with your specifications. MICROCHIP MAKES NO REPRESENTATIONS OR WARRANTIES OF ANY KIND WHETHER EXPRESS OR IMPLIED, WRITTEN OR ORAL, STATUTORY OR OTHERWISE, RELATED TO THE INFORMATION, INCLUDING BUT NOT LIMITED TO ITS CONDITION, QUALITY, PERFORMANCE, MERCHANTABILITY OR FITNESS FOR PURPOSE. Microchip disclaims all liability arising from this information and its use. Use of Microchip devices in life support and/or safety applications is entirely at the buyer's risk, and the buyer agrees to defend, indemnify and hold harmless Microchip from any and all damages, claims, suits, or expenses resulting from such use. No licenses are conveyed, implicitly or otherwise, under any Microchip intellectual property rights unless otherwise stated.

Microchip received ISO/TS-16949:2009 certification for its worldwide headquarters, design and wafer fabrication facilities in Chandler and Tempe, Arizona; Gresham, Oregon and design centers in California and India. The Company's quality system processes and procedures are for its PIC® MCUs and dsPIC® DSCs, KEELoc® code hopping devices, Serial EEPROMs, microperipherals, nonvolatile memory and analog products. In addition, Microchip's quality system for the design and manufacture of development systems is ISO 9001:2000 certified.

**QUALITY MANAGEMENT SYSTEM
CERTIFIED BY DNV
= ISO/TS 16949 =**

Trademarks

The Microchip name and logo, the Microchip logo, AnyRate, AVR, AVR logo, AVR Freaks, BitCloud, chipKIT, chipKIT logo, CryptoMemory, CryptoRF, dsPIC, FlashFlex, flexPWR, Helder, JukeBlox, KeeLoq, Klear, LANCheck, LINK MD, maXStylus, maXTouch, MediaLB, megaAVR, MOST, MOST logo, MPLAB, OptoLyzer, PIC, picoPower, PICSTART, PIC32 logo, Prochip Designer, QTouch, SAM-BA, SpyNIC, SST, SST Logo, SuperFlash, tinyAVR, UNI/O, and XMEGA are registered trademarks of Microchip Technology Incorporated in the U.S.A. and other countries.

ClockWorks, The Embedded Control Solutions Company, EtherSynch, Hyper Speed Control, HyperLight Load, IntellIMOS, mTouch, Precision Edge, and Quiet-Wire are registered trademarks of Microchip Technology Incorporated in the U.S.A.

Adjacent Key Suppression, AKS, Analog-for-the-Digital Age, Any Capacitor, AnyIn, AnyOut, BodyCom, CodeGuard, CryptoAuthentication, CryptoAutomotive, CryptoCompanion, CryptoController, dsPICDEM, dsPICDEM.net, Dynamic Average Matching, DAM, ECAN, EtherGREEN, In-Circuit Serial Programming, ICSP, INICnet, Inter-Chip Connectivity, JitterBlocker, KlearNet, KlearNet logo, memBrain, Mindi, MiWi, motorBench, MPASM, MPF, MPLAB Certified logo, MPLIB, MPLINK, MultiTRAK, NetDetach, Omniscient Code Generation, PICDEM, PICDEM.net, PICKit, PICtail, PowerSmart, PureSilicon, QMatrix, REAL ICE, Ripple Blocker, SAM-ICE, Serial Quad I/O, SMART-I.S., SQI, SuperSwitcher, SuperSwitcher II, Total Endurance, TSHARC, USBCheck, VariSense, ViewSpan, WiperLock, Wireless DNA, and ZENA are trademarks of Microchip Technology Incorporated in the U.S.A. and other countries.

SQTP is a service mark of Microchip Technology Incorporated in the U.S.A.

Silicon Storage Technology is a registered trademark of Microchip Technology Inc. in other countries.

GestIC is a registered trademark of Microchip Technology Germany II GmbH & Co. KG, a subsidiary of Microchip Technology Inc., in other countries.

All other trademarks mentioned herein are property of their respective companies.

© 2018, Microchip Technology Incorporated, All Rights Reserved.
ISBN: 978-1-5224-3484-9



MICROCHIP

Worldwide Sales and Service

AMERICAS

Corporate Office
2355 West Chandler Blvd.
Chandler, AZ 85224-6199
Tel: 480-792-7200
Fax: 480-792-7277
Technical Support:
<http://www.microchip.com/support>
Web Address:
www.microchip.com

Atlanta
Duluth, GA
Tel: 678-957-9614
Fax: 678-957-1455

Austin, TX
Tel: 512-257-3370

Boston
Westborough, MA
Tel: 774-760-0087
Fax: 774-760-0088

Chicago
Itasca, IL
Tel: 630-285-0071
Fax: 630-285-0075

Dallas
Addison, TX
Tel: 972-818-7423
Fax: 972-818-2924

Detroit
Novi, MI
Tel: 248-848-4000

Houston, TX
Tel: 281-894-5983

Indianapolis
Noblesville, IN
Tel: 317-773-8323
Fax: 317-773-5453
Tel: 317-536-2380

Los Angeles
Mission Viejo, CA
Tel: 949-462-9523
Fax: 949-462-9608
Tel: 951-273-7800

Raleigh, NC
Tel: 919-844-7510

New York, NY
Tel: 631-435-6000

San Jose, CA
Tel: 408-735-9110
Tel: 408-436-4270

Canada - Toronto
Tel: 905-695-1980
Fax: 905-695-2078

ASIA/PACIFIC

Australia - Sydney
Tel: 61-2-9868-6733

China - Beijing
Tel: 86-10-8569-7000

China - Chengdu
Tel: 86-28-8665-5511

China - Chongqing
Tel: 86-23-8980-9588

China - Dongguan
Tel: 86-769-8702-9880

China - Guangzhou
Tel: 86-20-8755-8029

China - Hangzhou
Tel: 86-571-8792-8115

China - Hong Kong SAR
Tel: 852-2943-5100

China - Nanjing
Tel: 86-25-8473-2460

China - Qingdao
Tel: 86-532-8502-7355

China - Shanghai
Tel: 86-21-3326-8000

China - Shenyang
Tel: 86-24-2334-2829

China - Shenzhen
Tel: 86-755-8864-2200

China - Suzhou
Tel: 86-186-6233-1526

China - Wuhan
Tel: 86-27-5980-5300

China - Xian
Tel: 86-29-8833-7252

China - Xiamen
Tel: 86-592-2388138

China - Zhuhai
Tel: 86-756-3210040

ASIA/PACIFIC

India - Bangalore
Tel: 91-80-3090-4444

India - New Delhi
Tel: 91-11-4160-8631

India - Pune
Tel: 91-20-4121-0141

Japan - Osaka
Tel: 81-6-6152-7160

Japan - Tokyo
Tel: 81-3-6880-3770

Korea - Daegu
Tel: 82-53-744-4301

Korea - Seoul
Tel: 82-2-554-7200

Malaysia - Kuala Lumpur
Tel: 60-3-7651-7906

Malaysia - Penang
Tel: 60-4-227-8870

Philippines - Manila
Tel: 63-2-634-9065

Singapore
Tel: 65-6334-8870

Taiwan - Hsin Chu
Tel: 886-3-577-8366

Taiwan - Kaohsiung
Tel: 886-7-213-7830

Taiwan - Taipei
Tel: 886-2-2508-8600

Thailand - Bangkok
Tel: 66-2-694-1351

Vietnam - Ho Chi Minh
Tel: 84-28-5448-2100

EUROPE

Austria - Wels
Tel: 43-7242-2244-39
Fax: 43-7242-2244-393

Denmark - Copenhagen
Tel: 45-4450-2828
Fax: 45-4485-2829

Finland - Espoo
Tel: 358-9-4520-820

France - Paris
Tel: 33-1-69-53-63-20
Fax: 33-1-69-30-90-79

Germany - Garching
Tel: 49-8931-9700

Germany - Haan
Tel: 49-2129-3766400

Germany - Heilbronn
Tel: 49-7131-67-3636

Germany - Karlsruhe
Tel: 49-721-625370

Germany - Munich
Tel: 49-89-627-144-0
Fax: 49-89-627-144-44

Germany - Rosenheim
Tel: 49-8031-354-560

Israel - Ra'anana
Tel: 972-9-744-7705

Italy - Milan
Tel: 39-0331-742611
Fax: 39-0331-466781

Italy - Padova
Tel: 39-049-7625286

Netherlands - Drunen
Tel: 31-416-690399
Fax: 31-416-690340

Norway - Trondheim
Tel: 47-7288-4388

Poland - Warsaw
Tel: 48-22-3325737

Romania - Bucharest
Tel: 40-21-407-87-50

Spain - Madrid
Tel: 34-91-708-08-90
Fax: 34-91-708-08-91

Sweden - Gothenberg
Tel: 46-31-704-60-40

Sweden - Stockholm
Tel: 46-8-5090-4654

UK - Wokingham
Tel: 44-118-921-5800
Fax: 44-118-921-5820