

5 kW low voltage high current inverter for automotive motor control applications



Features

- Low voltage, high current inverter kit with the following boards (not available separately)
- Power board with the following features:
 - insulated metal substrate (IMS) for efficient cooling
 - hosts 36 STH315N10F7 power MOSFETs in the H²PAK-6 (6 switch) package
 - Decoupling gate resistors (2.2 Ω)
 - 3-shunt resistors ground referred for current sensing (optional)
 - 3 NTCs for thermal protection
- Driver board with the following features:
 - Based on L9907 three phase gate driver AEC-Q100 qualified
 - 34-pin Motor Control connector
 - Full diagnostic via SPI
 - Current sense amplifiers
 - overvoltage, undervoltage and overcurrent with V_{DS} drop monitoring, overtemperature and shutdown
 - Programmable gate current capability
- Bulk capacitor board
- Current sensing board

Product summary	
5 kW low voltage high current inverter for automotive motor control applications	STEVAL-TTM001V1
automotive-grade N-channel 100 V, 2.1 mΩ typ., 180 A STripFET F7 Power MOSFET in H2PAK-2 and H2PAK-6 packages	STH315N10F7
automotive FET driver for 3 phase BLDC motors	L9907
Application	Automotive BLDC Motor

Description

The STEVAL-TTM001V1 evaluation kit is designed to demonstrate the highly efficient ST automotive-grade 100 V STripFET F7 series Power MOSFETs and BLDC motor driver IC operating in typical automotive low voltage (car battery up to 48 V), high current motor control applications.

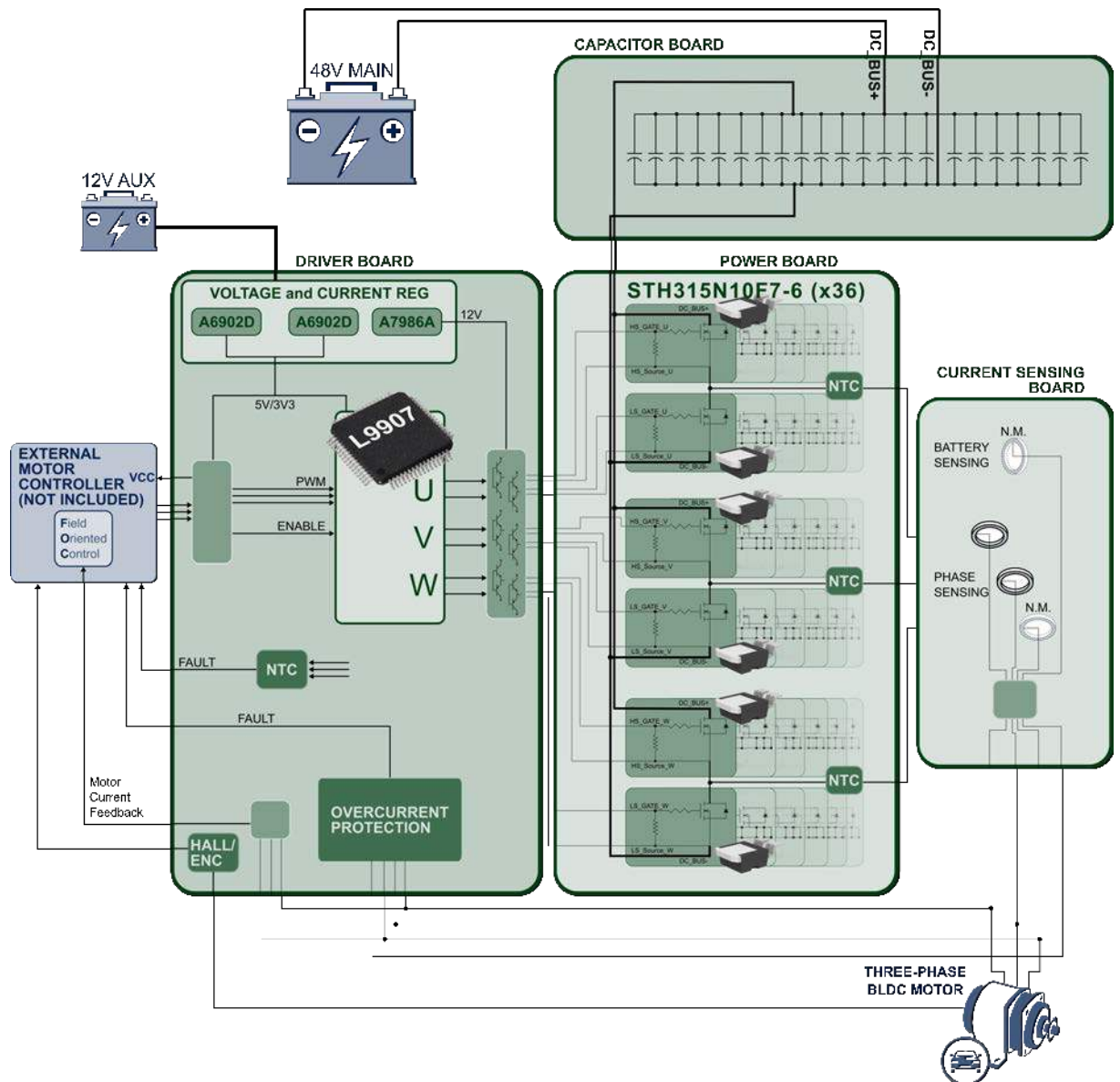
The kit has two boards to sense and condition currents and a driver board with a programmable L9907 FET driver with full diagnostics to manage all 36 STH315N10F7 Power MOSFETs on a separate power board also included in the kit.

The driver board also includes an ST motor control connector to interface with any compatible ST motor control board (not included in the kit), and various other connectors and jumpers for monitoring and protection, motor position feedback information, and auxiliary power.

1 Automotive motor control application overview

The STEVAL-TTM001V1 kit is designed to evaluate an inverter power stage for three-phase motors in automotive motor control applications, using automotive-grade components such as the [STH315N10F7](#) STripFET F7 series Power MOSFETs and the [L9907](#) automotive FET driver for 3 phase BLDC motors.

Figure 1. Block diagram for automotive motor control applications



The 48 V_{DC} power source representing the motor vehicle battery is connected to the capacitor board, which rectifies ripple current and minimizes unwanted interference to motor positioning feedback signals. The positive line of the battery can also be set up to be monitored by a current sensor (not mounted) on the kit current sensing board.

The single L9907 automotive gate driver on the driver board receives PWM signals from an external motor control board (not included in kit) to drive all the high side and low side MOSFETs on the power board. The driver board also processes current level signals from the hall effect sensors on the current sensing board and temperature signals from the NTC thermistors on the power board, and sends appropriate signals to the external motor control board.

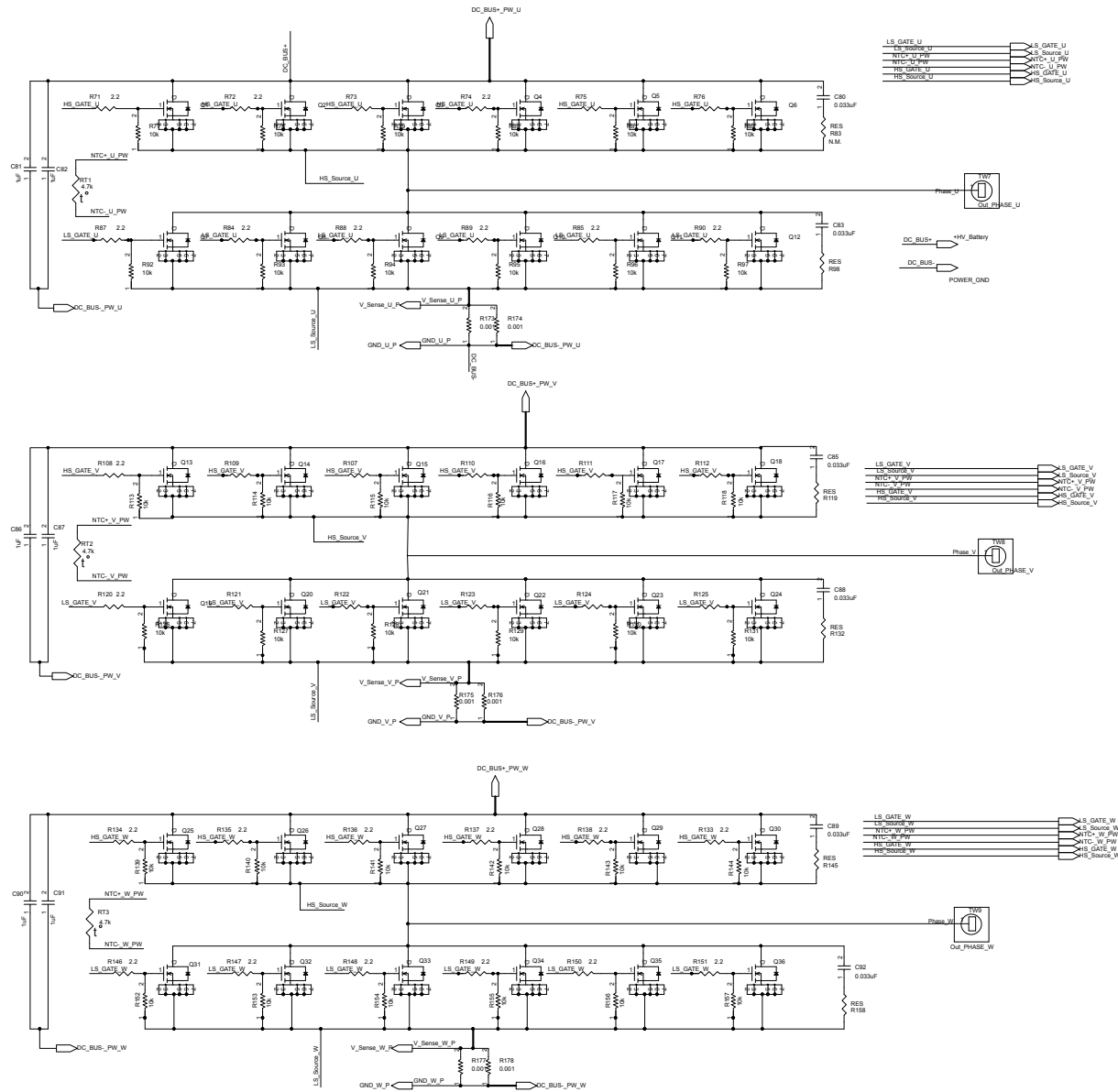
The power board mounts six high side and six low side [STH315N10F7](#) N-channel 100 V, 2.1 m Ω typ., 180 A MOSFETs for each phase (U,V and W) of a BLDC motor on an insulated metal substrate (IMS) for superior heat dissipation. The NTC thermistors are placed as close as possible to the MOSFET arrays for each phase output to provide relevant thermal feedback information. Finally, decoupling gate resistors are placed on each power MOSFET.

RELATED LINKS

[Visit the ST application page for more information on Automotive BLDC motor control](#)

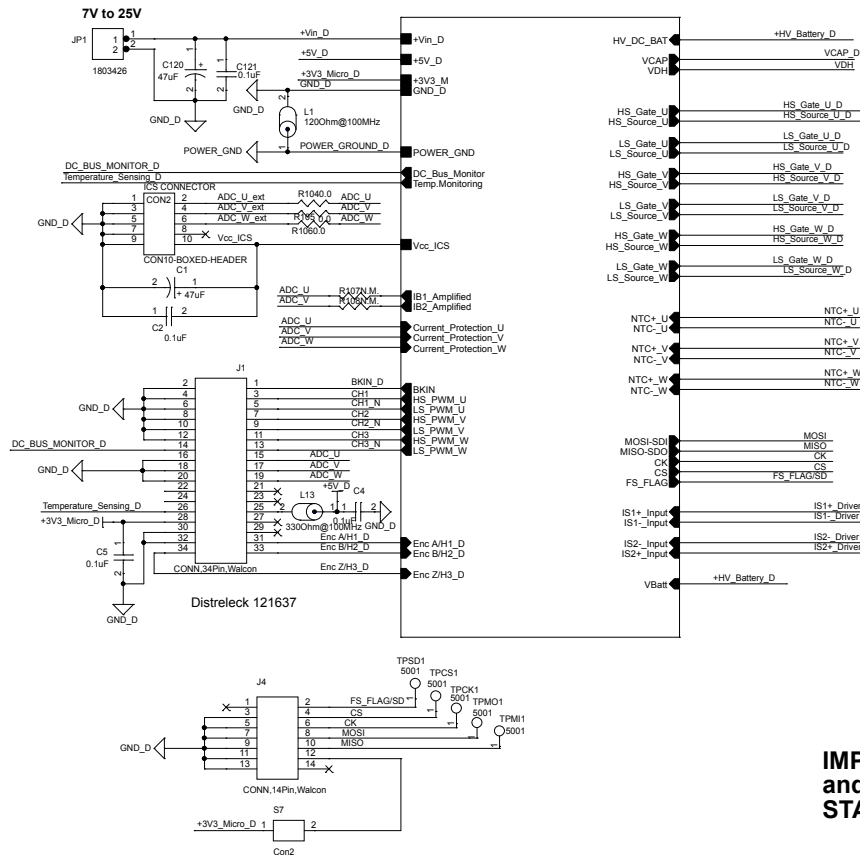
2 Power board schematic diagrams

Figure 2. Power board schematics

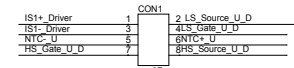


4 Driver board schematic diagrams

Figure 4. Driver board schematics - main with connectors

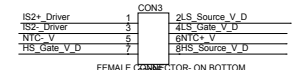


Connectors for POWER STAGE



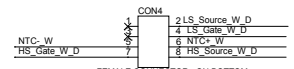
CON1F

FEMALE CONNECTOR - ON BOTTOM



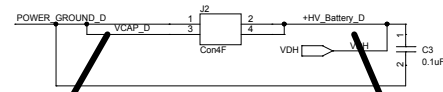
CON3F

FEMALE CONNECTOR - ON BOTTOM



CON4F

FEMALE CONNECTOR - ON BOTTOM



CON2F

FEMALE CONNECTOR - ON BOTTOM

to be CONNECTED to the POWER GROUND in the POWER STAGE - CHECK on POWER STAGE

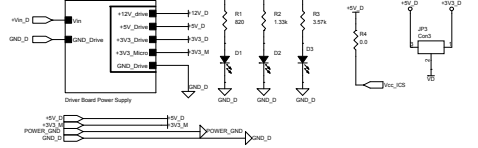
to be CONNECTED to + VBATT in the POWER STAGE - CHECK on POWER STAGE

IMPORTANT: TO BE PLUGGED according to TOP and BOTTOM-TO BE CONNECTED to the IMS POWER STAGE

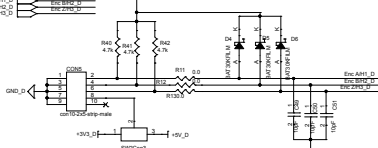


Figure 5. Driver board schematics - sensing and status

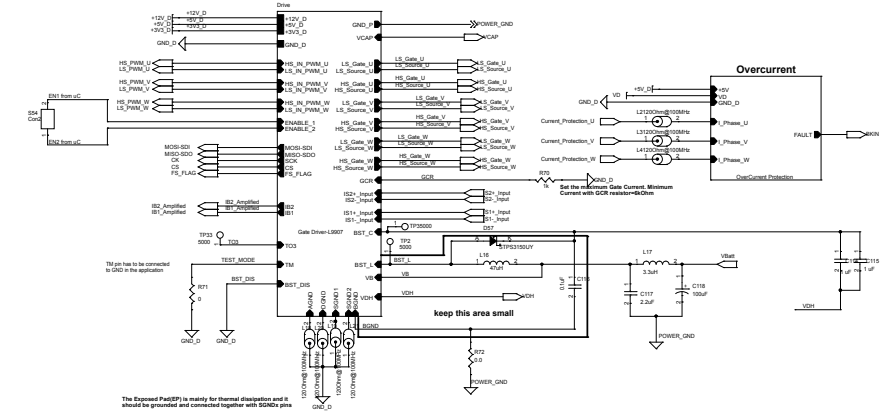
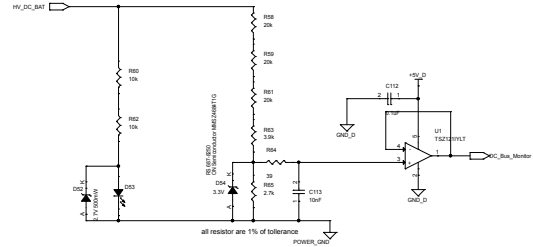
Driver Board Power Supply and LED Indicators



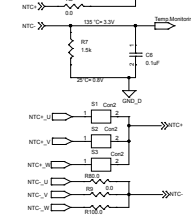
HALL/ENCODER CONNECTOR



Bus voltage sensing



NTC



The Exposed Pad(EPP) is mainly for thermal dissipation and it should be grounded and connected together with SMDs pins



Figure 6. Driver board schematics - gate driver section

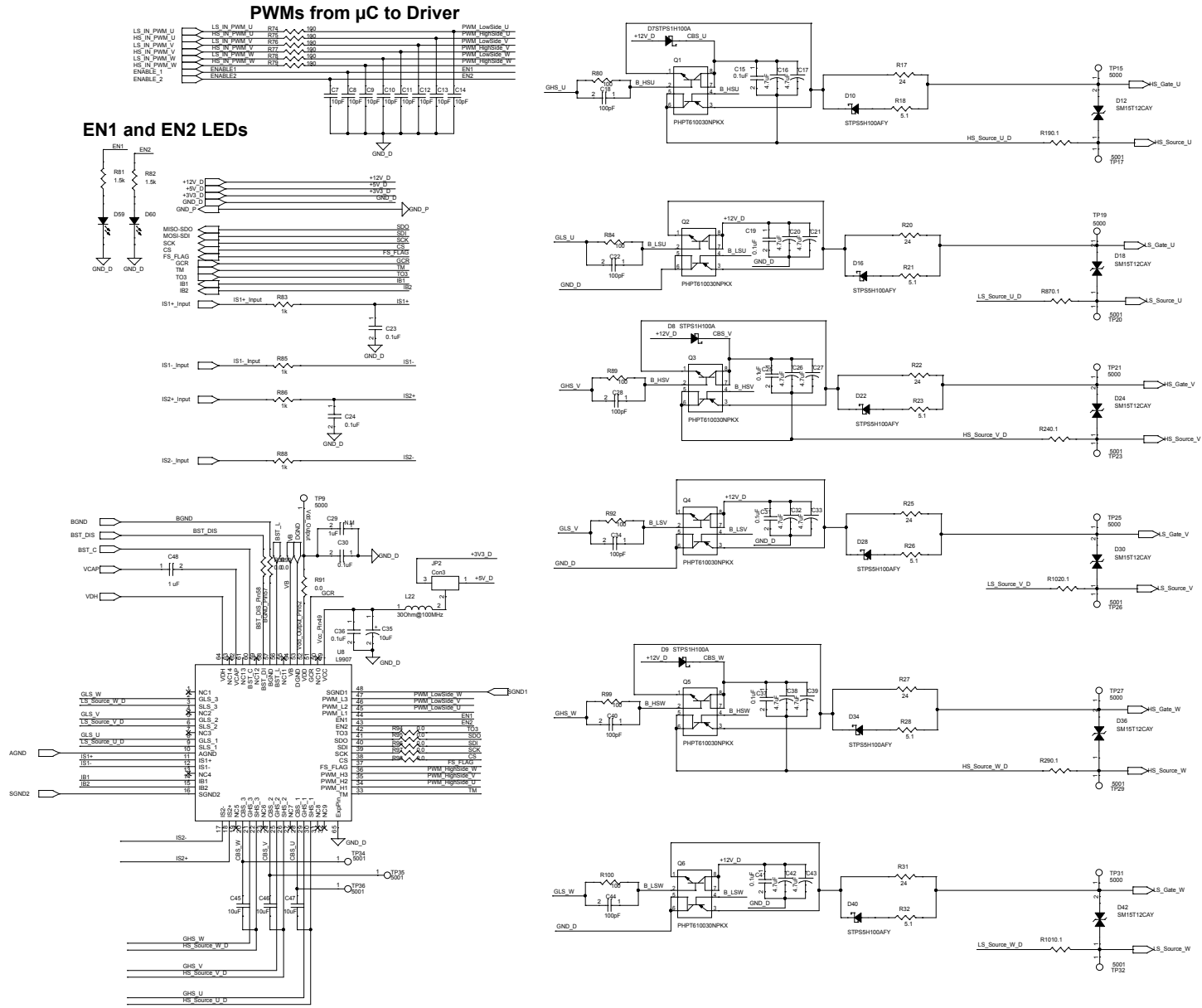


Figure 7. Driver board schematics - overcurrent protection

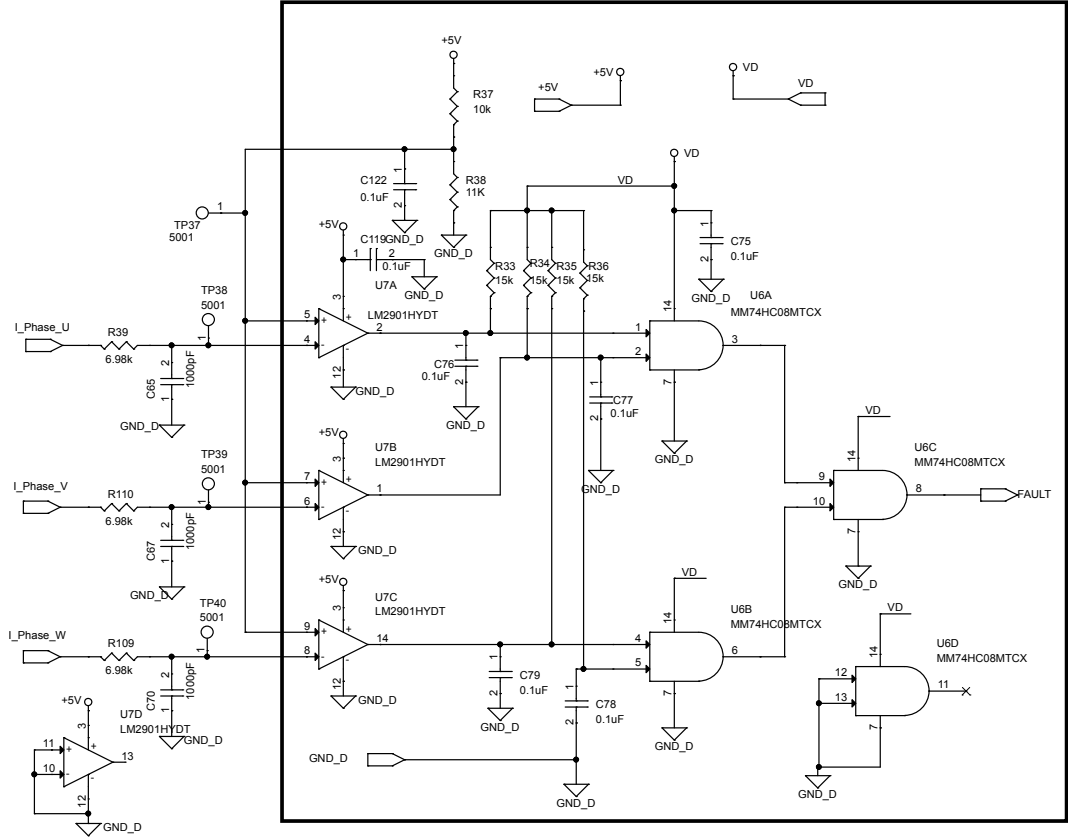
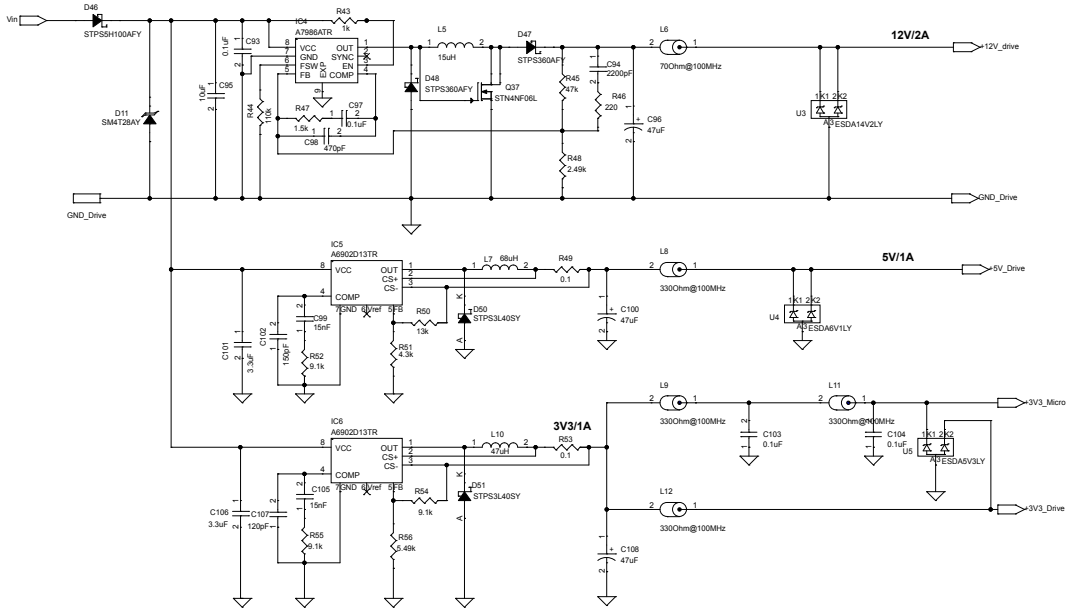
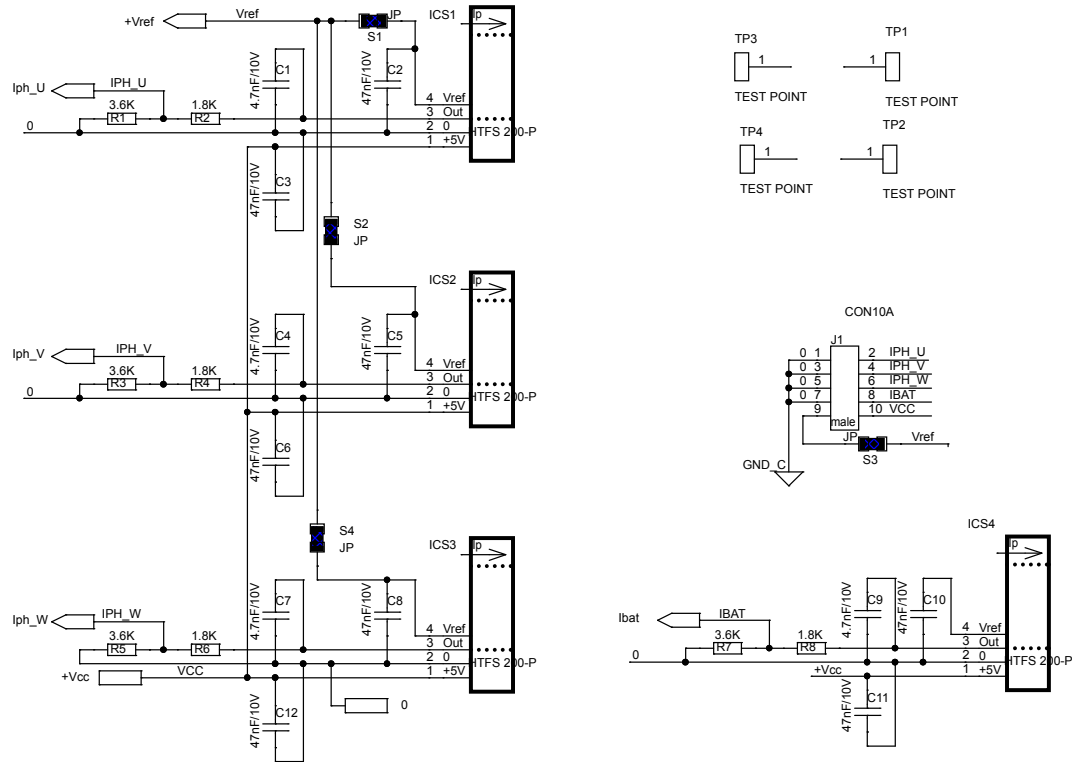


Figure 8. Driver board schematics - power supply



5 Current sensor board schematic diagrams

Figure 9. Current sensor board schematics



Revision history

Table 1. Document revision history

Date	Version	Changes
04-Sep-2019	1	Initial release.

IMPORTANT NOTICE – PLEASE READ CAREFULLY

STMicroelectronics NV and its subsidiaries (“ST”) reserve the right to make changes, corrections, enhancements, modifications, and improvements to ST products and/or to this document at any time without notice. Purchasers should obtain the latest relevant information on ST products before placing orders. ST products are sold pursuant to ST’s terms and conditions of sale in place at the time of order acknowledgement.

Purchasers are solely responsible for the choice, selection, and use of ST products and ST assumes no liability for application assistance or the design of Purchasers’ products.

No license, express or implied, to any intellectual property right is granted by ST herein.

Resale of ST products with provisions different from the information set forth herein shall void any warranty granted by ST for such product.

ST and the ST logo are trademarks of ST. For additional information about ST trademarks, please refer to www.st.com/trademarks. All other product or service names are the property of their respective owners.

Information in this document supersedes and replaces information previously supplied in any prior versions of this document.

© 2019 STMicroelectronics – All rights reserved