

Selection Guide

By V_{CES}

V_{CES} (V)	I_c (A)	P_c (W)	Part Number	Package
330	20	35	FGT312	TO220F(FM20)
330	30	35	FGT313	TO220F(FM20)
400	20	35	FGT412	TO220F(FM20)
600	20	35	FGT612	TO220F(FM20)
600	25	60	FGM622S	TO3PF(FM100)
600	30	60	FGM603	TO3PF(FM100)
600	30	60	FGM623S	TO3PF(FM100)
600	50	150	MGD623N	TO3P(MT100)
600	50	150	MGD623S	TO3P(MT100)

Specifications List by Part Number

Part Number	Absolute Maximum Ratings (Ta=25°C)					Electrical Characteristics																	
	V _{CES} (V)	V _{GE} (V)	I _c (A)	I _{c(pulse)} (A)	P _c (Ta=25°C) (W)	I _{GES}		I _{CES}		V _{GE(th)}				V _{CE(sat)}				C _{ies}		C _{oes}		C _{res}	
						Conditions	Conditions	Conditions	Conditions	Conditions	Conditions	Conditions	Conditions	Conditions	Conditions	Conditions	Conditions	Conditions	Conditions	Conditions			
	(nA)	V _{GE} (V)	(μA)	V _{CE} (V)	(V)	I _c (mA)	V _{CE} (V)	(V)	I _c (A)	V _{GE} (V)	(pF)	(pF)	(pF)	V _{CE} (V)	V _{GE} (V)								
FGM603	600	±20	30	90	60	±100	±20	100	600	4	7	1	10	1.6	2.0	30	15	4600	110	80	20	0	
FGM622S	600	±30	25	75	60	±500	±30	100	600	4	7	1	10	1.7	1.9	25	15	1300	80	40	20	0	
FGM623S	600	±30	30	100	60	±500	±30	100	600	3	6	1	10	1.5	1.7	30	15	2500	150	80	20	0	
FGT312	330	±30	20	120	35	±100	±30	100	330	3	6	1	10	1.3	1.7	20	15	1200	130	65	20	0	
FGT313	330	±30	30	200	35	±100	±30	100	330	3	6	1	10	1.3	1.7	30	15	2400	110	60	30	0	
FGT412	400	±30	20	120	35	±100	±30	100	400	3	6	1	10	1.4	1.8	20	15	1200	120	65	20	0	
FGT612	600	±30	20	120	35	±100	±30	100	600	3	6	1	10	1.6	2.0	20	15	1200	80	40	20	0	
MGD623N	600	±30	50	100	150	±100	±30	100	600	3	6	1	10	1.7	2.3	50	15	2500	150	80	20	0	
MGD623S	600	±30	50	100	150	±100	±30	100	600	3	6	1	10	1.8	2.4	50	15	2500	150	80	20	0	

Electrical Characteristics (Ta=25°C)																				Package	Mass (g)	
td(on)	tr	td(off)	tf	Conditions			Qg	Qge	Qgc	Conditions			VF		trr	Conditions						
(ns)	(ns)	(ns)	(ns)	Ic	VCE		(nC)	(nC)	(nC)	Ic	VCE	VGE	(V)			I _F	(μs)	I _F	di/dt			
typ	typ	typ	typ	(A)	(V)		typ	typ	typ	(A)	(V)	(V)	typ	max	(A)	typ	(A)	(A/μs)				
130	70	340	200	30	300	L Load	120	30	30	30	300	15								TO3PF(FM100)	6.5	
50	60	200	120	25	300	L Load	40	10	10	25	300	15								TO3PF(FM100)	6.5	
100	80	300	120	30	300	L Load	65	20	20	30	300	15								TO3PF(FM100)	6.5	
15	30	55	210	20	150	R Load	35	8	10	20	150	15								TO220F(FM20)	2.0	
20	90	90	180	60	250	R Load	65	10	20	60	250	15								TO220F(FM20)	2.0	
15	35	55	220	20	200	R Load	35	8	10	20	200	15								TO220F(FM20)	2.0	
25	60	70	190	20	300	R Load	35	6	9	20	300	15								TO220F(FM20)	2.0	
75	70	250	200	50	300	L Load	65	15	20	50	300	15	1.2	1.6	30	0.3	30	100		TO3P(MT100)	6.0	Built-in Di
75	70	250	120	50	300	L Load	65	15	20	50	300	15	1.2	1.6	30	0.3	30	100		TO3P(MT100)	6.0	Built-in Di

Package Type (Dimensions)

• TO-220F (FM20)

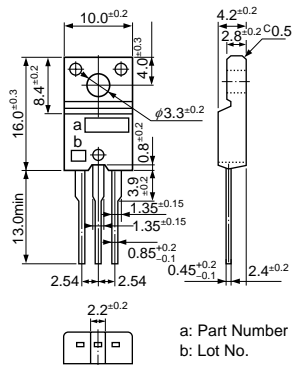

• TO-220 (MT-25)

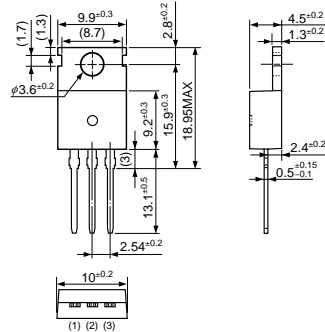

• TO-3P (MT-100)

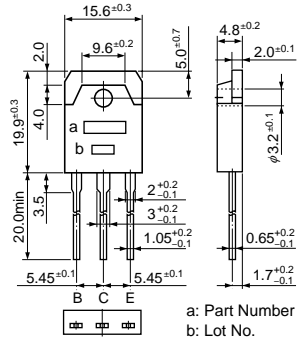

• TO-3PF (FM100)

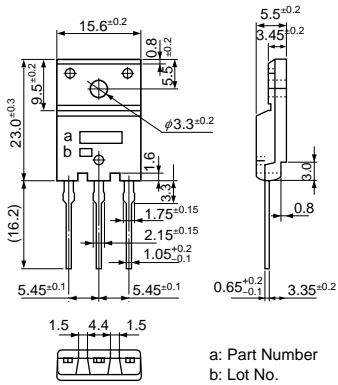

• MT-200

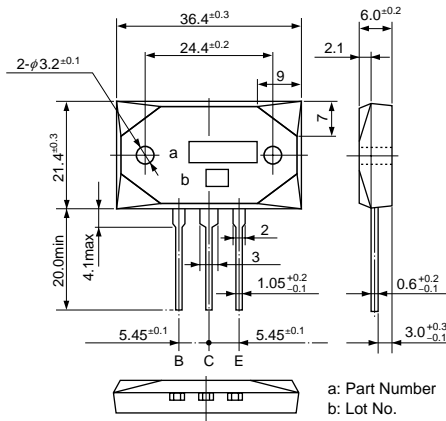

• TO-220S

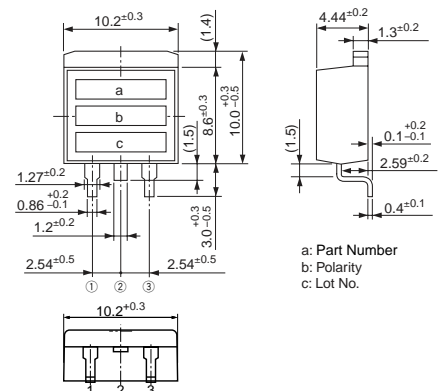

• TO-263

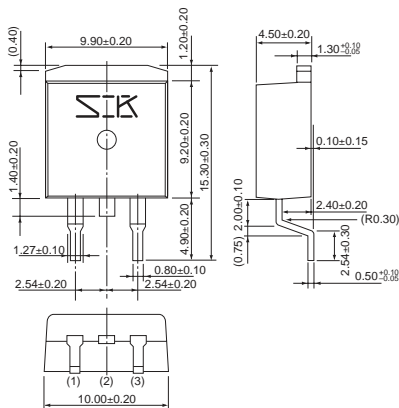

• TO3P-5Pin
NPN

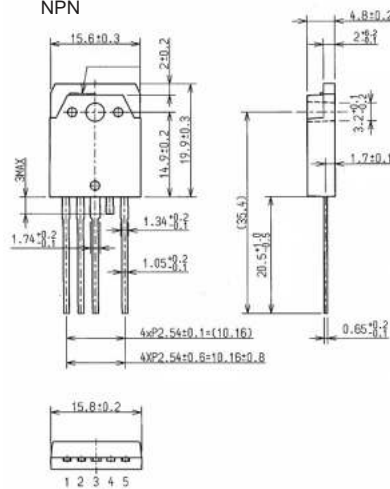

PNP

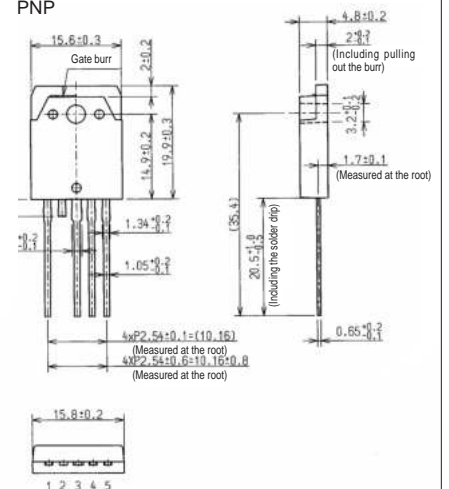

(Unit : mm)