

# 3M™ TEXTTOOL™ OPEN-TOP SOCKETS FOR QFN APPLICATIONS

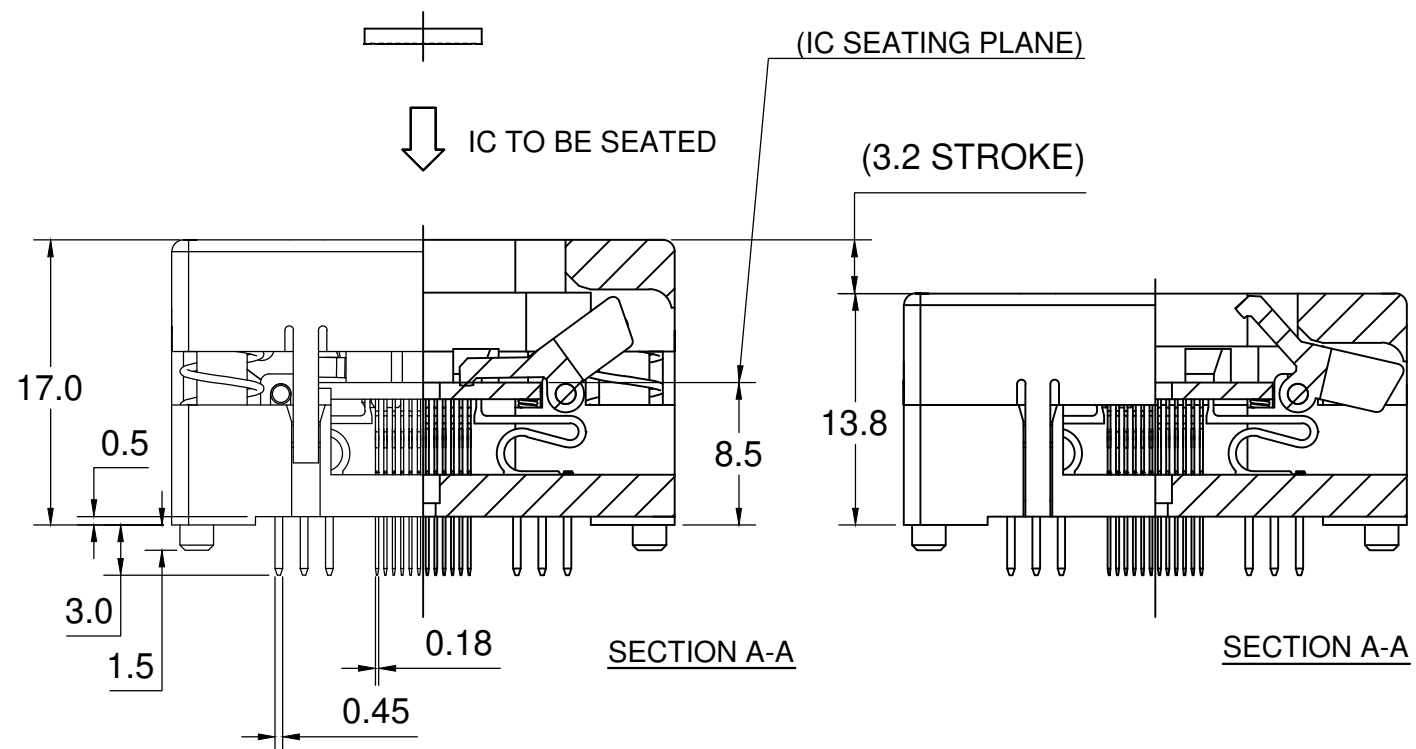
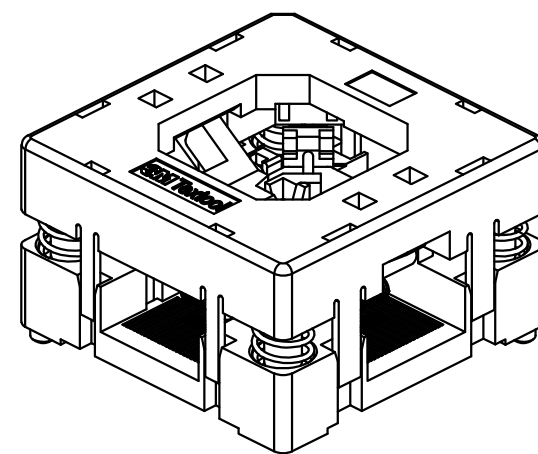
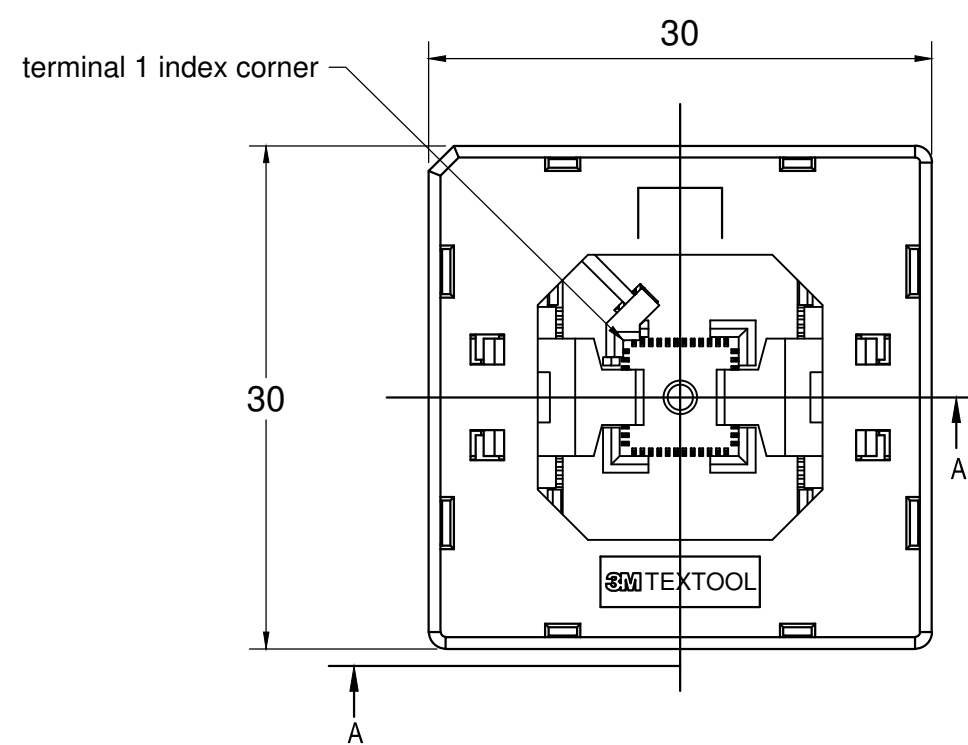

## NOTES:

### 1. MATERIALS:

SPRINGS	SS	PLATING : Au
CONTACTS	Be Cu	COLOR : BLACK
IC GUIDES	PES	COLOR : BLACK
PRESSURE PAD	PES	COLOR : BLACK
COVER	PPS or equiv.	COLOR : BLACK
BASE	PES	COLOR : BLACK

2. SEE THE REGULATORY INFORMATION APPENDIX (RIA) IN THE "RoHS COMPLIANCE" SECTION [WWW.3MCONNECTOR.COM](http://WWW.3MCONNECTOR.COM) FOR COMPLIANCE INFORMATION (RIA E1 & C1 APPLY).

3. FOR PRODUCT SPECIFICATIONS AND WARRANTY INFORMATION SEE:

[WWW.3MCONNECTOR.COM](http://WWW.3MCONNECTOR.COM) PN 248-5205-00

DRAWING NUMBER  
78-5100-2471-0

REVISION  
A

DESIGN REFERENCE		NEXT ASSEMBLY		A   37213   INITIAL RELEASE		ARM	
DISTRIBUTION CODES		SCALE		TOLERANCES EXCEPT AS NOTED		3M Center St. Paul, MN 55144 © 3M COPYRIGHT 2012 This document is the copyrighted property of the 3M Company and may not be reproduced without 3M written permission or used for other than 3M authorized purposes.	
DO NOT SCALE DRAWING		SCALE 5/1		INCHES		QFN TEST SOCKET, 0.5mm 48 pos, EVEN ROW, 7x7 PKG NO TP	
THIRD ANGLE PROJECTION		INTERPRET PER ASME Y14.5 - 1994		MILLIMETERS		CAGE NUMBER <b>C</b> SIZE <b>C</b> DRAWING NO. <b>78-5100-2471-0</b> REV. <b>A</b>	
MAX SURFACE ROUGHNESS 125		<input type="checkbox"/> ALL SURFACES <input checked="" type="checkbox"/> MARKED ONLY		INCHES: .0 ± .1, .00 ± .02, .000 ± .005, .0000 ± .0002 MILLIMETERS: 0 ± .1, .0 ± .05, .00 ± .002		MODEL TEXTTOOL - QFN DET. LISTS <input type="checkbox"/> YES <input checked="" type="checkbox"/> NO SHT 1 OF 2	
DRFT DATE MFG DATE CHKD DATE APPVL DATE		REV ECO ISSUE DATE AND DESCRIPTION DRFT DATE MFG DATE CHKD DATE APPVL DATE		ANGLS ± 1°		TITLE QFN TEST SOCKET, 0.5mm 48 pos, EVEN ROW, 7x7 PKG NO TP	

# 3M™ TEXTTOOL™ OPEN-TOP SOCKETS FOR QFN APPLICATIONS

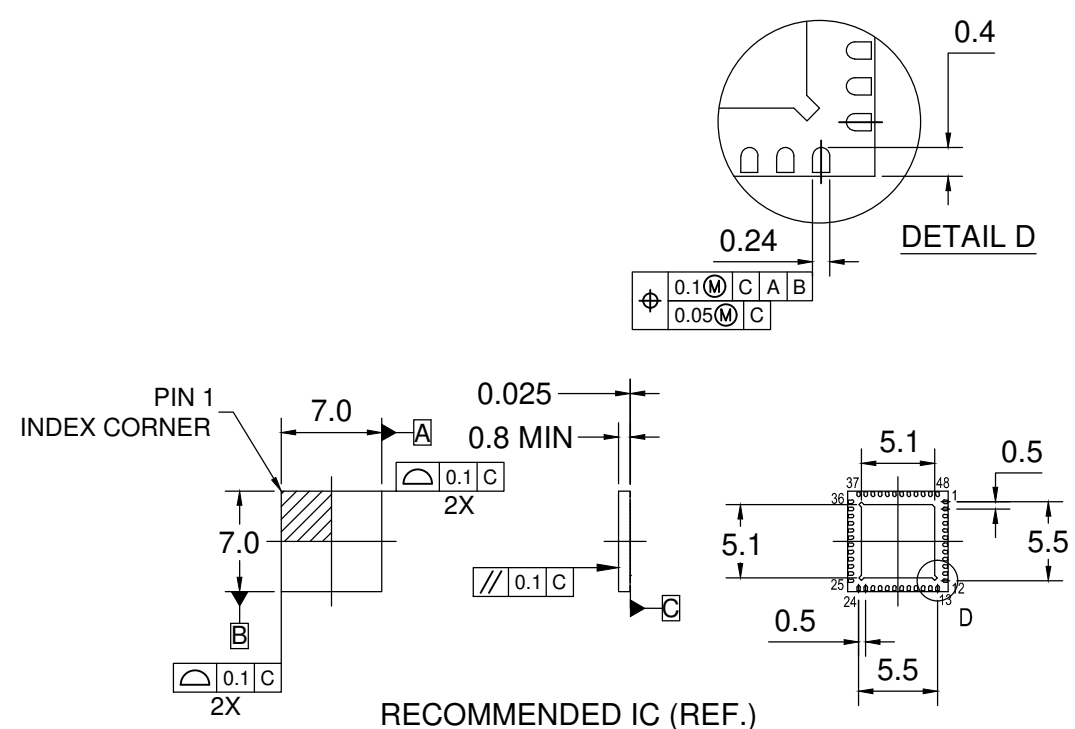
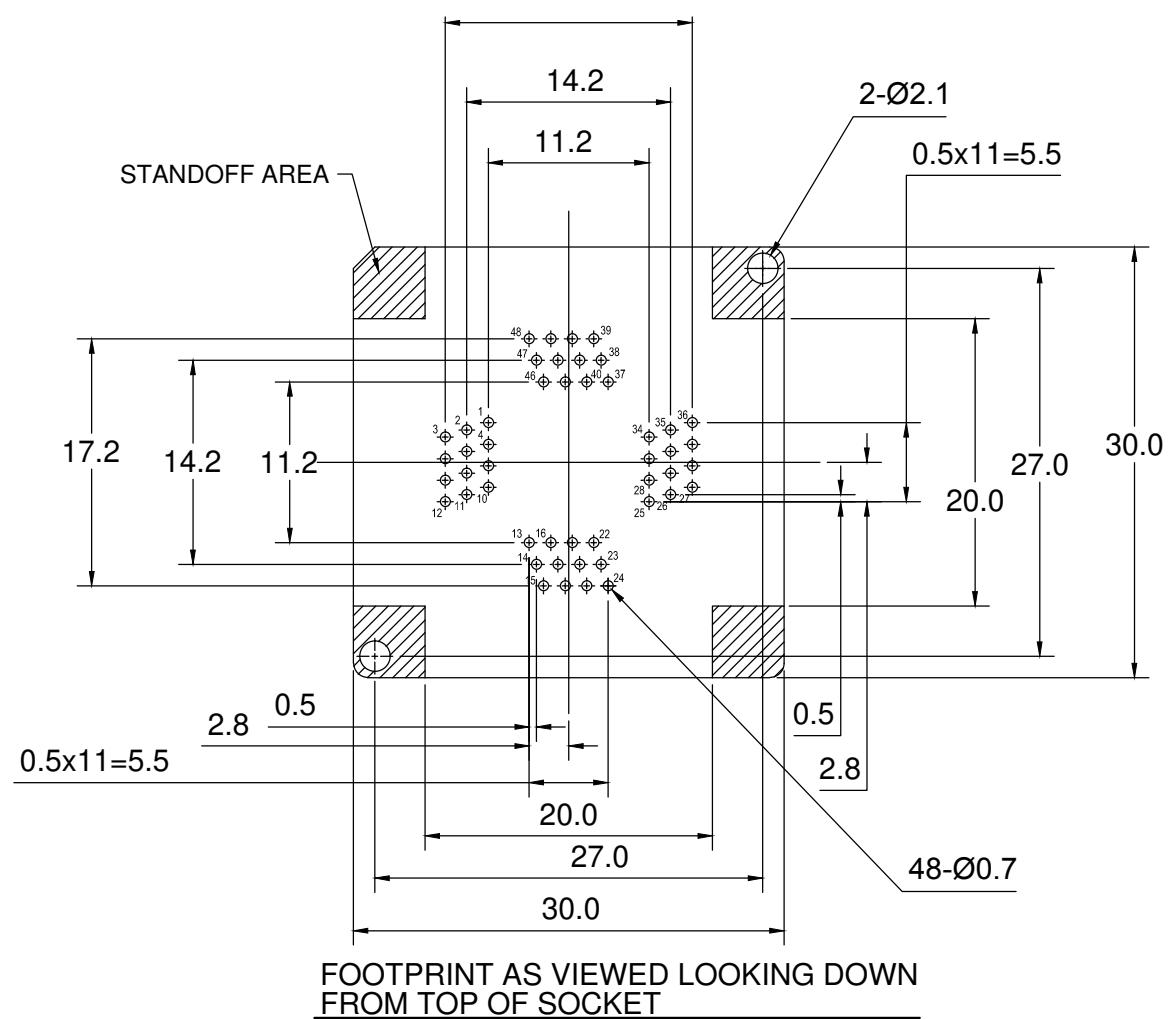

DESIGN REFERENCE	NEXT ASSEMBLY	REV	ECO	ISSUE DATE AND DESCRIPTION	DRFT	CHKD
DISTRIBUTION CODES		DRFT		DATE	MFG	DATE
		CHKD		DATE	APPVL	DATE
DIVISION	DIVISION CODE	3M		3M Center St. Paul, MN 55144	© 3M COPYRIGHT 2012 This document is the copyrighted property of the 3M Company and may not be reproduced without 3M written permission or used for other than 3M authorized purposes.	
DO NOT SCALE DRAWING	SCALE 5 1	TOLERANCES EXCEPT AS NOTED		TITLE QFN TEST SOCKET, 0.5mm 48 pos, EVEN ROW, 7x7 PKG NO TP		
THIRD ANGLE PROJECTION	INTERPRET PER ASME Y14.5 - 1994	INCHES .0 ± .1 .00 ± .02 .000 ± .005 .0000 ± .0002		CAGE NUMBER 78-5100-2471-0		
MAX SURFACE ROUGHNESS 125	<input type="checkbox"/> ALL SURFACES <input checked="" type="checkbox"/> MARKED ONLY	MILLIMETERS 0 ± .1 .0 ± .005 .000 ± .0002		DRAWING NO. 78-5100-2471-0		REV. A
		ANGLES ± 1°		MODEL TEXTTOOL - QFN		DET. LISTS <input type="checkbox"/> YES <input checked="" type="checkbox"/> NO
				SHT 2 OF 2		