

LOC		DIST		REVISIONS			
P	LTN	DESCRIPTION	DATE	DMN	APVD		
H2	ECR-12-013691		02AUG2012	GB	SzG		
H3	ECR-15-002210		05MAR2015	GB	SzG		
H4	ECR-16-009474		21JUL2016	LSZ	GB		
H5	ECR-20-010381		10DEC2021	KMD	MN		

-4 wie gezeichnet
AS SHOWN

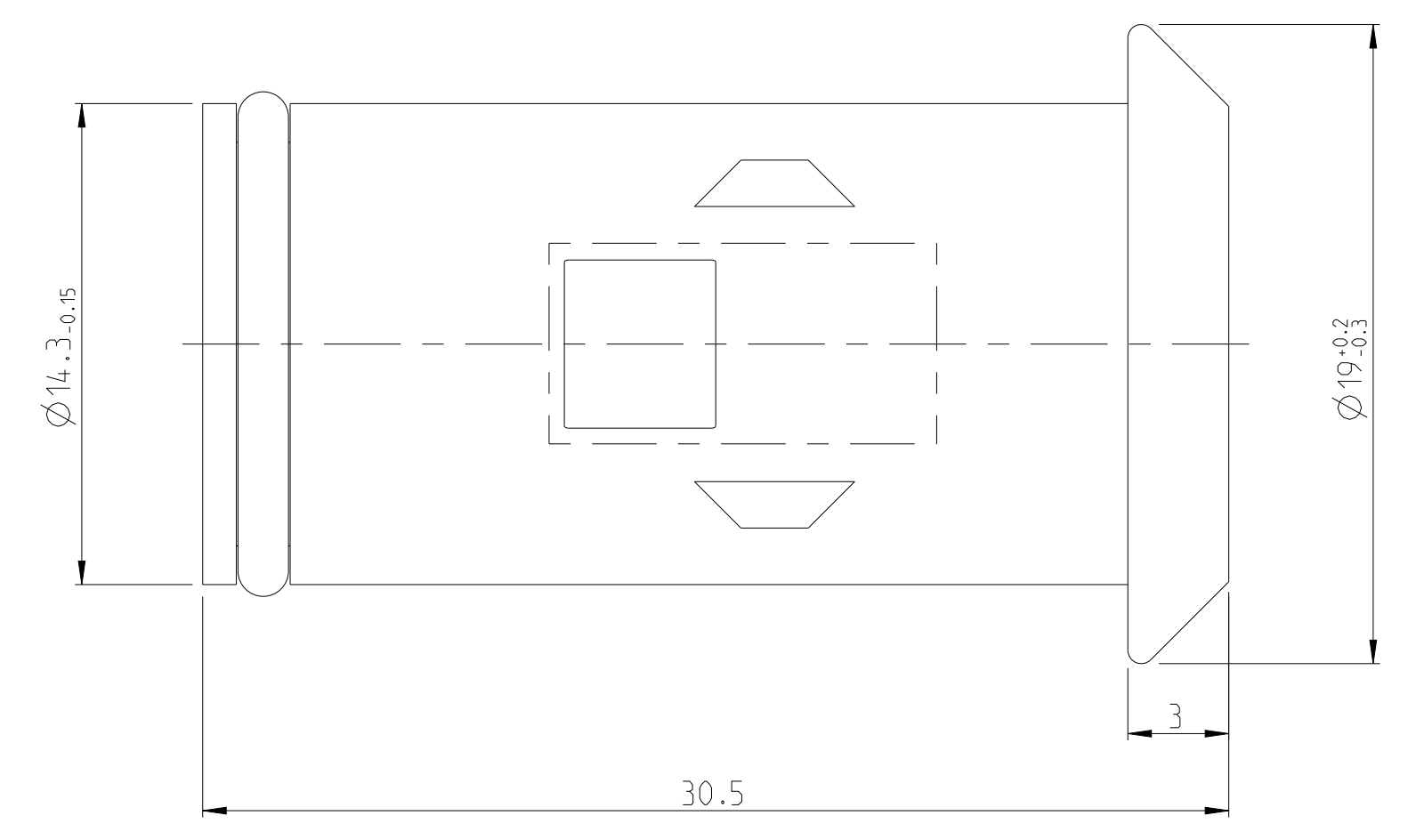
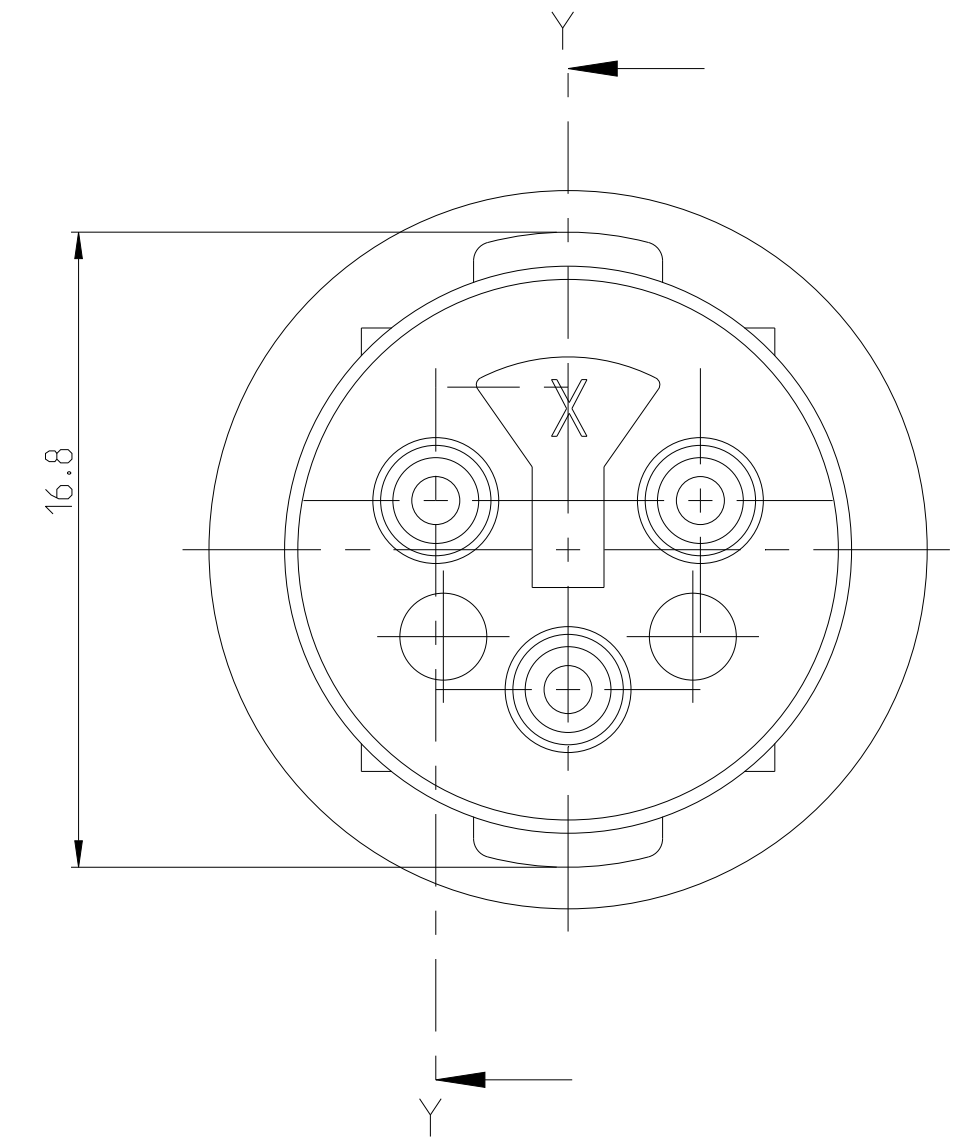
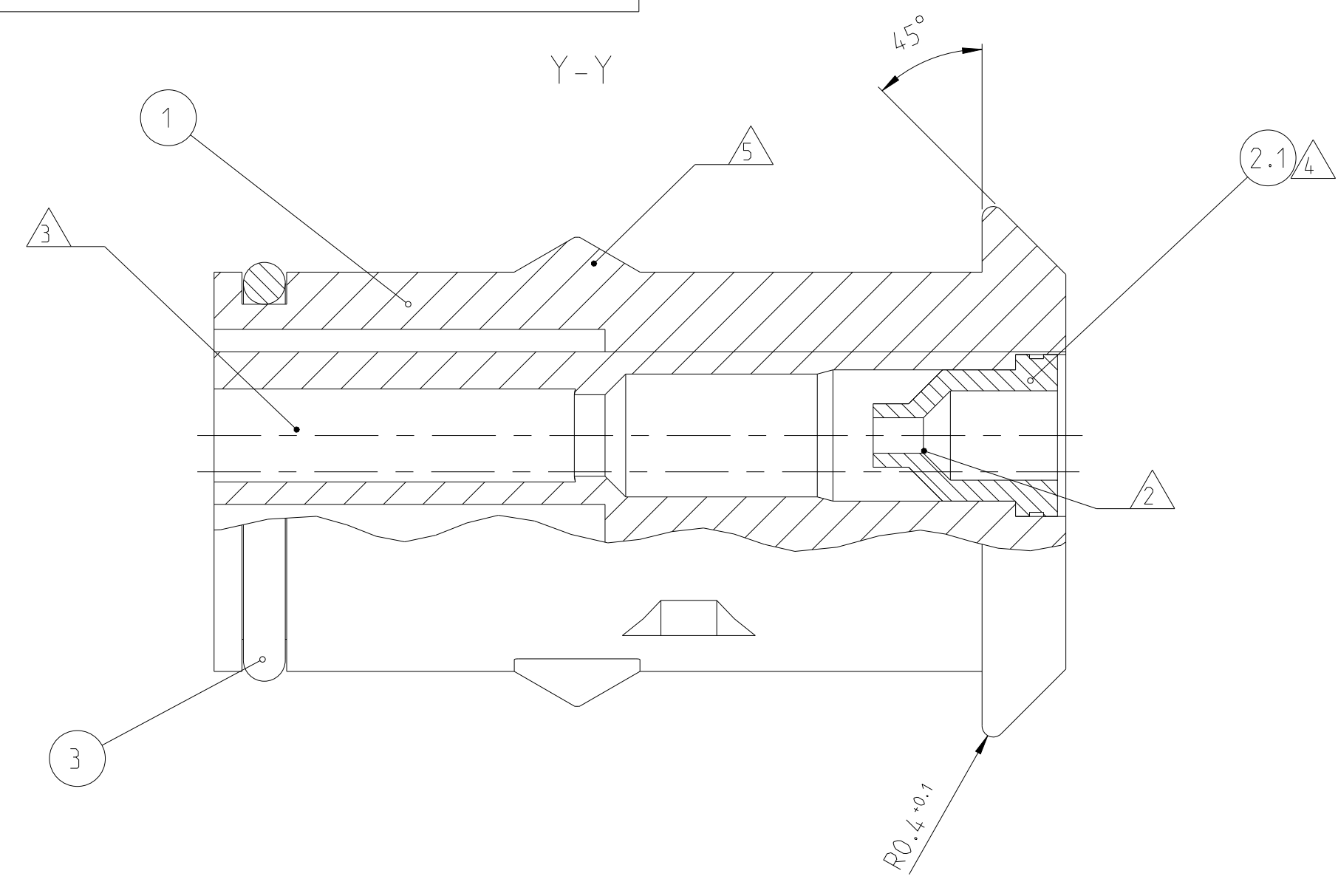

H2 H3

Bemerkungen / Notes:

- Teile in Lupolenbeutel luftdicht verpackt (500/1000 Sctk.)
Parts must be airtight packaged in bags of lupolen (500/1000 pieces)
- Geschmiert mit Gleitmittel Hellerine (Fa. Hellermannlyton) direkt vor dem Einsetzen des Kontaktes
Lubricated with Hellerine 625 (Hellermannlyton) right before contact insertion
- Kammer für Buschsenkontakt CIC. C1-2 od. Type III
Cavity for socket contact CIC. C1-2 or Type III
- Dichtungstülle für Litzenleitung mit Isolationsdurchmesser von 2.3-3.0mm
Seal for wire with isolationdiameter 2.3 - 3.0 mm
- Dichtungstülle für Litzenleitung mit Isolationsdurchmesser von 1.3-2.3 mm
Seal for wire with isolationdiameter 1.3 - 2.3 mm
- Keying Form with the Mating Connector: Click Stop
- Keying Form with the Mating Connector: Locking

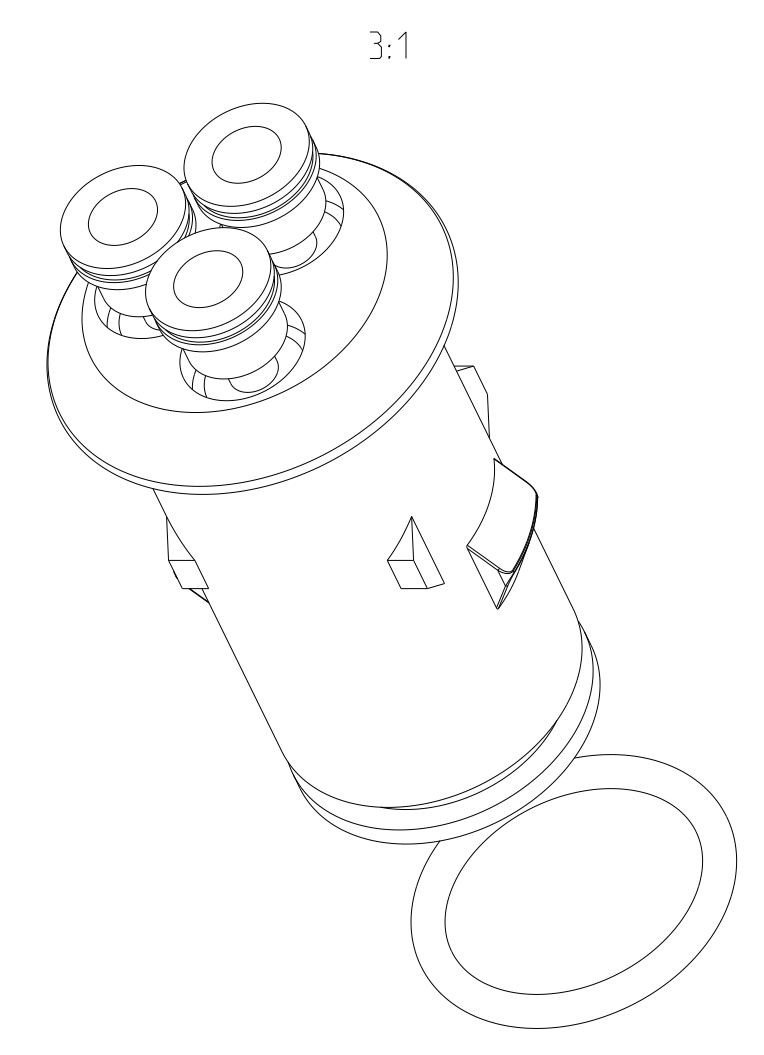

1-...-2 wie gezeichnet
AS SHOWN

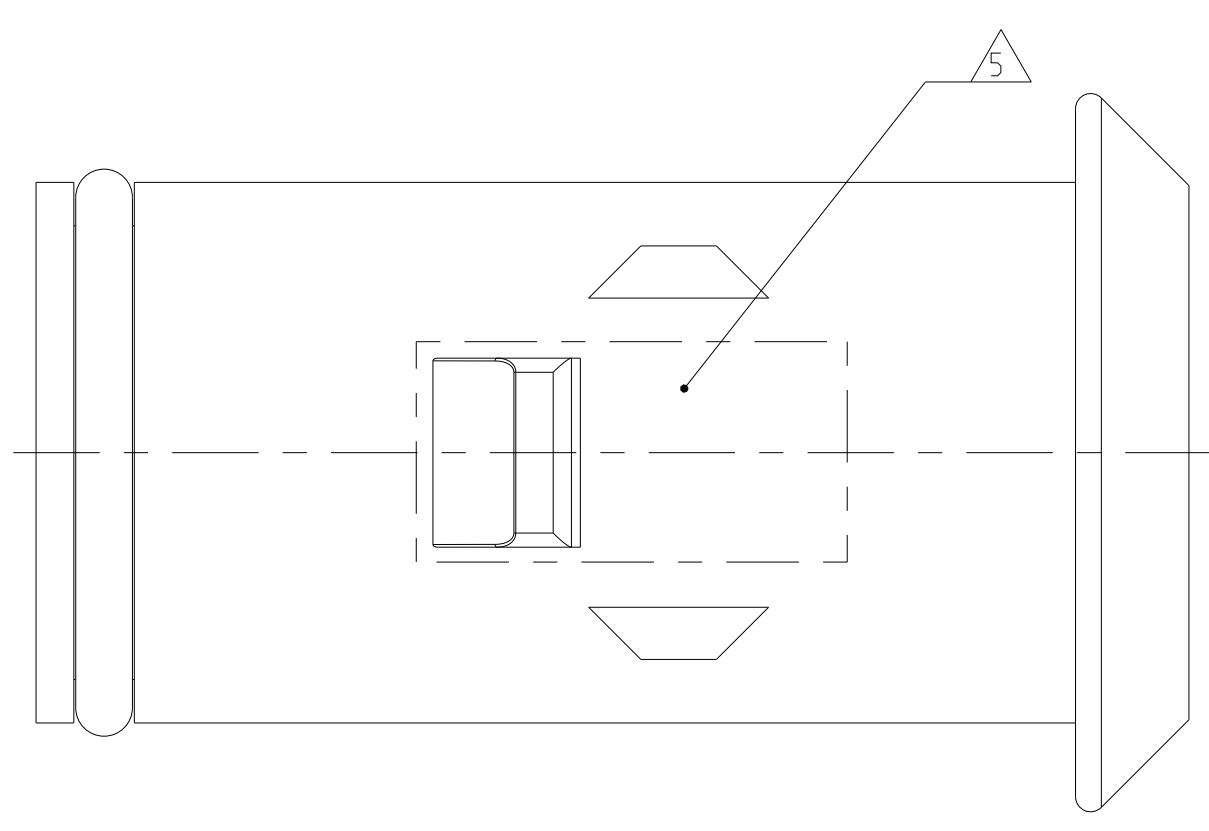
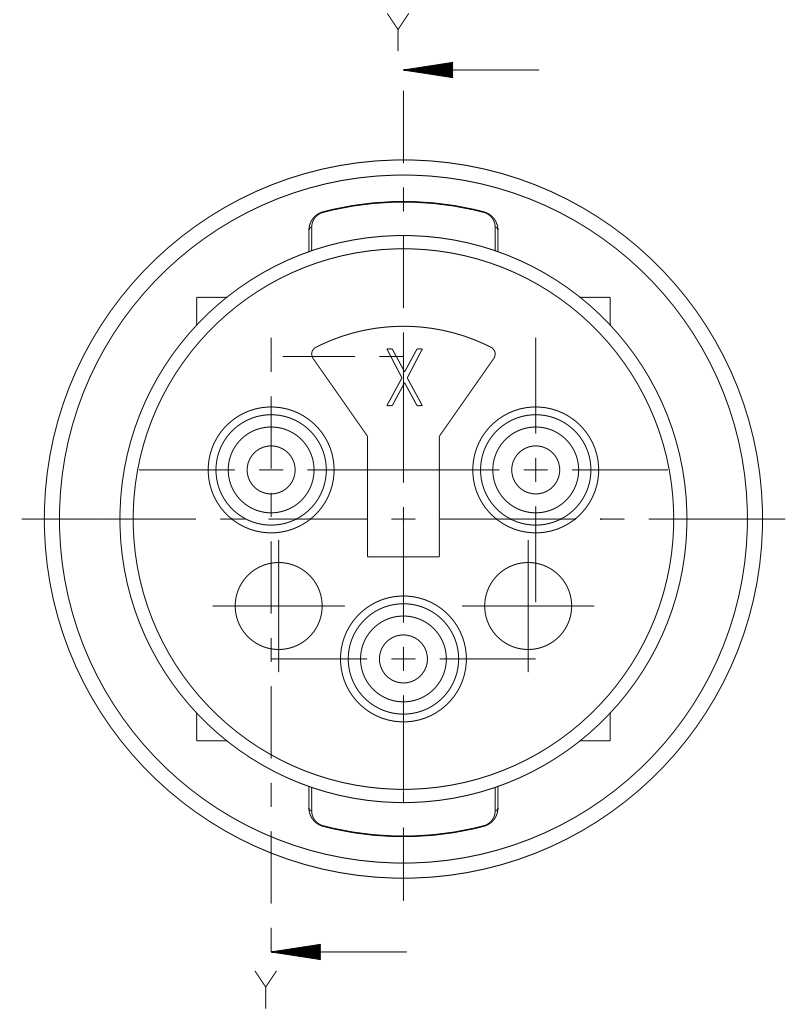
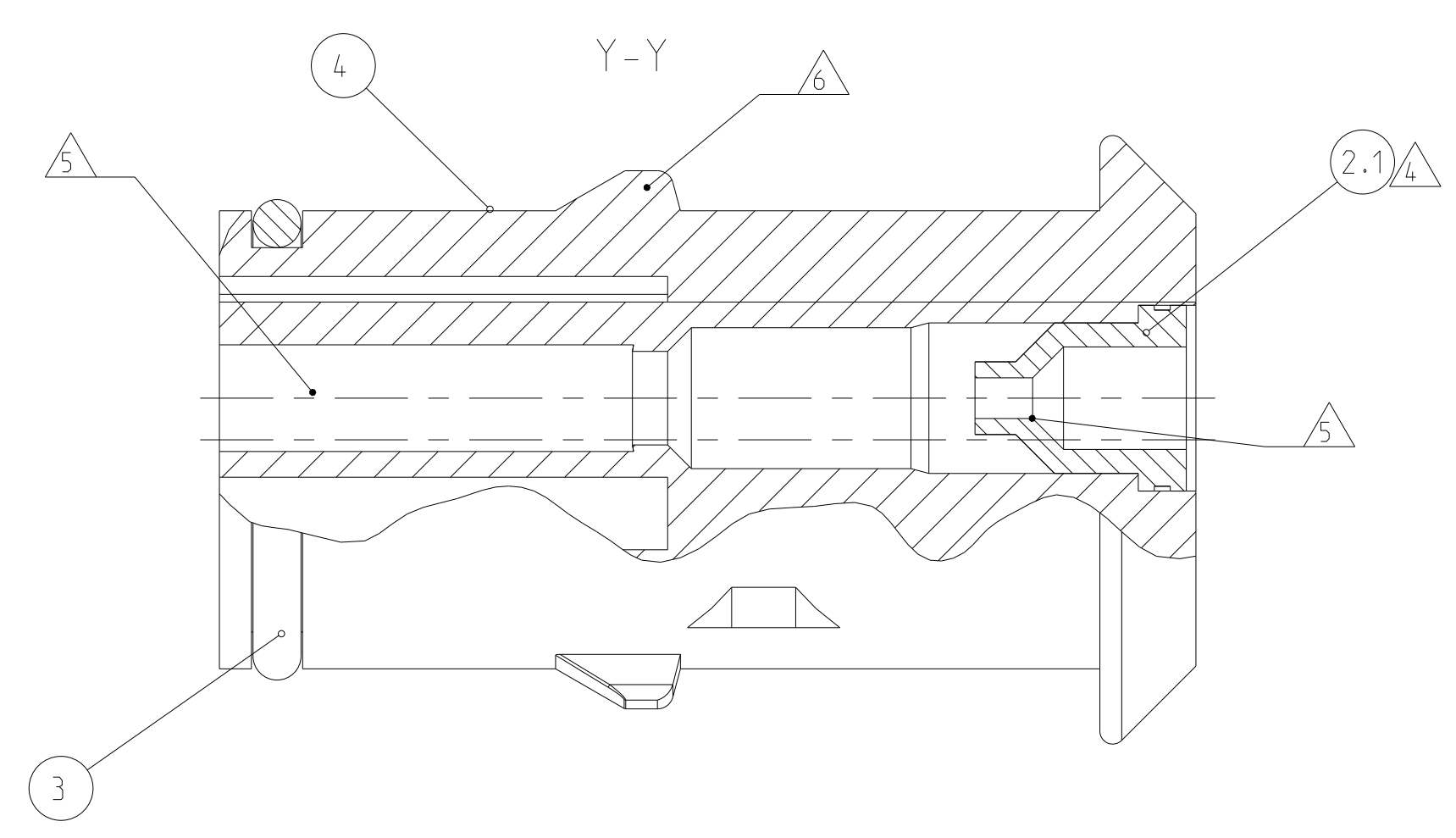

ACHTUNG !
Eine einwandfreie Funktion dieser Stecker kann nur bei Verwendung von Original-TEC-Teilen und genauer Einhaltung der Verarbeitungsanforderungen - schriftlich garantiert werden.
CAUTION !

A faultless operation of this connectors can be guaranteed only if original TEC parts are used and exact observance of processing specifications.

ASSY NO	REV.	DESCRIPTION	MATERIAL	COLOUR	QTY.	ITEM NO
OBSOLETE	2-826886-2	H	SEAL	NEOPRENE	GREY	3 2.1
			O-RING	NEOPRENE	BLACK	1 3
			3 POS. SOCKET HOUSING	PA 6.6 GFV13	GREEN	1 4
OBSOLETE	2-826886-1	H	SEAL	NEOPRENE	BLACK	3 2.2
			O-RING	NEOPRENE	BLACK	1 3
			3 POS. SOCKET HOUSING	PA 6.6 GFV13	NATURAL	1 4
			SEAL	NEOPRENE	GREY	3 2.1
			O-RING	NEOPRENE	BLACK	1 3
			3 POS. SOCKET HOUSING	PA 6.6 GFV13	NATURAL	1 4
			SEAL	NEOPRENE	BLACK	3 2.2
			O-RING	NEOPRENE	BLACK	1 3
			3 POS. SOCKET HOUSING	PA 6.6 GFV13	BLACK	1 4
			SEAL	NEOPRENE	BLACK	3 2.2
			O-RING	NEOPRENE	BLACK	1 3
			3 POS. SOCKET HOUSING	PA 6.6 GFV13	YELLOW	1 4
			SEAL	NEOPRENE	GREY	3 2.1
			O-RING	NEOPRENE	BLACK	1 3
			3 POS. SOCKET HOUSING	PA 6.6 GFV13	RED	1 4
			SEAL	NEOPRENE	GREY	3 2.1
			O-RING	NEOPRENE	BLACK	1 3
			3 POS. SOCKET HOUSING	PA 6.6 GFV13	BLACK	1 4
			O-RING	NEOPRENE	BLACK	1 3
			3 POS. SOCKET HOUSING	PA 6.6 GFV13	BLACK	1 4
			SEAL	NEOPRENE	BLACK	3 2.2
			O-RING	NEOPRENE	BLACK	1 3
			3 POS. SOCKET HOUSING	PA 6.6 GFV13	BLACK	1 1
			SEAL	NEOPRENE	GREY	3 2.1
			O-RING	NEOPRENE	BLACK	1 3
			3 POS. SOCKET HOUSING	PA 6.6 GFV13	RED	1 1
			SEAL	NEOPRENE	GREY	3 2.1
			O-RING	NEOPRENE	BLACK	1 3
			3 POS. SOCKET HOUSING	PA 6.6 GFV13	BLACK	1 1
OBSOLETE	826886-1	H	O-RING	NEOPRENE	BLACK	1 3
			3 POS. SOCKET HOUSING	PA 6.6 GFV13	BLACK	1 1

THIS DRAWING IS A CONTROLLED DOCUMENT. DWG: ADAMSKI 21OCT1982
 CHK: WENDLING 25OCT1982

TE Connectivity

NAME: 3POS. ECONOSEAL SOCKET-HOUSING ASS'Y

PRODUCT SPEC: -

APPLICATION SPEC: -

SIZE: A1 CAGE CODE: 00779 DRAWING NO: 826886 RESTRICTED TO: -

WEIGHT: -

CUSTOMER DRAWING

SCALE: 5:1 SHEET: 1 OF 1 REV: H5