

Time Delay Relays

TSB SERIES

Dedicated • Delay-on-Break



Wiring Diagram

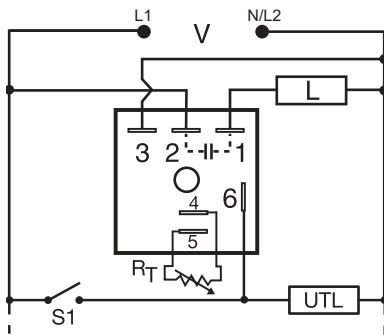

V = Voltage
 S1 = Initiate Switch
 UTL = Optional Untimed Load
 L = Load

R_T is used when external adjustment is ordered.

Description

The TSB Series is a totally solid-state, delay-on-break timing module. The TSB series is available with a fixed, external, or onboard adjustable time delay. Time delays from 0.05 to 600 seconds, in 4 standard ranges, cover over 90 % of all OEM and commercial appliance timing applications. The repeat accuracy is ± 2 %. Operating voltages of 24, 120, or 230 V ac are available. The TSB's 1 A steady state, 10 A rated, solid-state output is perfect for direct control of solenoids, contactors, relays, lamps, buzzers, and small heaters. The TSB series can be surface mounted with a single screw, or snapped on a 35 mm DIN rail using the P1023-20 adapter.

Operation (Delay-on-Break)

Input voltage must be applied before and during timing. Upon closure of the initiate switch, the output energizes. The time delay begins when the initiate switch opens. The output remains energized during timing. At the end of the time delay, the output de-energizes. The output will energize if the initiate switch is closed when input voltage is applied.

Reset: Reclosing the initiate switch during timing resets the time delay. Loss of input voltage resets the output and the time delay.

Features & Benefits

FEATURES	BENEFITS
Analog circuitry	Repeat accuracy ± 2 %, Factory calibration ± 5 %
Totally solid state and encapsulated	No moving parts to arc and wear out over time and encapsulated to protect against shock, vibration, and humidity
Wide time delay range	Meets almost all OEM and commercial appliance timing applications
1A steady, 10A inrush solid state output	Provides 100 million operations in typical conditions

Accessories



P1004-95, P1004-95-X Versa-Pot

Panel mountable, industrial potentiometer recommended for remote time delay adjustment.



P1023-6 Mounting bracket

The 90° orientation of mounting slots makes installation and removal of modules quick and easy.

Ordering Information

MODEL	INPUT VOLTAGE	ADJUSTMENT	TIME DELAY	MODEL	INPUT VOLTAGE	ADJUSTMENT	TIME DELAY
TSB2190	24 V ac	Fixed	90s	TSB422	120 V ac	External	0.5 – 60s
TSB222	24 V ac	External	0.5 – 60s	TSB434	120 V ac	Onboard	5 – 600s
TSB223	24 V ac	External	2 – 180s	TSB632	230 V ac	Onboard	0.5 – 60s
TSB41300	120 V ac	Fixed	300s	TSB634	230 V ac	Onboard	5 – 600s

If you don't find the part you need, call us for a custom product 800-843-8848

Time Delay Relays

TSB SERIES

Accessories



P0700-7 Versa-Knob
Designed for 0.25 in (6.35 mm) shaft of Versa-Pot. Semi-gloss industrial black finish.



P1015-64 (AWG 14/16) Female Quick Connect
These 0.25 in. (6.35 mm) female terminals are constructed with an insulator barrel to provide strain relief.



P1015-18 Quick Connect to Screw Adapter
Screw adapter terminal designed for use with all modules with 0.25 in. (6.35 mm) male quick connect terminals.



C103PM (AL) DIN Rail
35 mm aluminum DIN rail available in a 36 in. (91.4 cm) length.

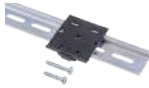

P1023-20 DIN Rail Adapter
Allows module to be mounted on a 35 mm DIN type rail with two #10 screws.

Selection Guide

RT Selection Chart				
Desired Time Delay*				RT
Seconds				
1	2	3	4	Kohms
0.05	0.5	2	5	0
0.3	6	20	60	10
0.6	12	38	120	20
0.9	18	55	180	30
1.2	24	73	240	40
1.5	30	90	300	50
1.8	36	108	360	60
2.1	42	126	420	70
2.4	48	144	480	80
2.7	54	162	540	90
3.0	60	180	600	100

* When selecting an external RT add at least 20% for tolerance of unit and the RT.

Function Diagram

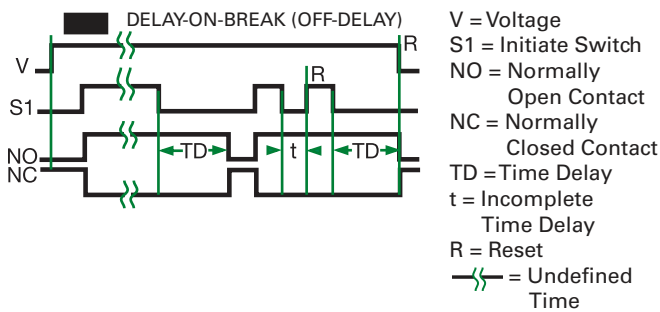

Specifications

Time Delay Range	0.05s–600s in 4 adjustable ranges or fixed
Repeat Accuracy	±2 % or 20 ms, whichever is greater
Tolerance (Factory Calibration)	≤ ±5 %
Time Delay vs Temp. & Voltage	≤ ±10 %
Reset Time	≤ 150 ms
Input Voltage	24, 120, or 230 V ac
Tolerance	±20 %
AC Line Frequency	50/60 Hz
Power Consumption	≤ 2VA
Output Type	Solid state
Form	NO, closed before & during timing
Maximum Load Current	1 A steady state, 10 A inrush at 60 °C
Off State Leakage Current	≅ 5 mA @ 230 V ac
Voltage Drop	≅ 2.5V @ 1 A
Protection Circuitry	Encapsulated
Dielectric Breakdown	≥ 2000V RMS terminals to mounting surface
Insulation Resistance	≥ 100 MΩ
Mechanical Mounting	Surface mount with one #10 (M5 x 0.8) screw
Dimensions	H 50.8 mm (2.0"); W 50.8 mm (2.0"); D 30.7 mm (1.21")
Termination	0.25 in. (6.35 mm) male quick connect terminals
Environmental Operating/Storage Temperature	-40 °C to 75 °C / -40 °C to 85 °C
Humidity	95 % relative, non-condensing
Weight	≅ 2.4 oz (68 g)

Disclaimer Notice – Information furnished is believed to be accurate and reliable. However, users should independently evaluate the suitability of and test each product selected for their own applications. Littelfuse products are not designed for, and may not be used in, all applications. Read complete Disclaimer Notice at www.littelfuse.com/product-disclaimer.