

Product Features

- 3.3V or 5V operating voltage
- Uses an inexpensive external crystal
- Provide clock output enable
- On-chip VCXO with pull range of 240ppm
- VCXO tuning voltage from 0 to Vcc
- 10mA output driver at CMOS levels (3.3V Vcc)
- Available in SOIC package and die form

General Description

The PT7V4027 is a low-cost, high-performance VCXO, designed to replace expensive VCXO modules. The on-chip voltage causes clocks to vary by ± 120 ppm. It uses an inexpensive external pullable crystal at 27MHz to produce the same output frequency.

Ordering Information

Ordering code	Package type	Operating Range
PT7V4027W	8-Pin SOIC	Industrial
PT7V4027WE	8-Pin SOIC lead free	Industrial
PT7V4027DE	Die Form	Industrial

Applications

- Set-Top Box
- xDSL

Logic Block Diagram

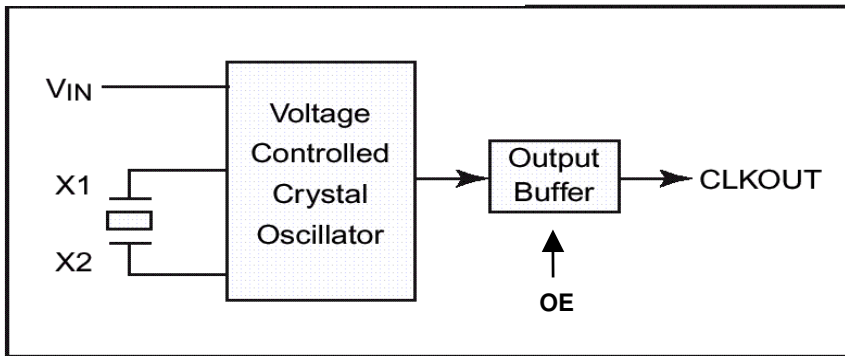

Pin Configuration

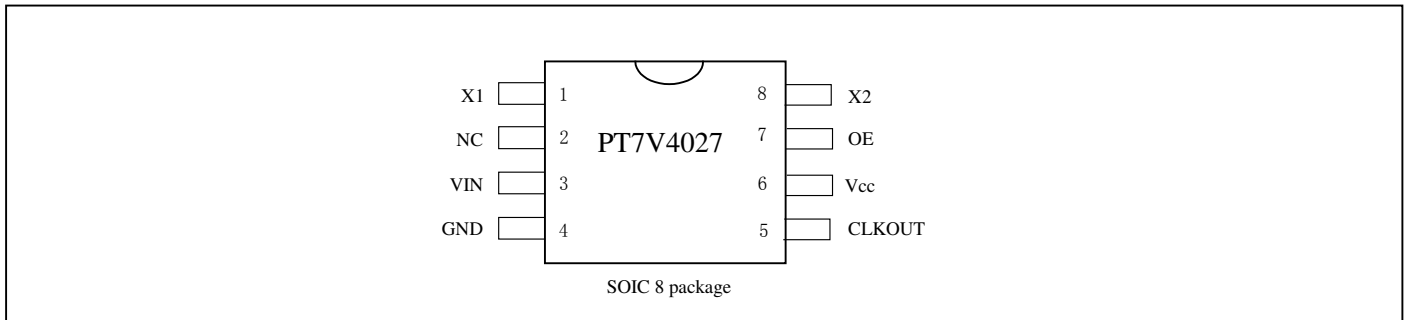

Pin Description

Pin Number	Pin Name	Type	Description
1, 8	X1, X2	I	Crystal Connection, Connect to a pullable 27MHz crystal
2	NC		No Connect, Can be float or connected to V _{CC} or GND
3	V _{IN}	I	Voltage Input to VCXO
4	GND	PWR	Ground
5	CLKOUT	O	Clock Output
6	V _{CC}	PWR	Power Supply +3.3V or 5V
7	OE	I	Output Enable. High or floating enables output. Internal pull-up.

Pad Location

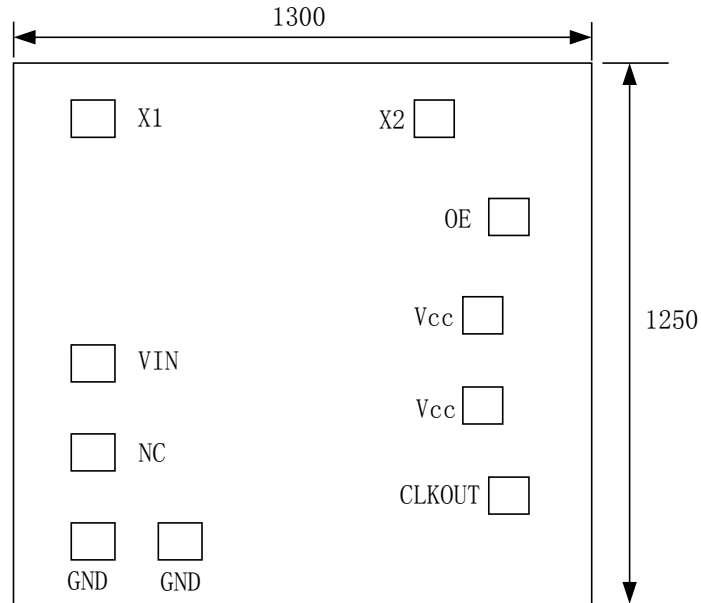

Note: substrate should be tied to GND or floating.

Pad Coordinates					
Pad Name	X Coordinates	Y Coordinates	Pad Name	X Coordinates	Y Coordinates
CLKOUT	553.05	-316.55	X1	-511.55	479.75
Vcc	511.75	-79.35	VIN	-534.3	-124.7
Vcc	511.75	20.75	OE	-534.3	-305.6
OE	554.1	199.75	GND	-534.3	-469.4
X2	312.55	479.75	GND	-375.95	-496.4

Maximum Ratings

(Above which the useful life may be impaired. For user guidelines, not tested.)

Storage Temperature.....	-55°C to 125°C
Ambient Temperature.....	-40°C to 85°C
Supply Voltage V _{CC}	-0.5V to 7V
Input Voltage.....	-0.5V to V _{CC} +0.5V
Output Current	10mA
Soldering Lead Temperature(10s).....	260°C

Note:

Stresses greater than those listed under MAXIMUM RATINGS may cause permanent damage to the device. This is a stress rating only and functional operation of the device at these or any other conditions above those indicated in the operational sections of this specification is not implied. Exposure to absolute maximum rating conditions for extended periods may affect reliability.

DC Electrical Characteristics

(Unless otherwise specified, V_{CC} = 3.3 or 5V, f₀ = 27MHz, V_{IN} = V_{CC}/2, Load = 15pF, T_A = 25°C)

Sym.	Parameter	Test Condition	Pin	Min.	Typ.	Max.	Unit	
V _{CC}	Supply Voltage		V _{CC}	3.153		5.25	V	
I _{CC}	Supply Current	V _{CC} = 3.3V, C _L = 15pF	V _{CC}		5		mA	
		V _{CC} = 5V, C _L = 15pF			8			
I _{DD5}	Supply Current	OE = 0V	V _{CC}			1	mA	
V _{IH}	Input Logic High		OE	2.0			V	
V _{IL}	Input Logic Low		OE			0.8	V	
I _{OH}	High-level output voltage	V _{OH} = V _{CC} - 0.5V	V _{CC} =3.3V	CLKOUT		-11	-4	mA
			V _{CC} =5V	CLKOUT		-18	-8	
I _{OL}	Low-level output voltage	V _{OL} = 0.5V	V _{CC} =3.3V	CLKOUT	4	12		
			V _{CC} =5V	CLKOUT	8	18		
I _{OZ}	Output Leakage Current	OE = 0V	CLKOUT			10	µA	
R _S *	Negative Resistance	V _{IN} = 0V	X1, X2		-150		Ω	
f	Input Frequency	V _{CC} =5.0V	X1, X2	20	27	40	MHz	
		V _{CC} =3.3V	X1, X2	15	27	40		
C _L	Output Capacitance		CLKOUT		15	30	pF	

* Note: only reference for design.

AC Electrical Characteristics

(Unless otherwise specified, V_{CC} = 3.3 or 5V, f₀ = 27MHz, Load = 15pF, T_A = 25°C)

Sym.	Parameter	Test Condition	Pin	Min.	Typ.	Max.	Unit	
t _r / t _f	Rise / Fall time	0.1V _{CC} to 0.9V _{CC}	V _{CC} =3.3V	CLKOUT		1.5	6	ns
			V _{CC} =5V			1.0	3	
Duty	Output clock duty cycle	At V _{CC} /2	CLKOUT	45	50	55	%	
Δf	Output frequency pull range	V _{IN} from 0V to V _{CC}			±120		ppm	
t _j	Cycle to cycle jitter				50		ps	
	Linearity	V _{IN} from 0.1 to 0.9V _{CC}			±10		%	
	Oscillator start time	Trigger at 0.9V _{CC}			1.5	10	ms	

Recommended Crystal Specifications

Description	Crystal
Mode of Oscillation	Fundamental
Frequency Range	27.000MHz
Frequency Tolerance	±30ppm
Temperature plus Aging Stability	±50ppm
Operating Temperature	-20°C to + 70°C
C0/C1	240(max.)
Load Capacitance(C _L)	18pF
Equivalent Series Resistance(ESR)	35ohms(max.)

Plastic 8-pin SOIC (W) Package

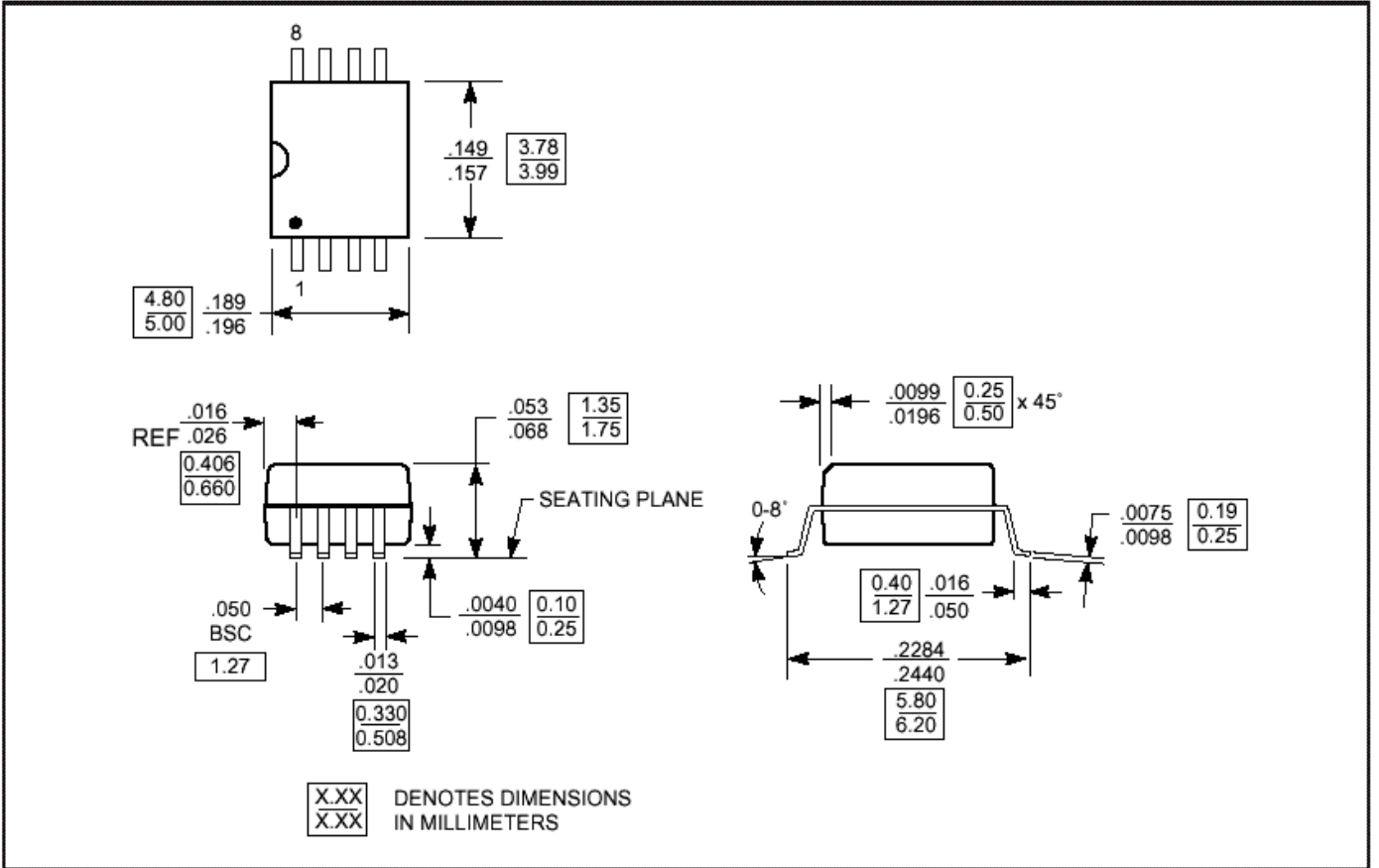

Notes

Pericom Technology Inc.

Email: support@pti.com.cn Web Site: www.pti.com.cn, www.pti-ic.com

China: No. 20 Building, 3/F, 481 Guiping Road, Shanghai, 200233, China
Tel: (86)-21-6485 0576 Fax: (86)-21-6485 2181

Asia Pacific: Unit 1517, 15/F, Chevalier Commercial Centre, 8 Wang Hoi Rd, Kowloon Bay, Hongkong
Tel: (852)-2243 3660 Fax: (852)- 2243 3667

U.S.A.: 3545 North First Street, San Jose, California 95134, USA
Tel: (1)-408-435 0800 Fax: (1)-408-435 1100

Pericom Technology Incorporation reserves the right to make changes to its products or specifications at any time, without notice, in order to improve design or performance and to supply the best possible product. Pericom Technology does not assume any responsibility for use of any circuitry described other than the circuitry embodied in Pericom Technology product. The company makes no representations that circuitry described herein is free from patent infringement or other rights, of Pericom Technology Incorporation.