

Data Sheet

HAL[®] 83x

Robust Multi-Purpose Programmable
Linear Hall-Effect Sensor Family

Copyright, Warranty, and Limitation of Liability

The information and data contained in this document are believed to be accurate and reliable. The software and proprietary information contained therein may be protected by copyright, patent, trademark and/or other intellectual property rights of TDK-Micronas. All rights not expressly granted remain reserved by TDK-Micronas.

TDK-Micronas assumes no liability for errors and gives no warranty representation or guarantee regarding the suitability of its products for any particular purpose due to these specifications.

By this publication, TDK-Micronas does not assume responsibility for patent infringements or other rights of third parties which may result from its use. Commercial conditions, product availability and delivery are exclusively subject to the respective order confirmation.

Any information and data which may be provided in the document can and do vary in different applications, and actual performance may vary over time.

All operating parameters must be validated for each customer application by customers' technical experts. Any new issue of this document invalidates previous issues. TDK-Micronas reserves the right to review this document and to make changes to the document's content at any time without obligation to notify any person or entity of such revision or changes. For further advice please contact us directly.

Do not use our products in life-supporting systems, military, aviation, or aerospace applications! Unless explicitly agreed to otherwise in writing between the parties, TDK-Micronas' products are not designed, intended or authorized for use as components in systems intended for surgical implants into the body, or other applications intended to support or sustain life, or for any other application in which the failure of the product could create a situation where personal injury or death could occur.

No part of this publication may be reproduced, photocopied, stored on a retrieval system or transmitted without the express written consent of TDK-Micronas.

TDK-Micronas Trademarks

– HAL

TDK-Micronas Patents

EP0 953 848, EP 1 039 357, EP 1 575 013

Third-Party Trademarks

All other brand and product names or company names may be trademarks of their respective companies.

Contents

Page	Section	Title
5	1.	Introduction
6	1.1.	Applications
6	1.2.	General Features
6	1.2.1.	Device-specific features of HAL835
7	2.	Ordering Information
7	2.1.	Device-Specific Ordering Codes
8	3.	Functional Description
8	3.1.	General Function
11	3.2.	A/D Converter
12	3.3.	Digital Signal Processing and EEPROM
20	3.4.	Calibration Procedure
20	3.4.1.	General Procedure
23	4.	Specifications
23	4.1.	Outline Dimensions
27	4.2.	Soldering, Welding and Assembly
27	4.3.	Pin Connections and Short Descriptions
27	4.4.	Dimensions of Sensitive Area
28	4.5.	Absolute Maximum Ratings
29	4.6.	Storage and Shelf Life
29	4.7.	Recommended Operating Conditions
30	4.8.	Characteristics
32	4.8.1.	Additional Information
33	4.8.2.	PWM Output (HAL835 only)
33	4.8.3.	TO92UT Packages
33	4.8.4.	Definition of sensitivity error ES
35	4.8.5.	Power-On Operation
36	4.9.	Diagnostics and Safety Features
36	4.9.1.	Overvoltage and Undervoltage Detection
36	4.9.2.	Open-Circuit Detection
37	4.9.3.	Overtemperature and Short-Circuit Protection
37	4.9.4.	EEPROM Redundancy
37	4.9.5.	ADC Diagnostic
38	5.	Application Notes
38	5.1.	Application Circuit (for analog output mode only)
39	5.2.	Use of two HAL83x in Parallel (for analog output mode only)
40	5.3.	Temperature Compensation
42	5.4.	Ambient Temperature
42	5.5.	EMC and ESD

Contents

Page	Section	Title
43	6.	Programming
43	6.1.	Definition of Programming Pulses
43	6.2.	Definition of the Telegram
46	6.3.	Telegram Codes
47	6.4.	Number Formats
48	6.5.	Register Information
51	6.6.	Programming Information
53	7.	Data Sheet History

Robust Multi-Purpose Programmable Linear Hall-Effect Sensor Family

Release Note: Revision bars indicate significant changes to the previous edition.

1. Introduction

The HAL83x is a family of programmable linear Hall sensors from TDK-Micronas. This robust multipurpose sensors can replace the HAL 805, HAL 815, HAL 825, and HAL810. HAL 83x offers better quality, extended functionality and performance compared to the first generation devices. This family consists of two members: the HAL830 and the HAL835. HAL835 is the device with the full feature set and maximum performance compared with the HAL830.

The HAL83x is an universal magnetic field sensor with linear output based on the Hall effect. The IC can be used for angle or distance measurements when combined with a rotating or moving magnet. The major characteristics like magnetic field range, sensitivity, output quiescent voltage (output voltage at $B = 0$ mT), and output voltage range are programmable in a non-volatile memory. The sensor has a ratiometric output characteristic, which means that the output voltage is proportional to the magnetic flux and the supply voltage. It is possible to program several devices connected to the same supply and ground line.

The HAL83x features a temperature-compensated Hall plate with spinning-current offset compensation, an A/D converter, digital signal processing, a D/A converter with output driver, an EEPROM memory with redundancy and lock function for the calibration data, an EEPROM for customer serial number, a serial interface for programming the EEPROM, and protection devices at all pins.

The HAL83x is programmable by modulating the supply voltage. No additional programming pin is needed. The easy programmability allows a 2-point calibration by adjusting the output voltage directly to the input signal (like mechanical angle, distance, or current). Individual adjustment of each sensor during the customer's manufacturing process is possible. With this calibration procedure, the tolerances of the sensor, the magnet, and the mechanical positioning can be compensated in the final assembly.

In addition, the temperature compensation of the Hall IC can be fit to common magnetic materials by programming first and second order temperature coefficients of the Hall sensor sensitivity. This enables operation over the full temperature range with high accuracy.

The calculation of the individual sensor characteristics and the programming of the EEPROM memory can easily be done with a PC and the application kit from TDK-Micronas.

The sensor is designed for hostile industrial and automotive applications and operates with typically 5 V supply voltage in the ambient temperature range from -40 °C up to 160 °C. The HAL83x is available in the very small leaded package TO92UT-1/-2 and is AECQ 100 qualified.

1.1. Applications

Due to the sensor's versatile programming characteristics and low temperature drift, the HAL 83x is the optimal system solution for applications such as:

- Pedal, turbo-charger, throttle and EGR systems
- Distance measurements

1.2. General Features

- high-precision linear Hall-effect sensor family with 12 bit ratiometric analog output and digital signal processing
- multiple programmable magnetic characteristics in a non-volatile memory (EEPROM) with redundancy and lock function
- operates from $T_J = -40\text{ °C}$ up to 170 °C
- operates from 4.5 V up to 5.5 V supply voltage in specification and functions up to 8.5 V
- operates with static magnetic fields and dynamic magnetic fields up to 2 kHz
- programmable magnetic field range from $\pm 30\text{ mT}$ up to $\pm 150\text{ mT}$
- open-circuit (ground and supply line break detection) with $5\text{ k}\Omega$ pull-up and pull-down resistor, overvoltage and undervoltage detection
- for programming an individual sensor within several sensors in parallel to the same supply voltage, a selection can be done via the output pin
- temperature characteristics are programmable for matching common magnetic materials
- programmable clamping function
- programming via modulation of the supply voltage
- overvoltage and reverse-voltage protection at all pins
- magnetic characteristics extremely robust against mechanical stress
- short-circuit protected push-pull output
- EMC and ESD optimized design

1.2.1. Device-specific features of HAL835

- very low offset ($\pm 0.2\% V_{SUP}$) and sensitivity ($\pm 1\%$) drift over temperature
- selectable PWM output with 11 bit resolution and 8 ms period
- 14 bit multiplex analog output
- $\pm 15\text{ mT}$ magnetic range

2. Ordering Information

A Micronas device is available in a variety of delivery forms. They are distinguished by a specific ordering code:

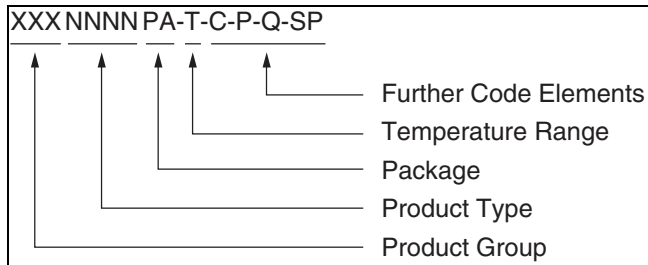

Fig. 2–1: Ordering Code Principle

For a detailed information, please refer to the brochure: “Micronas Sensors and Controllers: Ordering Codes, Packaging, Handling”.

2.1. Device-Specific Ordering Codes

The HAL 83x is available in the following package and temperature variants.

Table 2–1: Available packages

Package Code (PA)	Package Type
UT	TO92UT-1/2

Table 2–2: Available temperature ranges

Temperature Code (T)	Temperature Range
A	$T_J = -40\text{ °C to }170\text{ °C}$

The relationship between ambient temperature (T_A) and junction temperature (T_J) is explained in Section 5.4. on page 42.

For available variants for Configuration (C), Packaging (P), Quantity (Q), and Special Procedure (SP) please contact TDK-Micronas.

Table 2–3: Available ordering codes and corresponding package marking

Available Ordering Codes	Package Marking
HAL830UT-A-[C-P-Q-SP]	830A
HAL835UT-A-[C-P-Q-SP]	835A

3. Functional Description

3.1. General Function

The HAL83x is a programmable linear Hall-Effect sensor which provides an output signal proportional to the magnetic flux through the Hall plate and proportional to the supply voltage (ratiometric behavior) as long as the analog output mode is selected. When the PWM output mode is selected, the PWM signal is not ratiometric to the supply voltage (for HAL 835 only).

The external magnetic field component perpendicular to the branded side of the package generates a Hall voltage. The Hall IC is sensitive to magnetic north and south polarity. This voltage is converted to a digital value, processed in the Digital Signal Processing Unit (DSP) according to the settings of the EEPROM registers and converted to an output signal. The function and the parameters for the DSP are explained in Section 3.2. on page 11.

The setting of the LOCK register disables the programming of the EEPROM memory for all time. It also disables the reading of the memory. This register cannot be reset.

As long as the LOCK register is not set, the output characteristic can be adjusted by programming the EEPROM registers. The IC is addressed by modulating the supply voltage (see Fig. 3–1). In the supply voltage range from 4.5 V up to 5.5 V, the sensor generates an normal output signal. After detecting a command, the sensor reads or writes the memory and answers with a digital signal on the output pin (see also application note “HAL 8xy, HAL 100x Programmer Board”). The output switches from analog to digital during the communication. Several sensors in parallel to the same supply and ground line can be programmed individually. The selection of each sensor is done via its output pin.

For HAL835 the digital output for generation of the BiPhase-M programming protocol is also used to generate the PWM output signal.

The open-circuit detection function provides a defined output voltage for the analog output if the V_{SUP} or GND line are broken. Internal temperature compensation circuitry and spinning-current offset compensation enable operation over the full temperature range with minimal changes in accuracy and high offset stability. The circuitry also reduces offset shifts due to mechanical stress from the package. The non-volatile memory consists of redundant and non-redundant EEPROM cells. The non-redundant EEPROM cells are only used to store production information for tracking inside the sensor. In addition, the sensor IC is equipped with devices for overvoltage and reverse-voltage protection at all pins.

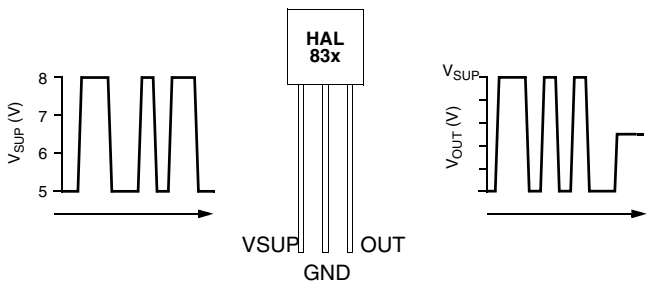

Fig. 3–1: Programming with V_{SUP} modulation

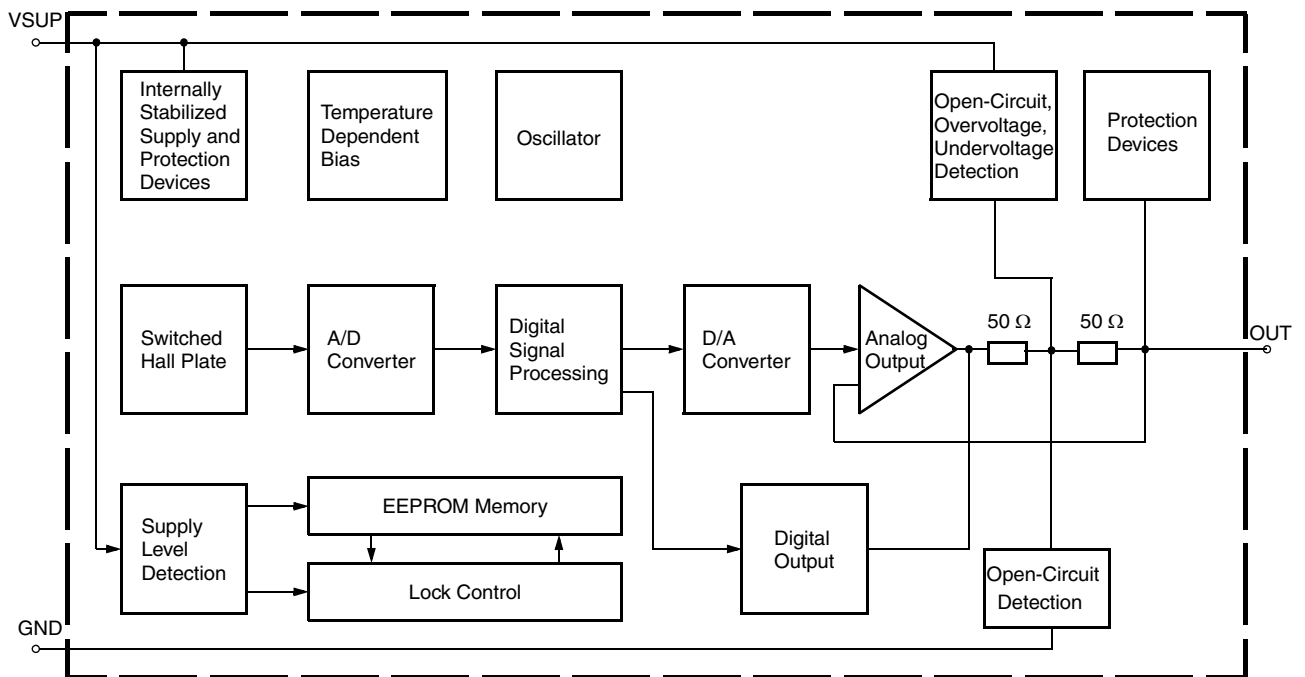

Fig. 3–2: HAL83x block diagram

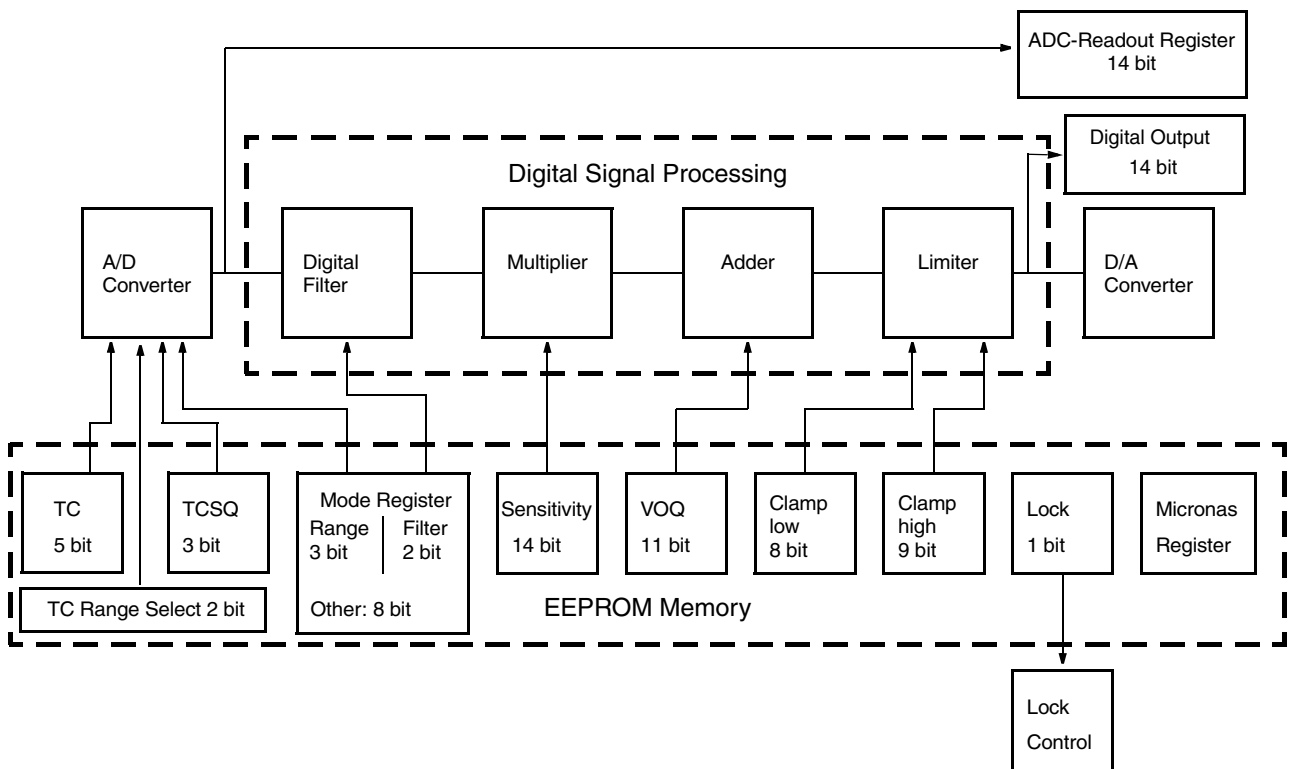

Fig. 3–3: Details of EEPROM Registers and Digital Signal Processing

3.2. A/D Converter

The ADC used in HAL83x sensor has a "Sigma-Delta" architecture. It delivers an over-sampled multi-bit stream with high-frequency shaped quantization noise. Low-pass filtering performs an averaging of the signal by accumulation. With longer accumulation the resolution of the data converter increases.

The accumulation takes place in the decimating filter, the low-pass filter, and the external RC-filter.

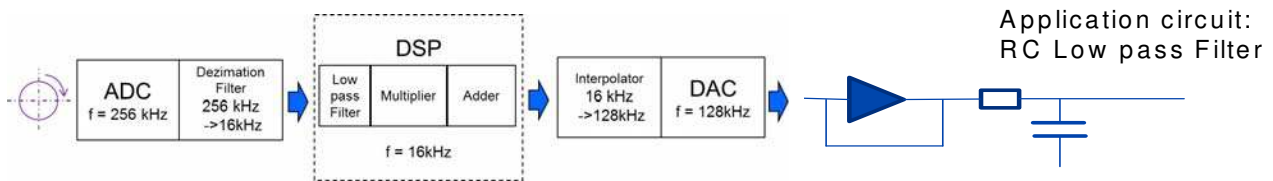

Fig. 3-4: Signal path

Example of a Sigma-Delta-ADC (simplified illustration)

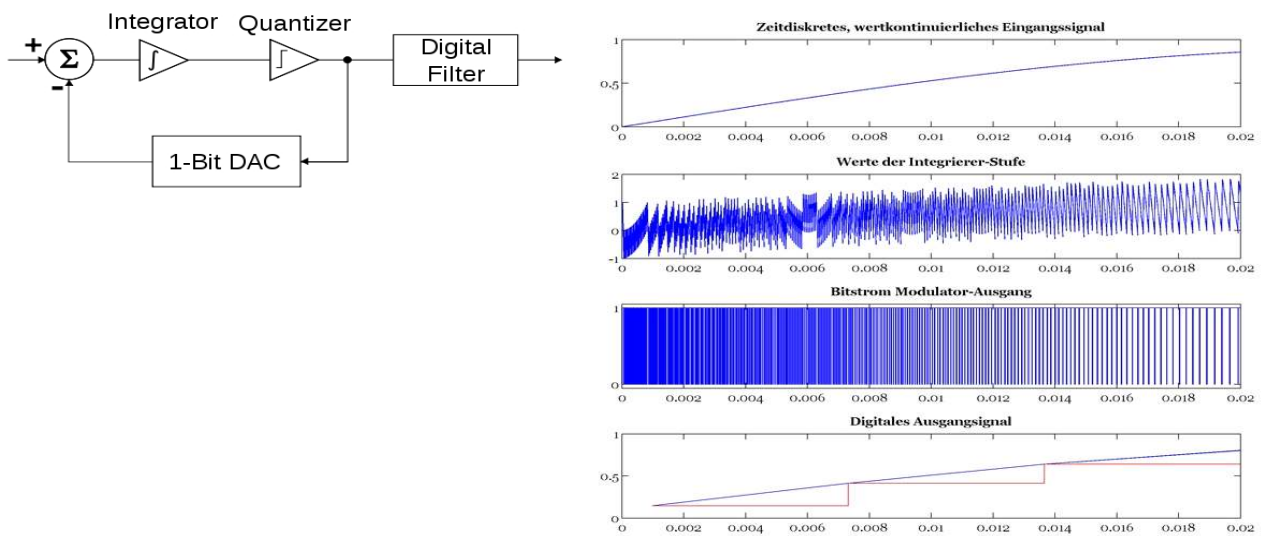

Fig. 3-5: Sigma-Delta-ADC

- A: Input Signal
- B: Integrated value
- C: High frequency data stream (modulated)

After filtering (D), the signal is reconstructed: the lower the cutoff frequency of this filter the higher is the resolution.

The A/D readout of the sensor is a snapshot of the explained data stream.

3.3. Digital Signal Processing and EEPROM

The DSP performs signal conditioning and allows adaption of the sensor to the customer application. The parameters for the DSP are stored in the EEPROM registers. The details are shown in Fig. 3–3.

Terminology:

SENSITIVITY: name of the register or register value

Sensitivity: name of the parameter

The EEPROM registers consist of four groups:

Group 1 contains the registers for the adaptation of the sensor to the magnetic system: MODE for selecting the magnetic field range and filter frequency, TC, TCSQ and TC-Range for the temperature characteristics of the magnetic sensitivity.

Group 2 contains the registers for defining the output characteristics: SENSITIVITY, VOQ, CLAMP-LOW (MIN-OUT), CLAMP-HIGH (MAX-OUT) and OUTPUT MODE. The output characteristic of the sensor is defined by these parameters.

- The parameter V_{OQ} (Output Quiescent Voltage) corresponds to the output signal at $B = 0$ mT.
- The parameter Sensitivity defines the magnetic sensitivity:

$$\text{Sensitivity} = \frac{\Delta V_{OUT}}{\Delta B}$$

- The output voltage can be calculated as:

$$V_{OUT} = \text{Sensitivity} \times B + V_{OQ}$$

The output voltage range can be clamped by setting the registers CLAMP-LOW and CLAMP-HIGH in order to enable failure detection (such as short-circuits to V_{SUP} or GND and open connections).

Group 3 contains the general purpose register GP. The GP Register can be used to store customer information, like a serial number after manufacturing. TDK-Micronas will use this GP REGISTER to store informations like, Lot number, wafer number, x and y position of the die on the wafer, etc. This information can be read by the customer and stored in its own data base or it can stay in the sensor as is.

Group 4 contains the Micronas registers and LOCK for the locking of all registers. The MICRONAS registers are programmed and locked during production. These registers are used for oscillator frequency trimming, A/D converter offset compensation, and several other special settings.

An external magnetic field generates a Hall voltage on the Hall plate. The ADC converts the amplified positive or negative Hall voltage (operates with magnetic north and south poles at the branded side of the package) to a digital value. This value can be read by the A/D-READOUT register to ensure that the suitable converter modulation is achieved. The digital signal is filtered in the internal low-pass filter and manipulated according to the settings stored in the EEPROM. The digital value after signal processing is readable in the D/A-READOUT register. Depending on the programmable magnetic range of the Hall IC, the operating range of the A/D converter is from $-15\text{ mT} \dots +15\text{ mT}$ up to $-150\text{ mT} \dots +150\text{ mT}$.

During further processing, the digital signal is multiplied with the sensitivity factor, added to the quiescent output voltage level and limited according to the clamping voltage levels. The result is converted to an analog signal and stabilized by a push-pull output stage.

The D/A-READOUT at any given magnetic field depends on the programmed magnetic field range, the low-pass filter, SENSITIVITY, VOQ, TC values and CLAMP-LOW and CLAMP-HIGH. The D/A-READOUT range is min. 0 and max. 16383.

Note During application design, it should be taken into consideration that the maximum and minimum D/A-READOUT should not violate the error band of the operational range.

MODE register

The MODE register contains all bits used to configure the A/D converter and the different output modes.

Table 3–1: MODE register of HAL830 / HAL835

MODE										
Bit Number	9	8	7	6	5	4	3	2	1	0
Parameter	RANGE	Reserved	OUTPUT-MODE			FILTER		RANGE (together with bit 9)		Reserved

Magnetic Range

The RANGE bits define the magnetic field range of the A/D converter.

Table 3–2: Magnetic Range HAL 835

Magnetic Range	RANGE	
MODE	MODE [9]	MODE [2:1]
±15 mT	1	00
±30 mT	0	00
±60 mT	0	01
±80 mT	0	10
±100 mT	0	11
±150 mT	1	11

Table 3–3: Magnetic Range HAL 830

Magnetic Range	RANGE	
	MODE [9]	MODE [2:1]
±30 mT	0	00
±60 mT	0	01
±80 mT	0	10
±100 mT	0	11
±150 mT	1	11

Filter

The FILTER bits define the –3 dB frequency of the digital low-pass filter.

Table 3–4: FILTER bits defining the –3 dB frequency

–3 dB Frequency	MODE [4:3]
80 Hz	00
500 Hz	10
1 kHz	11
2 kHz	01

Output Format

The OUTPUTMODE bits define the different output modes of HAL83x.

Table 3–5: OUTPUTMODE for HAL835

Output Format	MODE [7:5]
Analog Output (12 bit)	000
Multiplex Analog Output (continuously)	001
Multiplex Analog Output (external trigger)	011
Burn-In Mode	010
PWM	110
PWM (inverted polarity)	111

Table 3–6: OUTPUTMODE for HAL830

Output Format	MODE [7:5]
Analog Output (12 bit)	000

In **Analog Output** mode the sensor provides an ratiometric 12 bit analog output voltage between 0 V and 5 V.

In **Multiplex Analog Output** mode the sensor delivers two analog 7-bit values. The 7 LSB (least significant bits) and the 7 MSB of the output value are transmitted separately. This enables the sensor to transmit a 14-bit signal to the 8-bit A/D converter of an ECU with the advantage of achieving a higher signal-to-noise ratio in a disturbed environment.

- In external trigger mode the ECU can switch the output of the sensor between LSB and MSB by changing the current flow direction through the sensor's output. In case the output is pulled up by a 10 k Ω resistor, the sensor sends the MSB. If the output is pulled down, the sensor will send the LSB. Maximum refresh rate is about 500 Hz (2 ms).
- In continuous mode the sensor transmits first LSB and then MSB continuously and the ECU must listen to the data stream sent by the sensor.

In the Multiplex Analog Output mode 1 LSB is represented by a voltage level change of 39 mV. In Analog Output mode with 14 bit 1 LSB would be 0.31 mV.

In **Burn-In Mode** the signal path of the sensors DSP is stimulated internally without applied magnetic field. In this mode the sensor provides a “saw tooth” shape output signal. Shape and frequency of the saw tooth signal depend on the programming of the sensor. This mode can be used for Burn-In test in the customers production line.

In **PWM** mode the sensor provides an 11 bit PWM output. The PWM period is 8 ms and the output signal will change between 0 V and 5 V supply voltage. The magnetic field information is coded in the duty cycle of the PWM signal. The duty cycle is defined as the ratio between the high time “s” and the period “d” of the PWM signal (see Fig. 3–6).

Note The PWM signal is updated with the rising edge. If the duty cycle is evaluated with a microcontroller, the trigger-level for the measurement value should be the falling edge. Please use the rising edge to measure the PWM period.

For PWM (inverted) the duty-cycle value is then inverted. Meaning that a 70% duty-cycle in normal PWM mode is 30% duty-cycle in PWM (inverted) mode.

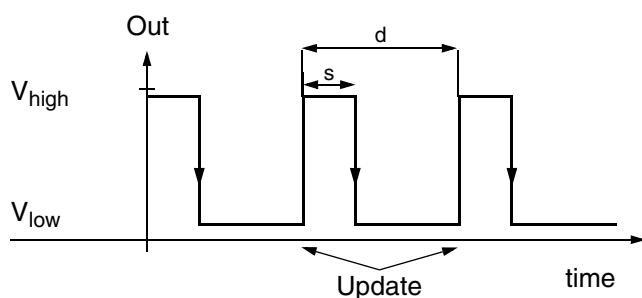

Fig. 3–6: Definition of PWM signal

TC Register

The temperature dependence of the magnetic sensitivity can be adapted to different magnetic materials in order to compensate for the change of the magnetic strength with temperature. The adaptation is done by programming the TC (Temperature Coefficient) and the TCSQ registers (Quadratic Temperature Coefficient). Thereby, the slope and the curvature of the temperature dependence of the magnetic sensitivity can be matched to the magnet and the sensor assembly. As a result, the output voltage characteristic can be constant over the full temperature range. The sensor can compensate for linear temperature coefficients ranging from about -3100 ppm/K up to 1000 ppm/K and quadratic coefficients from about -7 ppm/K² to 2 ppm/K².

The full TC range is separated in the following four TC range groups (see Table 3–7 and Table 5–1 on page 40).

Table 3–7: TC-Range Groups

TC-Range [ppm/k]	TC-Range Group (see also Table 5–1 on page 40)
-3100 to -1800 (not for ± 15 mT range)	0
-1750 to -550 (not for ± 15 mT range)	2
-500 to $+450$ (default value)	1
$+450$ to $+1000$	3

TC (5 bit) and TCSQ (3 bit) have to be selected individually within each of the four ranges. For example 0 ppm/k requires TC-Range = 1, TC = 15 and TCSQ = 1. Please refer to Section 5.3. for more details.

Sensitivity

The SENSITIVITY register contains the parameter for the multiplier in the DSP. The Sensitivity is programmable between -4 and 4 . For $V_{SUP} = 5$ V, the register can be changed in steps of 0.00049 .

For all calculations, the digital value from the magnetic field of the D/A converter is used. This digital information is readable from the D/A-READOUT register.

$$\text{SENSITIVITY} = \frac{\Delta V_{\text{OUT}} \times 16383}{(\Delta \text{D/A-READOUT} \times V_{\text{DD}})} \times \text{Sens}_{\text{INITIAL}}$$

VOQ

The VOQ register contains the parameter for the adder in the DSP. V_{OQ} is the output signal without external magnetic field ($B = 0$ mT) and programmable from $-V_{SUP}$ (-100% duty-cycle) up to V_{SUP} (100% duty-cycle). For $V_{SUP} = 5$ V, the register can be changed in steps of 4.9 mV (0.05% duty-cycle).

Note: If V_{OQ} is programmed to a negative value, the maximum output signal is limited to:

$$V_{OUTmax} = V_{OQ} + V_{SUP}$$

Clamping Levels

The output signal range can be clamped in order to detect failures like shorts to V_{SUP} or GND or an open circuit.

The CLAMP-LOW register contains the parameter for the lower limit. The lower clamping limit is programmable between 0 V (min. duty-cycle) and $V_{SUP}/2$ (50% duty-cycle). For $V_{SUP} = 5$ V, the register can be changed in steps of 9.77 mV (0.195% duty-cycle).

The CLAMP-HIGH register contains the parameter for the upper limit. The upper clamping voltage is programmable between 0 V (min. duty-cycle) and V_{SUP} (max. duty-cycle). For $V_{SUP} = 5$ V, in steps of 9.77 mV (0.195% duty-cycle).

GP Register

The register GP0 to GP 3 can be used to store some information, like production date or customer serial number. TDK-Micronas will store production Lot number, wafer number and x,y coordinates in registers GP1 to GP3. The total register contains of four blocks with a length of 13 bit each. The customer can read out this information and store it in his production data base for reference or he can store own production information instead.

Note This register has no redundancy (and guarantee is limited) for traceability.

To read/write this register it is mandatory to read/write all GP register one after the other starting with GP0. In case of writing the registers it is necessary to first write all registers followed by one store sequence at the end. Even if only GP0 should be changed all other GP registers must first be read and the read out data must be written again to these registers.

LOCK

By setting the 1-bit register all registers will be locked and the sensor will no longer respond to any supply voltage modulation. This bit is active after the first power-off and power-on sequence after setting the LOCK bit. EMC properties of the HAL83x is only guaranteed for locked devices.

Warning This register cannot be reset!

D/A-READOUT

This 14-bit register delivers the actual digital value of the applied magnetic field after the signal processing. This register can be read out and is the basis for the calibration procedure of the sensor in the system environment.

Note The MSB and LSB are reversed compared with all the other registers. Please reverse this register after readout.

Note **HAL835:** During calibration it is mandatory to select the Analog Output as output format. The D/A-Readout register can be read out only in the Analog Output mode. For all other modes the result read back from the sensor will be a 0. After the calibration the output format can than easily be switched to the wanted output mode, like PWM.

3.4. Calibration Procedure

3.4.1. General Procedure

For calibration in the system environment, the application kit from TDK-Micronas is recommended. It contains the hardware for generation of the serial telegram for programming (Programmer Board Version 5.1) and the corresponding software (PC83x) for the input of the register values.

For the individual calibration of each sensor in the customer application, a two point adjustment is recommended. The calibration shall be done as follows:

Step 1: Input of the registers which need not be adjusted individually

The magnetic circuit, the magnetic material with its temperature characteristics, the filter frequency, the output mode and the GP register value are given for this application. Therefore, the values of the following register blocks should be identical for all sensors of the customer application.

- FILTER
(according to the maximum signal frequency)
- RANGE
(according to the maximum magnetic field at the sensor position)
- OUTPUTMODE
- TC, TCSQ and TC-RANGE
(depends on the material of the magnet and the other temperature dependencies of the application)
- GP
(if the customer wants to store own production information. It is not necessary to change this register)

As the clamping levels are given. They have an influence on the D/A-Readout value and have to be set therefore after the adjustment process.

Write the appropriate settings into the HAL83x registers.

Step 2: Initialize DSP

As the D/A-READOUT register value depends on the settings of SENSITIVITY, VOQ and CLAMP-LOW/HIGH, these registers have to be initialized with defined values, first:

- $VOQ_{INITIAL} = 2.5 \text{ V}$
- Clamp-Low = 0 V
- Clamp-High = 4.999 V
- $Sens_{INITIAL}$ (see Table 3–8)

Table 3–8: $Sens_{INITIAL}$

3dB Filter frequency	$Sens_{INITIAL}$
80 Hz	0.464
500 Hz	0.3
1 kHz	0.321
2 kHz	0.641

Step 3: Define Calibration Points

The calibration points 1 and 2 can be set inside the specified range. The corresponding values for V_{OUT1} and V_{OUT2} result from the application requirements.

$$\text{LowClampingVoltage} \leq V_{OUT1,2} \leq \text{HighClampingVoltage}$$

For highest accuracy of the sensor, calibration points near the minimum and maximum input signal are recommended. The difference of the output voltage between calibration point 1 and calibration point 2 should be more than 3.5 V.

Step 4: Calculation of V_{OQ} and Sensitivity

Set the system to calibration point 1 and read the register D/A-READOUT. The result is the value D/A-READOUT1.

Now, set the system to calibration point 2, read the register D/A-READOUT again, and get the value D/A-READOUT2.

With these values and the target values V_{OUT1} and V_{OUT2} , for the calibration points 1 and 2, respectively, the values for Sensitivity and V_{OQ} are calculated as:

$$\text{Sensitivity} = \text{Sens}_{\text{INITIAL}} \times \frac{(V_{\text{out2}} - V_{\text{out1}})}{(D/A\text{-Readout2} - D/A\text{-Readout1})} \times \frac{16383}{5}$$

$$V_{\text{Oq}} = V_{\text{out2}} - \left[\left(\frac{5 \times D/A\text{-Readout2}}{16383} - V_{\text{Oq}_{\text{INITIAL}}} \right) \times \frac{\text{Sensitivity}}{\text{Sensitivity}_{\text{INITIAL}}} \right]$$

This calculation has to be done individually for each sensor.

Next, write the calculated values for Sensitivity and V_{OQ} into the IC for adjusting the sensor. At that time it is also possible to store the application specific values for Clamp-Low and Clamp-High into the sensors EEPROM. The sensor is now calibrated for the customer application. However, the programming can be changed again and again if necessary.

Note For a recalibration, the calibration procedure has to be started at the beginning (step 1). A new initialization is necessary, as the initial values from step 1 are overwritten in step 4.

Step 5: Locking the Sensor

The last step is activating the LOCK function by programming the LOCK bit. Please note that the LOCK function becomes effective after power-down and power-up of the Hall IC. The sensor is now locked and does not respond to any programming or reading commands.

Note It is mandatory to lock the sensor.

Warning This register can not be reset!

4. Specifications

4.1. Outline Dimensions

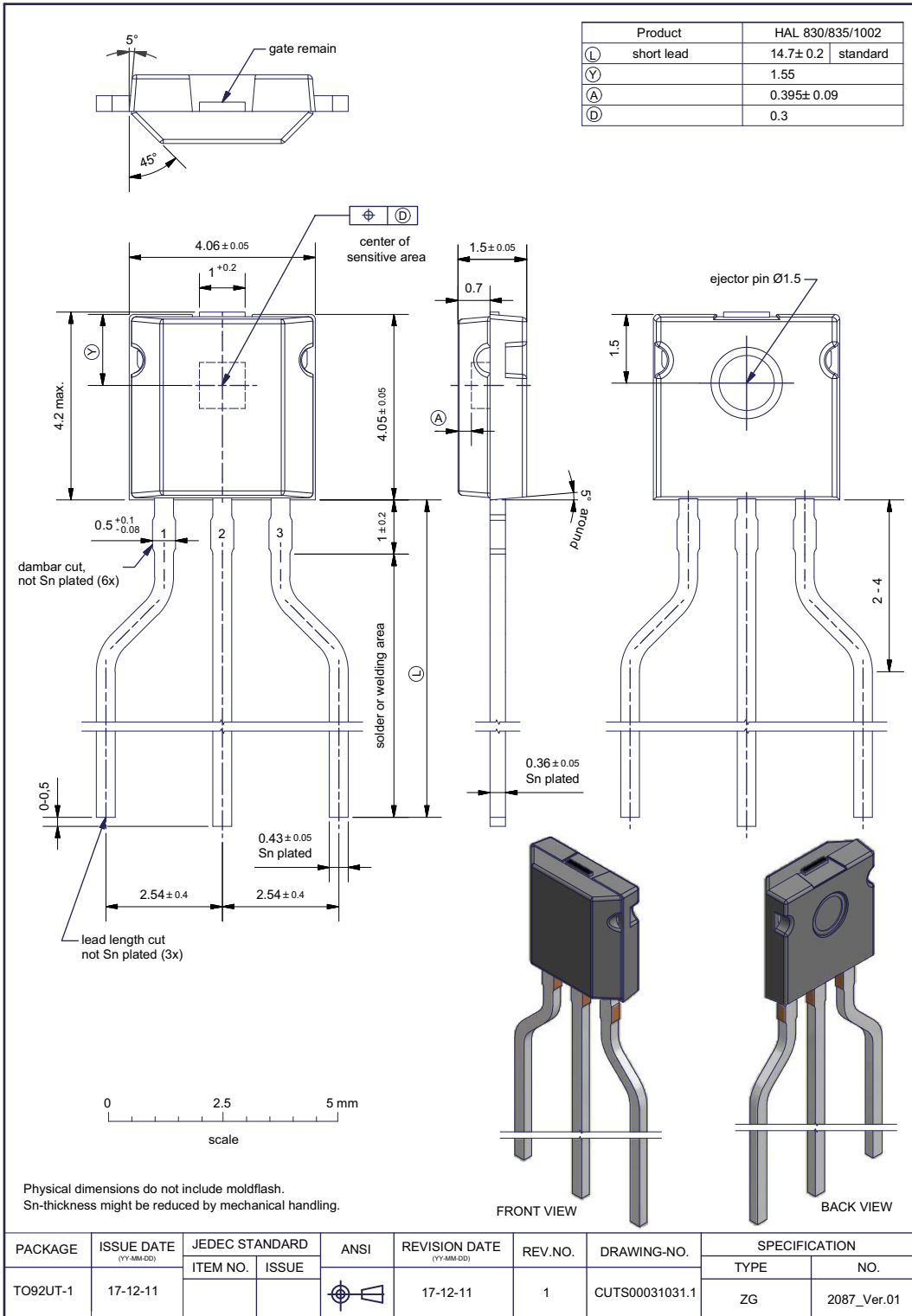

Physical dimensions do not include moldflash.
Sn-thickness might be reduced by mechanical handling.

PACKAGE	ISSUE DATE (YY-MM-DD)	JEDEC STANDARD		ANSI	REVISION DATE (YY-MM-DD)	REV.NO.	DRAWING-NO.	SPECIFICATION	
		ITEM NO.	ISSUE					TYPE	NO.
TO92UT-1	17-12-11				17-12-11	1	CUTS00031031.1	ZG	2087_Ver.01

© Copyright 2016 TDK-Micronas GmbH, all rights reserved

Fig. 4-1:
TO92UT-1 Plastic Transistor Standard UT package, 3 leads, spread
Weight approximately 0.12 g

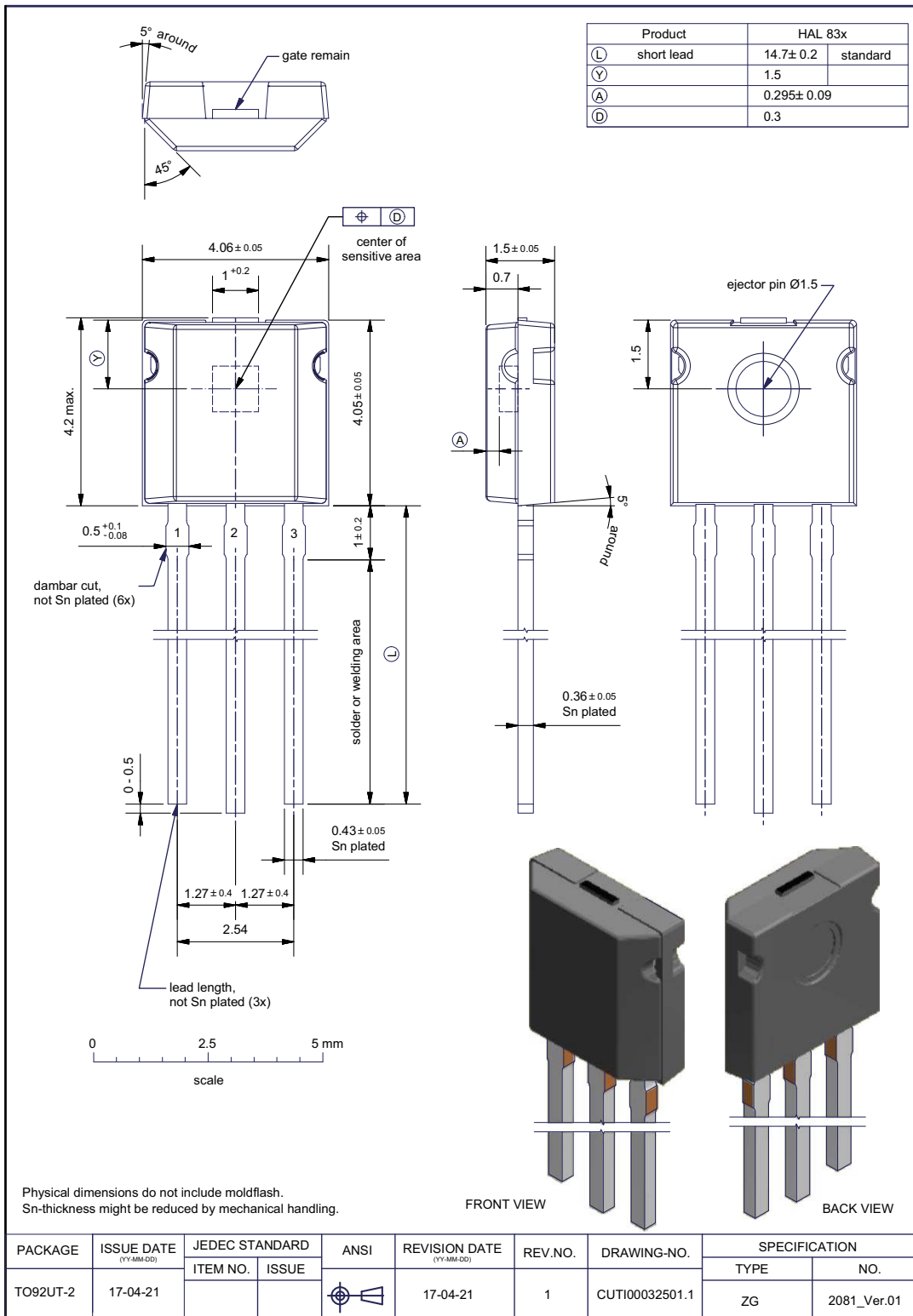

Fig. 4-2:
TO92UT-2 Plastic Transistor Standard UT package, 3 pins
 Weight approximately 0.12 g

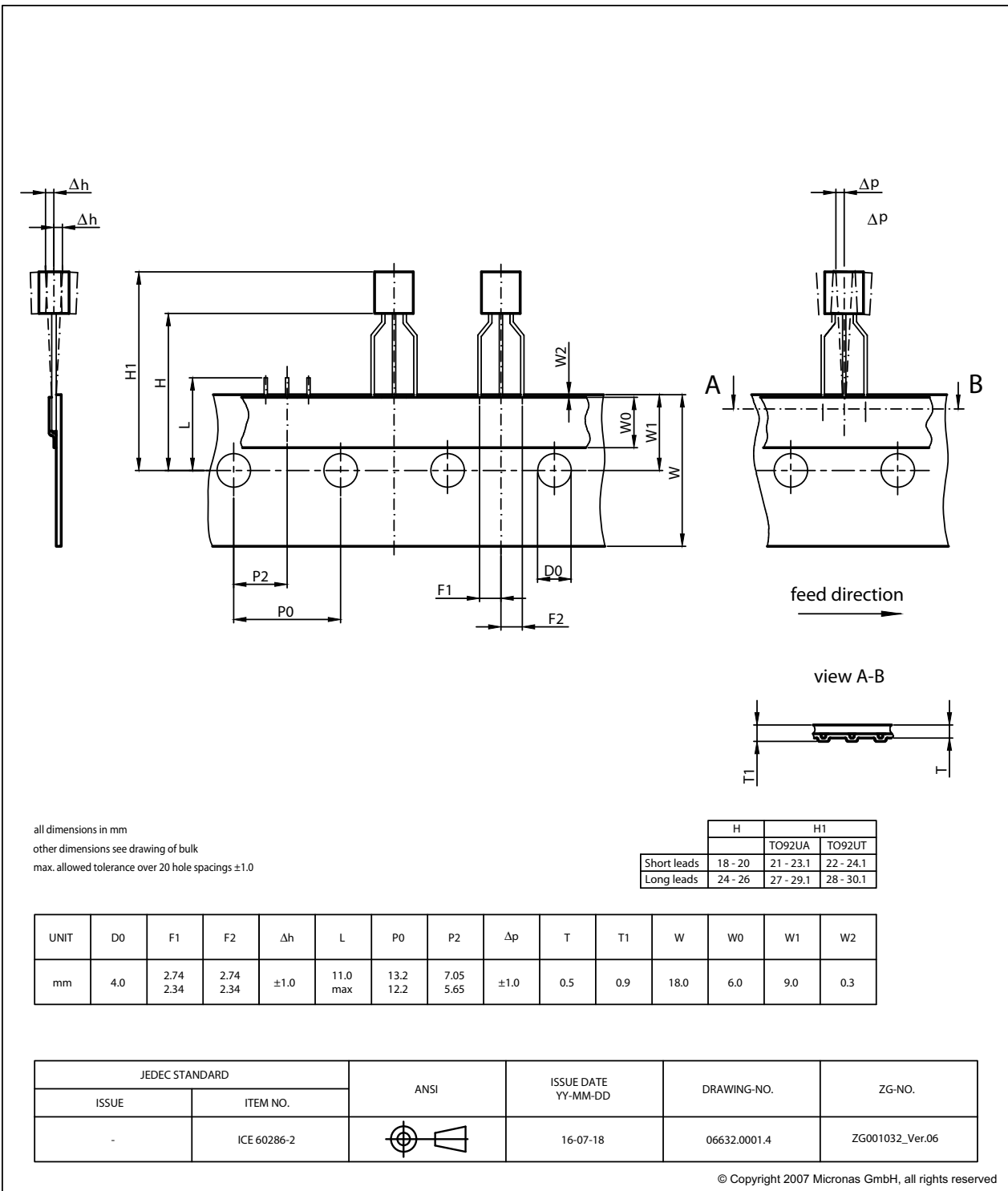

Fig. 4-3:
TO92UA/UT: Dimensions ammpack inline, spread

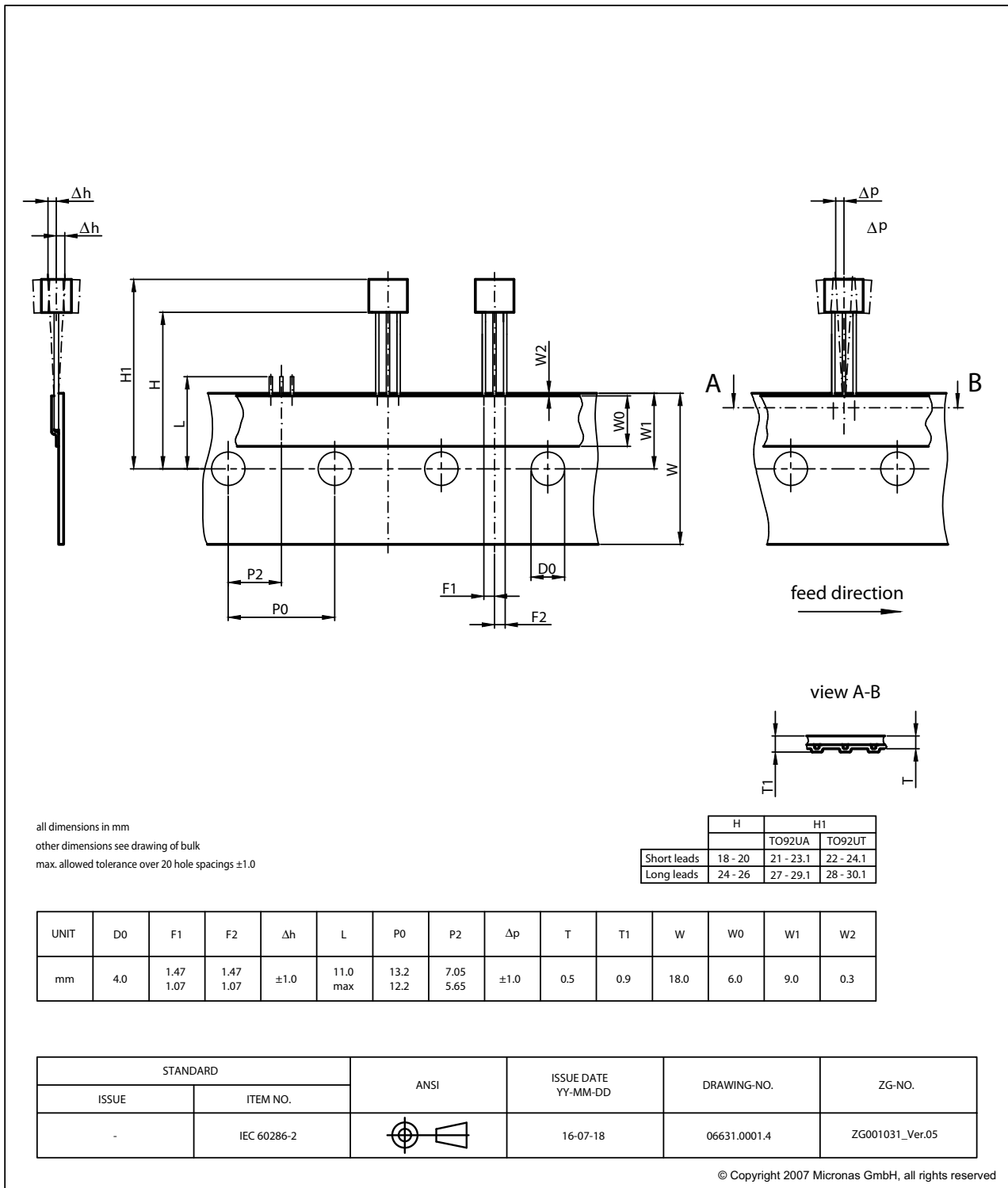

Fig. 4-4:
TO92UA/UT: Dimensions ammpack inline, not spread

4.2. Soldering, Welding and Assembly

Information related to solderability, welding, assembly, and second-level packaging is included in the document “Guidelines for the Assembly of Micronas Packages”.

It is available on the TDK-Micronas website (<https://www.micronas.com/en/service-center/downloads>) or on the service portal (<https://service.micronas.com>).

4.3. Pin Connections and Short Descriptions

Table 4–1: Pin Connection and Short Description

Pin No.	Pin Name	Type	Short Description
1	VSUP	SUPPLY	Supply Voltage and Programming Pin
2	GND	GND	Ground
3	OUT	I/O	Push-Pull Output and Selection Pin

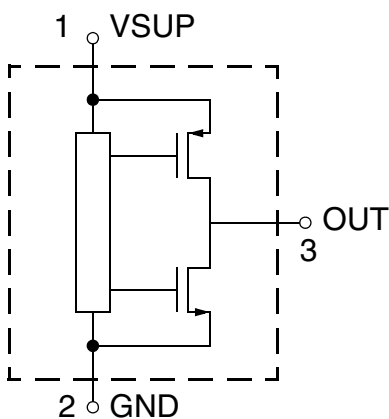

Fig. 4–5: Pin configuration

4.4. Dimensions of Sensitive Area

0.25 mm x 0.25 mm

4.5. Absolute Maximum Ratings

Stresses beyond those listed in the “Absolute Maximum Ratings” may cause permanent damage to the device. This is a stress rating only. Functional operation of the device at these conditions is not implied. Exposure to absolute maximum rating conditions for extended periods will affect device reliability.

This device contains circuitry to protect the inputs and outputs against damage due to high static voltages or electric fields; however, it is advised that normal precautions be taken to avoid application of any voltage higher than absolute maximum-rated voltages to this circuit.

All voltages listed are referenced to ground (GND).

Table 4–2: Absolute Maximum Ratings

Symbol	Parameter	Pin No.	Min.	Max.	Unit	Condition
V _{SUP}	Supply Voltage	1	–8.5	8.5	V	t < 96 h ³⁾⁴⁾
V _{SUP}	Supply Voltage	1	–16	16	V	t < 1 h ³⁾⁴⁾
V _{OUT}	Output Voltage	3	–5	16	V	
V _{OUT} – V _{SUP}	Excess of Output Voltage over Supply Voltage	3,1	–	2	V	
I _{OUT}	Continuous Output Current	3	–10	10	mA	
t _{Sh}	Output Short Circuit Duration	3	–	10	min	
V _{ESD}	ESD Protection ¹⁾	1 3	–8 –7.5	8 7.5	kV	
T _J	Junction Temperature under bias ²⁾		–50	190	°C	
t _{NVMLife}	EEPROM	–	25	–	years	T _A = 85°C
T _{storage}	Transportation/Short Term Storage Temperature		–55	150	°C	Device only without packing material

¹⁾ AEC-Q100-002 (100 pF and 1.5 kΩ)
²⁾ For 96 h - Please contact TDK-Micronas for other temperature requirements
³⁾ No cumulated stress
⁴⁾ As long as T_J is not exceeded

4.6. Storage and Shelf Life

Information related to storage conditions of Micronas sensors is included in the document “Guidelines for the Assembly of Micronas Packages”. It gives recommendations linked to moisture sensitivity level and long-term storage.

It is available on the TDK-Micronas website (<https://www.micronas.com/en/service-center/downloads>) or on the service portal (<https://service.micronas.com>).

4.7. Recommended Operating Conditions

Functional operation of the device beyond those indicated in the “Recommended Operating Conditions/Characteristics” is not implied and may result in unpredictable behavior, reduce reliability and lifetime of the device.

All voltages listed are referenced to ground (GND).

Table 4–3: Recommended Operating Conditions

Symbol	Parameter	Pin No.	Min.	Typ.	Max.	Unit	Condition
V _{SUP}	Supply Voltage	1	4.5 12.4	5 12.5	5.5 12.6	V	During programming
I _{OUT}	Continuous Output Current	3	-1.2	-	1.2	mA	
R _L	Load Resistor	3	4.5	10	-	kΩ	Can be pull-up or pull-down resistor
C _L	Load Capacitance	3	0	100	1000	nF	Analog output only
C _P	Protection Capacitor	1-2	0.33	100	2700	nF	
N _{PRG}	Number of EEPROM Programming Cycles	-	-	-	100	cycles	0°C < T _{amb} < 55°C
T _J	Junction Temperature Range ¹⁾	-	-40 -40 -40	- - -	125 150 170	°C °C °C	for 8000 h ²⁾ for 2000 h ²⁾ for 1000 h ²⁾

¹⁾ Depends on the temperature profile of the application. Please contact TDK-Micronas for life time calculations.
²⁾ Time values are not cumulative

4.8. Characteristics

at $T_J = -40\text{ °C}$ to 170 °C , $V_{SUP} = 4.5\text{ V}$ to 5.5 V , $GND = 0\text{ V}$ after programming and locking, at Recommended Operation Conditions if not otherwise specified in the column "Conditions".

Typical Characteristics for $T_J = 25\text{ °C}$ and $V_{SUP} = 5\text{ V}$.

Table 4–4: Characteristics

Symbol	Parameter	Pin No.	Min.	Typ.	Max.	Unit	Conditions
General							
I_{SUP}	Supply Current over Temperature Range	1	5	7	10	mA	
R_{OUT}	Output Resistance over Recommended Operating Range	3	–	1	10	Ω	$V_{OUTLmax} \leq V_{OUT} \leq V_{OUTHmin}$ Guaranteed by Design 100% tested
f_{OSC}	Oscillator Frequency	–	110	128	150	kHz	512 kHz internally 100% tested
BW	Small Signal Bandwidth (–3 dB)	3	–	2	–	kHz	$B_{AC} < 10\text{ mT}$; 3 dB Filter frequency = 2 kHz
Basics							
VOQ	Voltage at Output Quiet Mode	3	2.46	2.48	2.5	V	$B = 0\text{ mT}$, $I_{OUT} = 0\text{ mA}$, $T_J = 25\text{ °C}$ $f_{3dB} = 1000\text{ Hz}$, $B_{Range} = 30\text{ mT}$, $Voq = 2.5\text{ V}$, Sensitivity = 0.6 unadjusted sensor delivery status based on characterisation
Sensitivity		3	80	90	100	mV/mT	With SENSITIVITY = 1 $Voq = 2.5\text{ V}$ Magnetic range = $\pm 60\text{ mT}$ 3 dB frequency = 500 Hz TC = 15 TCSQ = 1 TC-Range = $-500 \dots +450\text{ ppm/K}$
Overall Performance							
INL	Non-Linearity of Output Voltage over Temperature	3	–0.5	0	0.5	%	% of supply voltage ¹⁾ For $V_{OUT} = 0.35\text{ V} \dots 4.65\text{ V}$; $V_{SUP} = 5\text{ V}$, Sensitivity ≤ 0.95
Dev- V_{OUT}	Deviation of Output Voltage over Temperature	3	–30	0	30	mV	
V_{OUTn}	Noise Output Voltage _{RMS}	3	–	0.6	1.4	mV	Magnetic range = 60 mT 3 dB Filter frequency = 500 Hz Sensitivity ≤ 0.7 ; $C = 4.7\text{ nF}$ (V_{SUP} & V_{OUT} to GND) based on characterisation
E_R	Ratiometric Error of Output over Temperature (Error in V_{OUT} / V_{SUP})	3	–0.25	0	0.25	%	$ V_{OUT1} - V_{OUT2} > 2\text{ V}$ during calibration procedure
¹⁾ If more than 50% of the selected magnetic field range is used (Sensitivity ≤ 0.5) and the temperature compensation is suitable. $INL = V_{OUT} - V_{OUTLSF} = \text{Least Square Fit Line voltage based on } V_{OUT} \text{ measurements at a fixed temperature.}$							

Table 4–4: Characteristics, continued

Symbol	Parameter	Pin No.	Min.	Typ.	Max.	Unit	Conditions
DAC							
	Resolution	3	–	12	–	bit	Ratiometric to V_{SUP} ²⁾
DNL	Differential Non-Linearity of D/A Converter ³⁾	3	–2.0 –1.5	0 0	2.0 1.5	LSB	HAL830 HAL835 Only @ 25°C ambient temperature
Drift over temperature							
ES	Error in Magnetic Sensitivity over Temperature Range ⁴⁾	3	–4 –1	0 0	4 1	%	HAL830 HAL835 $V_{SUP} = 5\text{ V}$; 60 mT range, 3 dB frequency = 500 Hz, TC & TCSQ for linearized temperature coefficients (see Section Table 4–5: on page 32)
V_{Offset}	Offset Drift over Temperature Range $V_{OUT}(B = 0\text{ mT})_{25^\circ\text{C}} -$ $V_{OUT}(B = 0\text{ mT})_{max}$ ⁴⁾	3	–0.6 –0.2	0.25 0.1	0.6 0.2	% V_{SUP}	HAL830 HAL835 $V_{SUP} = 5\text{ V}$; 60 mT range, 3 dB frequency = 500 Hz, TC = 15, TCSQ = 1, TC-Range = 1 –0.65 < sensitivity < 0.65
²⁾ Output DAC full scale = 5 V ratiometric, Output DAC offset = 0 V, Output DAC LSB = $V_{SUP}/4096$ ³⁾ Only tested at 25°C. The specified values are test limits only. Overmolding and packaging might influence this parameter ⁴⁾ $T_{ambient} = 150^\circ\text{C}$							

4.8.1. Additional Information

Table 4–5: Additional Information

Symbol	Parameter	Pin No.	Min.	Typ.	Max.	Unit	Conditions
General							
$t_{r(O)}$	Step Response Time of Output ¹⁾	3	–	3.0 1.5 1.1 0.9	3.5 1.75 1.3 1.05	ms	3 dB Filter frequency = 80 Hz 3 dB Filter frequency = 500 Hz 3 dB Filter frequency = 1 kHz 3 dB Filter frequency = 2kHz $C_L = 10$ nF, time to 90% of final output voltage for a steplike Signal B_{step} from 0 mT to B_{max}
t_{POD}	Power-Up Time (Time to reach stable Output Voltage)	–	1.5	1.7	1.9	ms	$C_L = 10$ nF, 90% of V_{OUT}
POR_{UP}	Power-On Reset Voltage (UP)	–	3.4	–	V		
POR_{DOWN}	Power-On Reset Voltage (DOWN)	–	3.0	–	V		
DAC							
ΔV_{OUTCL}	Accuracy of Output Voltage at Clamping Low Voltage over Temperature Range	3	–15	0	15	mV	$R_L = 5$ k Ω , $V_{SUP} = 5$ V Spec values are derived from resolutions of the registers Clamp-Low/Clamp-High and the parameter Voffset
ΔV_{OUTCH}	Accuracy of Output Voltage at Clamping High Voltage over Temperature Range	3	–15	0	15	mV	
V_{OUTH}	Upper Limit of Signal Band ²⁾	3	4.65	4.8	–	V	$V_{SUP} = 5$ V, -1 mA $\leq I_{OUT} \leq 1$ mA
V_{OUTL}	Lower Limit of Signal Band ²⁾	3	–	0.2	0.35	V	$V_{SUP} = 5$ V, -1 mA $\leq I_{OUT} \leq 1$ mA
DACGE	D/A-Converter Glitch Energy	3	–	40	–	nV	³⁾
¹⁾ Guaranteed by design ²⁾ Signal Band Area with full accuracy is located between V_{OUTL} and V_{OUTH} . The sensor accuracy is reduced below V_{OUTL} and above V_{OUTH} ³⁾ The energy of the impulse injected into the analog output when the code in the D/A-Converter register changes state. This energy is normally specified as the area of the glitch in nVs							

4.8.2. PWM Output (HAL835 only)

Table 4–6: PWM Output (HAL835 only)

Symbol	Parameter	Pin No.	Min.	Typ.	Max.	Unit	Conditions
	Resolution	3	–	11	–	bit	
$\Delta DC_{MIN-DUTY}$	Accuracy of Duty Cycle at Clamp Low over Temperature Range	3	–0.3	0	0.3	%	Spec values are derived from resolutions of the registers Clamp-Low/Clamp-High and the parameter $DC_{OQoffset}$
$\Delta DC_{MAX-DUTY}$	Accuracy of Duty Cycle at Clamp High over Temperature Range	3	–0.3	0	0.3	%	
V_{OUTH}	Output High Voltage	3	–	4.8	–	V	$V_{SUP} = 5\text{ V}, -1\text{ mA} \leq I_{OUT} \leq 1\text{ mA}$
V_{OUTL}	Output Low Voltage	3	–	0.2	–	V	$V_{SUP} = 5\text{ V}, -1\text{ mA} \leq I_{OUT} \leq 1\text{ mA}$
f_{PWM}	PWM Output Frequency over Temperature Range	3	105	125	145	Hz	
t_{POD}	Power-Up Time (Time to reach valid Duty Cycle)	3	–	–	8.5	ms	
$t_{r(O)}$	Step Response Time of Output	3	–	3 0,9 0,6 0,4	13 1,2 0,8 0,5	ms	3 dB Filter frequency = 80 Hz 3 dB Filter frequency = 500 Hz 3 dB Filter frequency = 1 kHz 3 dB Filter frequency = 2kHz Time to 90% of final output voltage for a steplike signal B_{step} from 0 mT to B_{max}

4.8.3. TO92UT Packages

Table 4–7: TO92UT Packages

Symbol	Parameter	Pin No.	Min.	Typ.	Max.	Unit	Conditions
R_{thja}	Thermal Resistance junction to air	–	–	–	235	K/W	Determined with a 1s0p board
R_{thjc}	Thermal Resistance junction to case	–	–	–	61	K/W	Determined with a 1s0p board

4.8.4. Definition of sensitivity error ES

ES is the maximum of the absolute value of the quotient of the normalized measured value¹ over the normalized ideal linear² value minus 1:

$$ES = \max \left(\left| \frac{meas}{ideal} - 1 \right| \right) \Bigg|_{\{T_{min}, T_{max}\}}$$

In the example below, the maximum error occurs at -10°C :

$$ES = \frac{1,001}{0,993} - 1 = 0.8\%$$

- ¹: normalized to achieve a least-squares method straight line that has a value of 1 at 25°C
- ²: normalized to achieve a value of 1 at 25°C

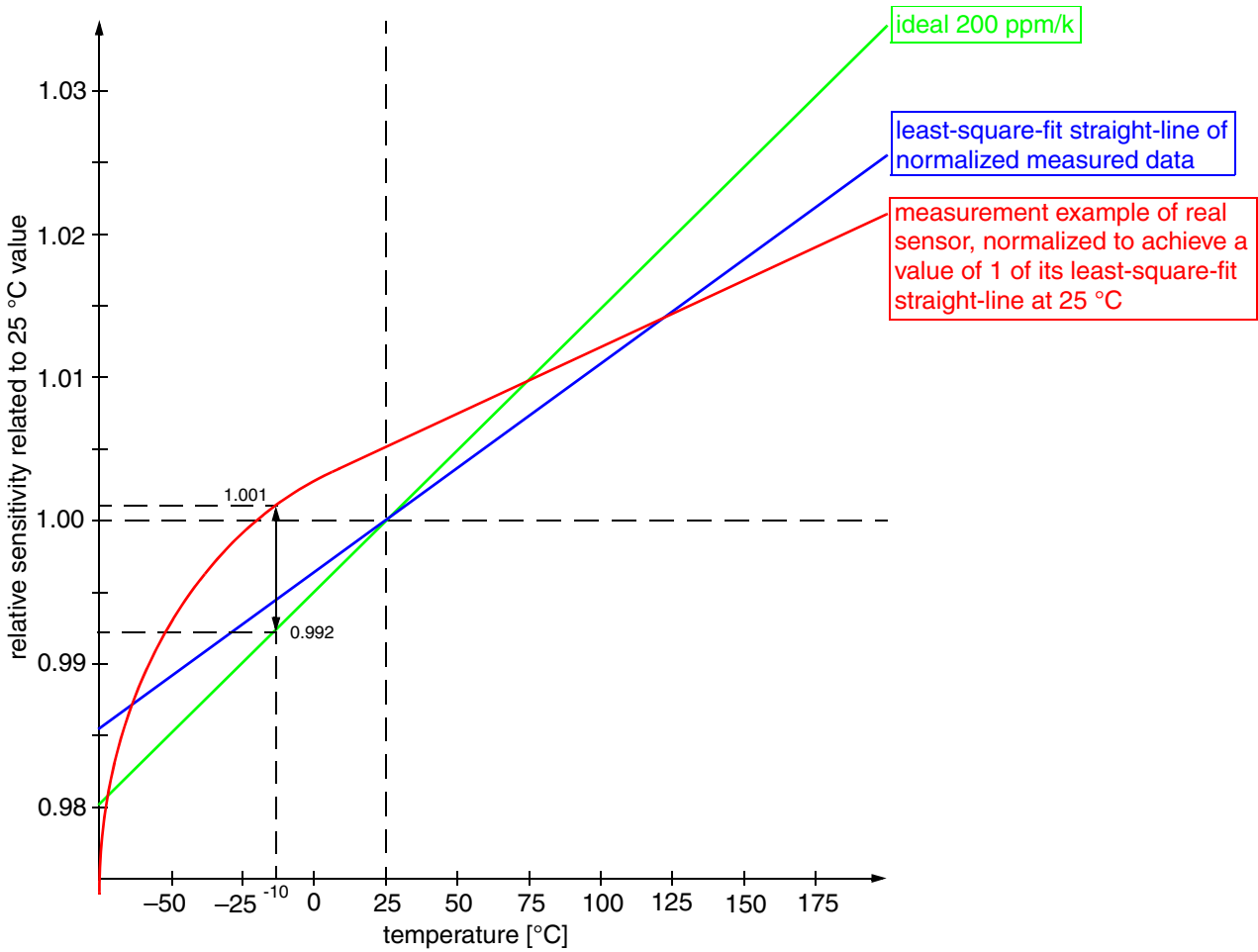

ES definition example

4.8.5. Power-On Operation

at $T_J = -40\text{ }^\circ\text{C}$ to $170\text{ }^\circ\text{C}$, after programming and locking. Typical Characteristics for $T_J = 25\text{ }^\circ\text{C}$.

Table 4–8: Power-On Operation

Symbol	Parameter	Min.	Typ.	Max.	Unit
POR_{UP}	Power-On Reset Voltage (UP)	–	3.4	–	V
POR_{DOWN}	Power-On Reset Voltage (DOWN)	–	3.0	–	V

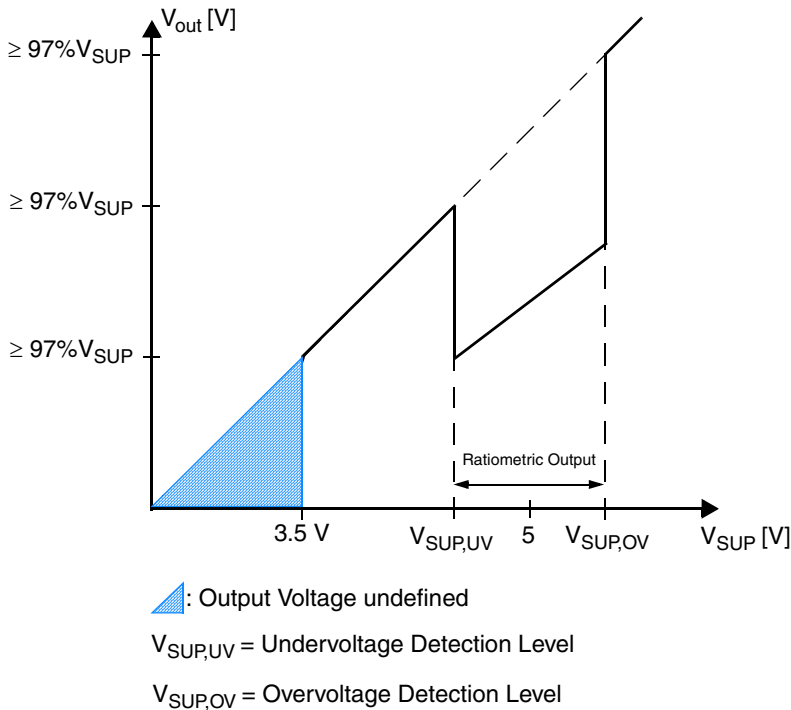

Fig. 4–6: Analog output behavior for different supply voltages

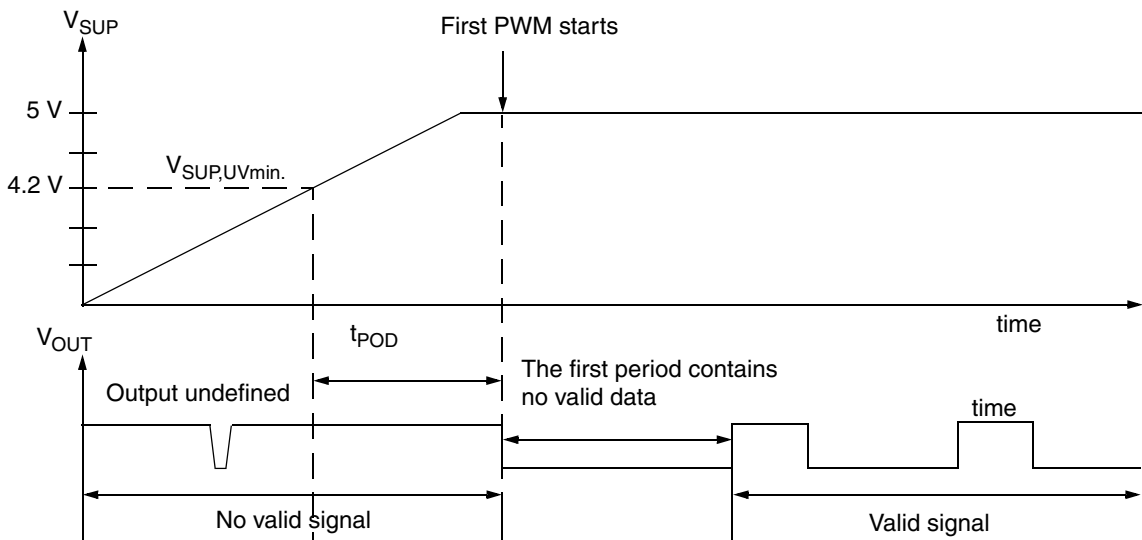

Fig. 4–7: Power-up behavior of HAL835 with PWM output activated

4.9. Diagnostics and Safety Features

4.9.1. Overvoltage and Undervoltage Detection

at $T_J = -40\text{ }^{\circ}\text{C}$ to $170\text{ }^{\circ}\text{C}$, Typical Characteristics for $T_J = 25\text{ }^{\circ}\text{C}$, after programming and locking

Table 4–9: Over-/Undervoltage Detection

Symbol	Parameter	Pin No.	Min.	Typ.	Max.	Unit	Test Conditions
$V_{SUP,UV}$	Undervoltage detection level	1	–	4.2	4.5	V	1)2)
$V_{SUP,OV}$	Overvoltage detection level	1	8.5	8.9	10.0	V	1)2)

1) If the supply voltage drops below $V_{SUP,UV}$ or rises above $V_{SUP,OV}$, the output voltage is switched to V_{SUP} ($\geq 97\%$ of V_{SUP} at $R_L = 10\text{ k}\Omega$ to GND).

2) If the PWM output of HAL835 is activated, then the output signal will follow V_{SUP} and PWM signal is switched off

Note The over- and undervoltage detection is activated only after locking the sensor!

4.9.2. Open-Circuit Detection

at $T_J = -40\text{ }^{\circ}\text{C}$ to $170\text{ }^{\circ}\text{C}$, Typical Characteristics for $T_J = 25\text{ }^{\circ}\text{C}$, after locking the sensor.

Table 4–10: Open-Circuit Detection

Symbol	Parameter	Pin No.	Min.	Typ.	Max.	Unit	Comment
V_{OUT}	Output voltage at open V_{SUP} line	3	0	0	0.15	V	$V_{SUP} = 5\text{ V}$ $R_L = 10\text{ k}\Omega$ to $200\text{ k}\Omega$
			0	0	0.2	V	$V_{SUP} = 5\text{ V}$ $5\text{ k}\Omega \leq R_L < 10\text{ k}\Omega$
			0	0	0.25	V	$V_{SUP} = 5\text{ V}$ $4.5\text{ k}\Omega \leq R_L < 10\text{ k}\Omega$ ¹⁾
V_{OUT}	Output voltage at open GND line	3	4.85	4.9	5.0	V	$V_{SUP} = 5\text{ V}$ $R_L = 10\text{ k}\Omega$ to $200\text{ k}\Omega$
			4.8	4.9	5.0	V	$V_{SUP} = 5\text{ V}$ $5\text{ k}\Omega \leq R_L < 10\text{ k}\Omega$
			4.75	4.9	5.0	V	$V_{SUP} = 5\text{ V}$ $4.5\text{ k}\Omega \leq R_L < 10\text{ k}\Omega$ ¹⁾

¹⁾Characterize on small sample size, not tested.

Note In case that the PWM output mode is used the sensor will stop transmission of the PWM signal if V_{SUP} or GND lines are broken and V_{OUT} will be according to above table.

4.9.3. Overtemperature and Short-Circuit Protection

If overtemperature $>180\text{ °C}$ or a short-circuit occurs, the output will be switched off and goes in high impedance conditions.

4.9.4. EEPROM Redundancy

The non-volatile memory except the GP registers uses the Micronas Fail Safe Redundant Cell technology well proven in automotive applications.

4.9.5. ADC Diagnostic

The A/D-READOUT register can be used to avoid under/overrange effects in the A/D converter.

5. Application Notes

5.1. Application Circuit (for analog output mode only)

For EMC protection, it is recommended to connect one ceramic 100 nF capacitor each between ground and the supply voltage, respectively the output voltage pin.

Please note that during programming, the sensor will be supplied repeatedly with the programming voltage of 12.5 V for 100 ms. All components connected to the V_{SUP} line at this time must be able to resist this voltage.

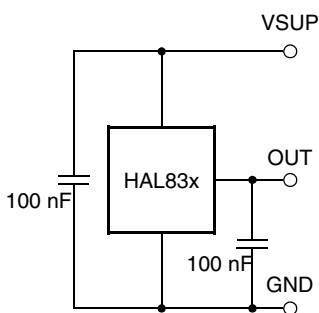

Fig. 5–1: Recommended application circuit (analog output signal)

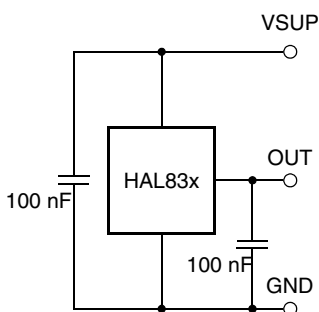

Fig. 5–2: Recommended application circuit (PWM output signal)

5.2. Use of two HAL83x in Parallel (for analog output mode only)

Two different HAL83x sensors which are operated in parallel to the same supply and ground line can be programmed individually. In order to select the IC which should be programmed, both Hall ICs are inactivated by the “Deactivate” command on the common supply line. Then, the appropriate IC is activated by an “Activate” pulse on its output. Only the activated sensor will react to all following read, write, and program commands. If the second IC has to be programmed, the “Deactivate” command is sent again, and the second IC can be selected.

Note The multi-programming of two sensors requires a 10 k Ω pull-down resistor on the sensors output pins.

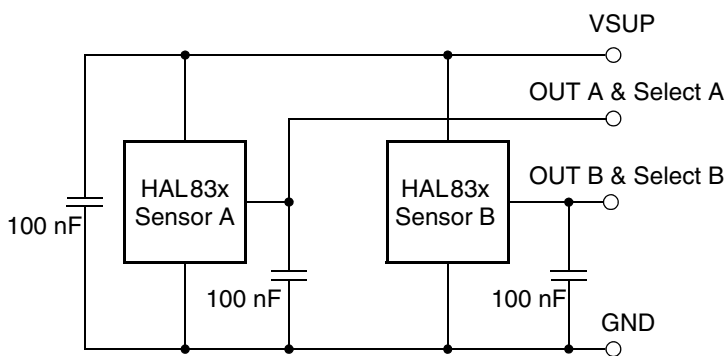

Fig. 5–3: Recommended Application circuit (parallel operation of two HAL83x)

5.3. Temperature Compensation

The relationship between the temperature coefficient of the magnet and the corresponding TC, TCSQ and TC-Range codes for linear compensation is given in the following table. In addition to the linear change of the magnetic field with temperature, the curvature can be adjusted as well. For this purpose, other TC, TCSQ and TC-Range combinations are required which are not shown in the table. Please contact TDK-Micronas for more detailed information on this higher order temperature compensation.

Table 5–1: Temperature Compensation

Temperature Coefficient of Magnet (ppm/K)	TC-Range Group	TC	TCSQ
1075	3	31	7
1000	3	28	1
900	3	24	0
750	3	16	2
675	3	12	2
575	3	8	2
450	3	4	2
400	1	31	0
250	1	24	1
150	1	20	1
50	1	16	2
0	1	15	1
-100	1	12	0
-200	1	8	1
-300	1	4	4
-400	1	0	7
-500	1	0	0
-600	2	31	2
-700	2	28	1
-800	2	24	3
-900	2	20	6
-1000	2	16	7
-1100	2	16	2

Table 5–1: Temperature Compensation, continued

Temperature Coefficient of Magnet (ppm/K)	TC-Range Group	TC	TCSQ
-1200	2	12	5
-1300	2	12	0
-1400	2	8	3
-1500	2	4	7
-1600	2	4	1
-1700	2	0	6
-1800	0	31	6
-1900	0	28	7
-2000	0	28	2
-2100	0	24	6
-2200	0	24	1
-2400	0	20	0
-2500	0	16	5
-2600	0	14	5
-2800	0	12	1
-2900	0	8	6
-3000	0	8	3
-3100	0	4	7
-3300	0	4	1
-3500	0	0	4

Note The above table shows only some approximate values. TDK-Micronas recommends to use the TC-Calc software to find optimal settings for temperature coefficients. Please contact TDK-Micronas for more detailed information.

Note Please be aware that TC-Range Group 0 and 2 are not valid in the 15 mT magnetic range.

5.4. Ambient Temperature

Due to the internal power dissipation, the temperature on the silicon chip (junction temperature T_J) is higher than the temperature outside the package (ambient temperature T_A).

$$T_J = T_A + \Delta T$$

At static conditions and continuous operation, the following equation applies:

$$\Delta T = I_{SUP} * V_{SUP} * R_{thjX}$$

The X represents junction-to-air or junction-to-case.

In order to estimate the temperature difference ΔT between the junction and the respective reference (e.g. air, case, or solder point) use the max. parameters for I_{SUP} , R_{thX} , and the max. value for V_{SUP} from the application.

The following example shows the result for junction-to-air conditions. $V_{SUP} = 5.5$ V, $R_{thja} = 250$ K/W and $I_{SUP} = 10$ mA the temperature difference $\Delta T = 13.75$ K.

The junction temperature T_J is specified. The maximum ambient temperature T_{Amax} can be estimated as:

$$T_{Amax} = T_{Jmax} - \Delta T$$

5.5. EMC and ESD

Please contact TDK-Micronas for the detailed investigation reports with the EMC and ESD results.

■ EMC results are only valid for locked devices.

6. Programming

6.1. Definition of Programming Pulses

The sensor is addressed by modulating a serial telegram on the supply voltage. The sensor answers with a serial telegram on the output pin.

The bits in the serial telegram have a different bit time for the V_{SUP} -line and the output. The bit time for the V_{SUP} -line is defined through the length of the Sync Bit at the beginning of each telegram. The bit time for the output is defined through the Acknowledge Bit.

A logical “0” is coded as no voltage change within the bit time. A logical “1” is coded as a voltage change between 50% and 80% of the bit time. After each bit, a voltage change occurs.

6.2. Definition of the Telegram

Each telegram starts with the Sync Bit (logical 0), 3 bits for the Command (COM), the Command Parity Bit (CP), 4 bits for the Address (ADR), and the Address Parity Bit (AP).

There are 4 kinds of telegrams:

- Write a register (see Fig. 6–2)
After the AP Bit, follow 14 Data Bits (DAT) and the Data Parity Bit (DP). If the telegram is valid and the command has been processed, the sensor answers with an Acknowledge Bit (logical 0) on the output.
- Read a register (see Fig. 6–3)
After evaluating this command, the sensor answers with the Acknowledge Bit, 14 Data Bits, and the Data Parity Bit on the output.
- Programming the EEPROM cells (see Fig. 6–4)
After evaluating this command, the sensor answers with the Acknowledge Bit. After the delay time t_w , the supply voltage rises up to the programming voltage.
- Activate a sensor (see Fig. 6–5)
If more than one sensor is connected to the supply line, selection can be done by first deactivating all sensors. The output of all sensors have to be pulled to ground. With an Activate pulse on the appropriate output pin, an individual sensor can be selected. All following commands will only be accepted from the activated sensor.

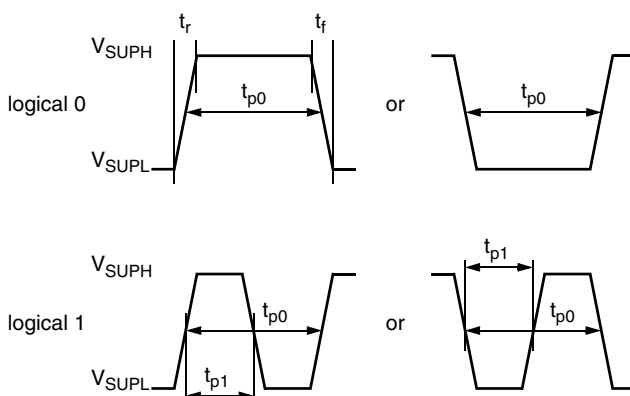

Fig. 6–1: Definition of logical 0 and 1 bit

Table 6–1: Telegram parameters

Symbol	Parameter	Pin	Min.	Typ.	Max.	Unit	Remarks
V_{SUPL}	Supply Voltage for Low Level during Programming	1	5	5.6	6	V	
V_{SUPH}	Supply Voltage for High Level during Programming	1	6.8	8.0	8.5	V	
t_r	Rise time	1	–	–	0.05	ms	see Fig. 6–1 on page 43
t_f	Fall time	1	–	–	0.05	ms	see Fig. 6–1 on page 43
t_{p0}	Bit time on V_{SUP}	1	1.7	1.8	1.9	ms	t_{p0} is defined through the Sync Bit
t_{pOUT}	Bit time on output pin	3	2	3	4	ms	t_{pOUT} is defined through the Acknowledge Bit
t_{p1}	Duty-Cycle Change for logical 1	1, 3	50	65	80	%	% of t_{p0} or t_{pOUT}
$V_{SUPPROG}$	Supply Voltage for Programming the EEPROM	1	12.4	12.5	12.6	V	
t_{PROG}	Programming Time for EEPROM	1	95	100	105	ms	
t_{rp}	Rise time of programming voltage	1	0.2	0.5	1	ms	see Fig. 6–1 on page 43
t_{fp}	Fall time of programming voltage	1	0	–	1	ms	see Fig. 6–1 on page 43
t_w	Delay time of programming voltage after Acknowledge	1	0.5	0.7	1	ms	
V_{act}	Voltage for an Activate pulse	3	3	4	5	V	
t_{act}	Duration of an Activate pulse	3	0.05	0.1	0.2	ms	
$V_{out,deact}$	Output voltage after deactivate command	3	0	0.1	0.2	V	

WRITE

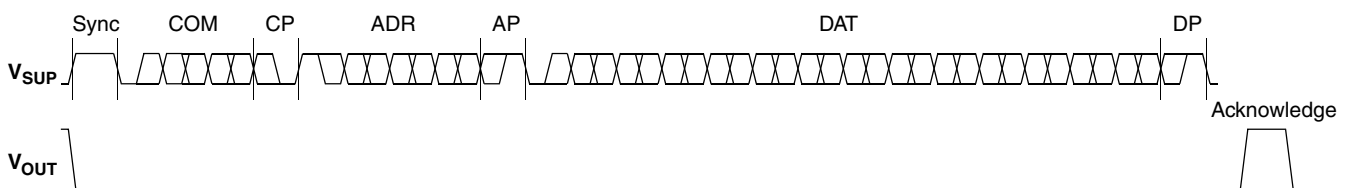

Fig. 6–2: Telegram for coding a Write command

READ

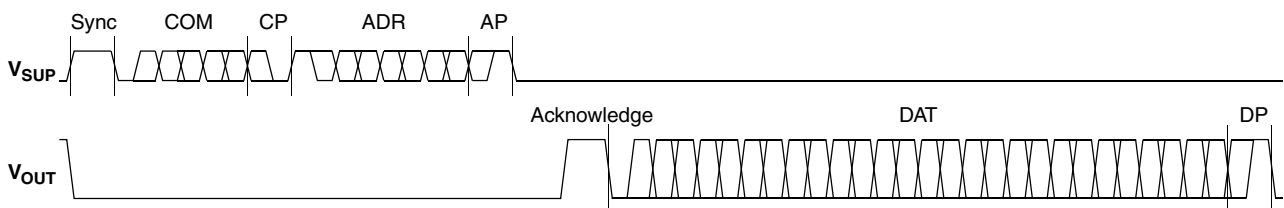

Fig. 6–3: Telegram for coding a Read command

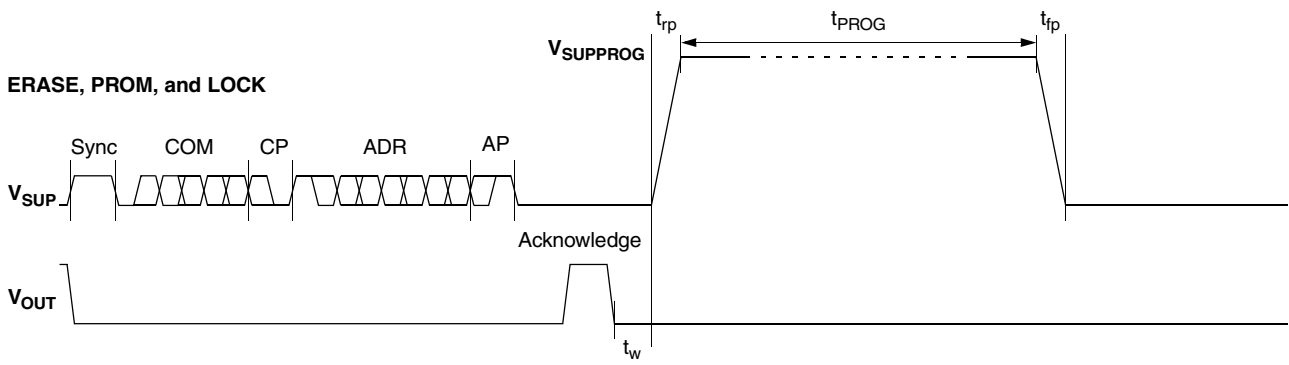

Fig. 6–4: Telegram for coding the EEPROM programming

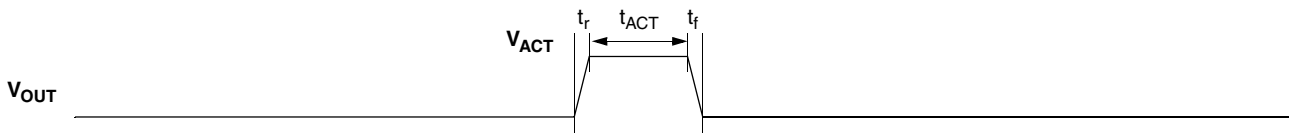

Fig. 6–5: Activate pulse

6.3. Telegram Codes

Sync Bit

Each telegram starts with the Sync Bit. This logical “0” pulse defines the exact timing for t_{p0} .

Command Bits (COM)

The Command code contains 3 bits and is a binary number. Table 6–2 shows the available commands and the corresponding codes for the HAL83x.

Command Parity Bit (CP)

This parity bit is “1” if the number of zeros within the 3 Command Bits is uneven. The parity bit is “0”, if the number of zeros is even.

Address Bits (ADR)

The Address code contains 4 bits and is a binary number. Table 6–3 shows the available addresses for the HAL83x registers.

Address Parity Bit (AP)

This parity bit is “1” if the number of zeros within the 4 Address bits is uneven. The parity bit is “0” if the number of zeros is even.

Data Bits (DAT)

The 14 Data Bits contain the register information.

The registers use different number formats for the Data Bits. These formats are explained in Section 6.4.

In the Write command, the last bits are valid. If, for example, the TC register (10 bits) is written, only the last 10 bits are valid.

In the Read command, the first bits are valid. If, for example, the TC register (10 bits) is read, only the first 10 bits are valid.

Data Parity Bit (DP)

This parity bit is “1” if the number of zeros within the binary number is even. The parity bit is “0” if the number of zeros is uneven.

Acknowledge

After each telegram, the output answers with the Acknowledge signal. This logical “0” pulse defines the exact timing for t_{pOUT} .

Table 6–2: Available commands

Command	Code	Explanation
READ	2	read a register
WRITE	3	write a register
PROM	4	program all non-volatile registers
ERASE	5	erase all non-volatile registers

6.4. Number Formats

Binary number:

The most significant bit is given as first, the least significant bit as last digit.

Example: 101001 represents 41 decimal.

Signed binary number:

The first digit represents the sign of the following binary number (1 for negative, 0 for positive sign).

Example: 0101001 represents +41 decimal

1101001 represents –41 decimal

Two’s-complement number:

The first digit of positive numbers is “0”, the rest of the number is a binary number. Negative numbers start with “1”. In order to calculate the absolute value of the number, calculate the complement of the remaining digits and add “1”.

Example: 0101001 represents +41 decimal

1010111 represents –41 decimal

6.5. Register Information

CLAMP-LOW

- The register range is from 0 up to 255.
- The register value is calculated by:

$$\text{CLAMP-LOW} = \frac{\text{LowClampingVoltage} \times 2}{V_{SUP}} \times 255$$

CLAMP-HIGH

- The register range is from 0 up to 511.
- The register value is calculated by:

$$\text{CLAMP-HIGH} = \frac{\text{HighClampingVoltage}}{V_{SUP}} \times 511$$

VOQ

- The register range is from –1024 up to 1023.
- The register value is calculated by:

$$\text{VOQ} = \frac{V_{OQ}}{V_{SUP}} \times 1024$$

SENSITIVITY

- The register range is from –8192 up to 8191.
- The register value is calculated by:

$$\text{SENSITIVITY} = \text{Sensitivity} \times 2048$$

TC

- The TC register range is from 0 up to 1023.
- The register value is calculated by:

$$\text{TC} = \text{GROUP} \times 256 + \text{TCValue} \times 8 + \text{TCSQValue}$$

MODE

- The register range is from 0 up to 1023 and contains the settings for FILTER, RANGE, OUTPUTMODE:

$$\begin{aligned} \text{MODE} = & \text{RANGE}(\text{Mode}[9]) \times 512 + \\ & \text{OUTPUTMODE} \times 32 + \\ & \text{FILTER} \times 8 + \text{RANGE}(\text{Mode}[2:1]) \times 2 \end{aligned}$$

D/A-READOUT

- This register is read only.
- The register range is from 0 up to 16383.

DEACTIVATE

- This register can only be written.
- The register has to be written with 2063 decimal (80F hexadecimal) for the deactivation.
- The sensor can be reset with an Activate pulse on the output pin or by switching off and on the supply voltage.

Table 6–3: Available register addresses

Register	Code	Data Bits	Format	Customer	Remark
CLAMP-LOW	1	8	binary	read/write/ program	Low clamping voltage
CLAMP-HIGH	2	9	binary	read/write/ program	High clamping voltage
VOQ	3	11	two's compl. binary	read/write/ program	Output quiescent voltage
SENSITIVITY	4	14	signed binary	read/write/ program	
MODE	5	10	binary	read/write/ program	Range, filter, output mode
LOCKR	6	2	binary	read/write/ program	Lock Bit
A/D READOUT	7	14	two's compl. binary	read	
GP REGISTERS 1...3	8	3x13	binary	read/write/ program	1)

Table 6–3: Available register addresses, continued

Register	Code	Data Bits	Format	Customer	Remark
D/A-READOUT	9	14	binary	read	Bit sequence is reversed during read
TC	11	10	binary	read/write/ program	bits 0 to 2 TCSQ bits 3 to 7 TC bits 8 to 9 TC Range
GP REGISTER 0	12	13	binary	read/write/ program	1)
DEACTIVATE	15	12	binary	write	Deactivate the sensor

1) To read/write this register it is mandatory to read/write all GP register one after the other starting with GP0. In case of a writing the registers it is necessary to first write all registers followed by one store sequence at the end. Even if only GP0 should be changed all other GP registers must first be read and the read out data must be written again to these registers.

6.6. Programming Information

Table 6–4: Data formats

Register	Char	DAT3				DAT2				DAT1				DAT0			
	Bit	15	14	13	12	11	10	9	8	7	6	5	4	3	2	1	0
CLAMP LOW	Write	–	–	–	–	–	–	–	–	V	V	V	V	V	V	V	V
	Read	–	–	V	V	V	V	V	V	V	V	–	–	–	–	–	–
CLAMP HIGH	Write	–	–	–	–	–	–	–	V	V	V	V	V	V	V	V	V
	Read	–	–	V	V	V	V	V	V	V	V	V	–	–	–	–	–
VOQ	Write	–	–	–	–	–	V	V	V	V	V	V	V	V	V	V	V
	Read	–	–	V	V	V	V	V	V	V	V	V	V	V	–	–	–
SENSITIVITY	Write	–	–	V	V	V	V	V	V	V	V	V	V	V	V	V	V
	Read	–	–	V	V	V	V	V	V	V	V	V	V	V	V	V	V
MODE	Write	–	–	–	–	–	–	V	V	V	V	V	V	V	V	V	V
	Read	–	–	V	V	V	V	V	V	V	V	V	V	–	–	–	–
A/D-READOUT	Read	–	–	V	V	V	V	V	V	V	V	V	V	V	V	V	V
LOCKR	Write	–	–	–	–	–	–	–	–	–	–	–	–	–	–	–	V
	Read	–	–	–	V	–	–	–	–	–	–	–	–	–	–	–	–
GP 1...3 Registers	Write	–	–	–	V	V	V	V	V	V	V	V	V	V	V	V	V
	Read	–	–	V	V	V	V	V	V	V	V	V	V	V	V	V	–
D/A-READOUT ¹⁾	Read	–	–	V	V	V	V	V	V	V	V	V	V	V	V	V	V
TC	Write	–	–	–	–	–	–	V	V	V	V	V	V	V	V	V	V
	Read	–	–	V	V	V	V	V	V	V	V	V	V	–	–	–	–
GP 0 Register	Write	–	–	–	V	V	V	V	V	V	V	V	V	V	V	V	V
	Read	–	–	V	V	V	V	V	V	V	V	V	V	V	V	V	–
DEACTIVATE	Write	–	–	–	–	1	0	0	0	0	0	0	0	1	1	1	1

V: valid, –: ignore, bit order: MSB first
¹⁾ LSB first

If the content of any register (except the lock registers) is to be changed, the desired value must first be written into the corresponding RAM register. Before reading out the RAM register again, the register value must be permanently stored in the EEPROM.

Permanently storing a value in the EEPROM is done by first sending an ERASE command followed by sending a PROM command. **The address within the ERASE and PROM commands must be zero.** ERASE and PROM act on all registers in parallel.

If all HAL83x registers are to be changed, all writing commands can be sent one after the other, followed by sending one ERASE and PROM command at the end.

During all communication sequences, the customer has to check if the communication with the sensor was successful. This means that the acknowledge and the parity bits sent by the sensor have to be checked by the customer. If the Micronas programmer board is used, the customer has to check the error flags sent from the programmer board.

Note

For production and qualification tests it is mandatory to set the LOCK bit after final adjustment and programming of HAL83x. The LOCK function is active after the next power-up of the sensor.

The success of the lock process must be checked by reading at least one sensor register after locking and/or by an analog check of the sensors output signal.

Electrostatic discharges (ESD) may disturb the programming pulses. Please take precautions against ESD.

7. Data Sheet History

1. Advance Information: "HAL 83x Robust Multi-Purpose Programmable Linear Hall-Effect Sensor Family", Jan. 13, 2013, AI000169_001EN. First release of the Advance Information.
2. Preliminary Data Sheet: "HAL 83x Robust Multi-Purpose Programmable Linear Hall-Effect Sensor Family", Aug. 2, 2013, PD000213_001EN. First release of the preliminary data sheet.

Major Changes:

- Absolute Maximum Ratings: Values for V_{ESD}
- Characteristics: Values for V_{Offset}

3. Preliminary Data Sheet: "HAL 83x Robust Multi-Purpose Programmable Linear Hall-Effect Sensor Family", Oct. 2, 2014, PD000213_002EN. Second release of the preliminary data sheet.

Major Changes:

- TO92 UT package drawing updated
- TO92 UT package spread legs option deleted
- Recommended operating conditions and characteristics:
- Updated DNL value for HAL 835
- Updated $R_{L_{min}}$ (load resistor)
- Diagnostics and safety features updated
- Offset correction feature for HAL 835 removed

4. Data Sheet: "HAL 83x Robust Multi-Purpose Programmable Linear Hall-Effect Sensor Family", Feb. 25, 2015, DSH000169_001E. First release of the data sheet.

Major Changes:

- Step Response Times

5. Data Sheet: "HAL 83x Robust Multi-Purpose Programmable Linear Hall-Effect Sensor Family", May 22, 2015, DSH000169_002E. Second release of the data sheet.

Major Changes:

- Package TO92UT-1 (spread) added
- Package drawing TO92UT-2 (non-spread) updated
- Ammopack drawings updated
- Assembly and storage information
- Several text corrections

6. Data Sheet: "HAL 83x Robust Multi-Purpose Programmable Linear Hall-Effect Sensor Family", March 21, 2018, DSH000169_003EN. Third release of the data sheet.

Major Changes:

- Section 3.2. added
- 40mT magnetic range in Table 3–2 and Table 3–3 removed
- Limitation for TC-Range 0 and 2 in Table 3–7
- Initial values for Sens_{INITIAL} in Table 3–8 changed
- Sensitivity equation in Fig. 3.4.1. updated
- V_{OQ} equation in Section 3.4.1. changed
- Package Drawing TO92UT-1 (spread) updated
- Package Drawing TO92UT-2 (non-spread) updated
- Ammopack Drawing TO92UT/UA (spread) updated
- Ammopack Drawing TO92UT/UA (non-spread) updated
- Section 4.2. updated
- Section 4.5 deleted
- Section 4.6.1 switched to Section 4.6. and got updated
- $t_{NVMLife}$ and $T_{storage}$ in Table 4–2 added
- C_p in Table 4–3 added
- Characteristics (Table 4–4) updated:
 - ROUT conditions
 - fOSC added
 - V_{OQ} value
 - V_{OUTn} value
 - R_{thja} conditions
 - R_{thjc} conditions
- Maximum values for $t_{r(O)}$ (Step Response Time of Output) added in Section 4.8.
- Fig. 5–1 added
- Parameter A/D-Readout in Table 6–4 added