

THIS DRAWING IS UNPUBLISHED. RELEASED FOR PUBLICATION
 © COPYRIGHT - By - ALL RIGHTS RESERVED.

REVISIONS					
P	LTR	DESCRIPTION	DATE	DWN	APVD
M		REVISED PER ECO-16-005106	05APR2016	NK	MZ
N		REVISED PER ECO-18-000435	17JAN2018	RS	MZ

- 1 FINISH- SILVER PLATE 500 μINCHES THICK MINIMUM.
- 2 FINISH- SILVER PLATE 200 μINCHES THICK MINIMUM.
- 3 FINISH- NICKEL PLATE 40 μINCHES THICK MINIMUM.
- 4 FINISH- GOLD PLATE 50 μIN MIN THICK MINIMUM.
- 5 FINISH-
- 6 PLATING NOTES ARE TO BE INTERPRETED AS FOLLOWS: 1-2 AS 1 OVER 2.
- 7 PRODUCT IS SOLD BY THE FOOT.
- 8 PRELIMINARY PART NUMBER.
- 9 FINISH- GOLD PLATE 40 μIN THICK MINIMUM.
- 10 FINISH- NICKEL PLATE 100 μIN THICK MINIMUM.
- 11 OBSOLETE
- 12 OBSOLETE PARTS: OBSOLETE CIS STREAMLINING PER D.RENAUD/D.SINISI
- 13 10 LOUVERS, NOT TO EXCEED 1.000 INCHES.

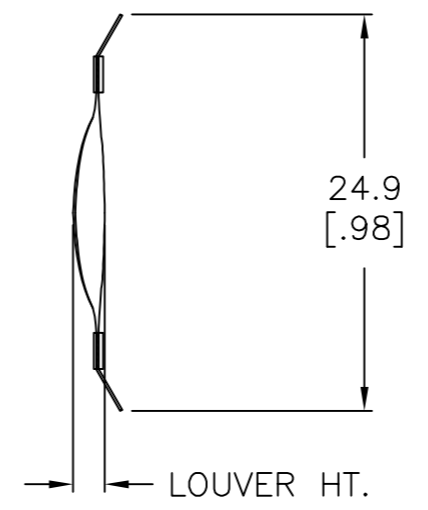
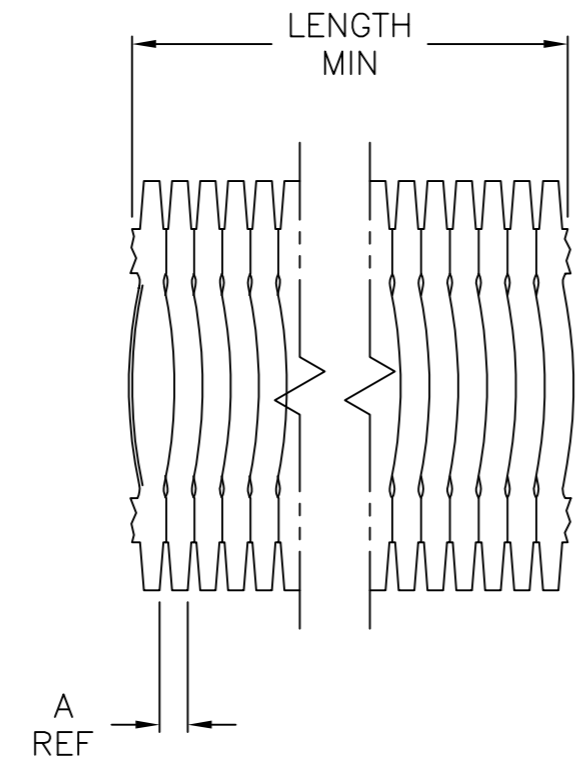

OBSOLETE			2.79 [.110]	1.90 [48.3]/2.00 [50.8]	1-3	20 MIN	0.25 [.010]	-	2-192002-0	
OBSOLETE	.100		2.75 [.110]		4-3		0.25 [.010]	-	1-192002-9	
OBSOLETE	.100		2.75 [.110]	1.00 ^{+0.01} _{-0.00}	1-3	10-11	0.25 [.010]	-	1-192002-8	
	.090		2.79 [.110]		9-10		0.25 [.010]		1-192002-7	
OBSOLETE	.100		2.67 [.105]		4-3		0.15 [.006]		1-192002-6	
			2.67 [.105]		4-3	3	0.15 [.006]		1-192002-5	
	.090		2.67 [.105]		4-3		0.15 [.006]		1-192002-4	
OBSOLETE			2.67 [.105]		1-3	3	0.15 [.006]		1-192002-3	
			2.67 [.105]		1-3		0.15 [.006]		1-192002-2	
			2.67 [.105]		4-3		0.15 [.006]		1-192002-1	
			2.79 [.110]		-	UNPL	6	0.25 [.010]	1-192002-0	
			2.79 [.110]	203.2 [8.00]	1-3		0.25 [.010]	00517	192002-9	
OBSOLETE			2.79 [.110]		1-3	4	0.25 [.010]	00513	192002-8	
	.100		2.79 [.110]		--	1-3	9	0.25 [.010]	00515	192002-7
			2.79 [.110]		--	1-3	5	0.25 [.010]	00514	192002-6
OBSOLETE			2.79 [.110]	152.4 [6.00]	1-3		0.25 [.010]	00516	192002-5	
OBSOLETE			2.79 [.110]		1-3		0.25 [.010]	00502	192002-4	
			2.79 [.110]			UNPL		0.25 [.010]	00503	192002-3
OBSOLETE			2.67 [.105]		1-3		0.15 [.006]	00501	192002-2	
OBSOLETE			2.67 [.105]			UNPL		0.15 [.006]	00500	192002-1
	A		LOUVER HT	LENGTH	PLATING (NOTE)	NUM LOUV	MAT'L THK	WAS	PART NUMBER	

THIS DRAWING IS A CONTROLLED DOCUMENT.

DIMENSIONS: mm [INCHES]

TOLERANCES UNLESS OTHERWISE SPECIFIED:

0 PLC	± -
1 PLC	± -
2 PLC	± 0.5 [.02]
3 PLC	± 0.25 [.010]
4 PLC	± -
ANGLES	± -

MATERIAL: BeCu

FINISH: SEE TABLE

CHK: S. SIEGRIST

APVD: -

PRODUCT SPEC: -

APPLICATION SPEC: -

WEIGHT: -

CUSTOMER DRAWING

DWN: -

CHK: S. SIEGRIST

APVD: -

PRODUCT SPEC: -

APPLICATION SPEC: -

WEIGHT: -

TE Connectivity

CONTACT BAND, STRIP

SIZE: A2

CAGE CODE: 00779

DRAWING NO: C=192002

RESTRICTED TO: -

SCALE: 1:1

SHEET: 1 of 1

REV: N