

REVISIONS					
REV	ECO	DESCRIPTION	DATE	BY	APPR
A1	--	RELEASED DRAWING	APR-05-2016	SULLEN	TOMMY
A2	--	UPDATE NOTES	JUN-20-2017	NICK	TOMMY
A3	--	UPDATE DRAWING	Mar-16-2018	White	Tommy

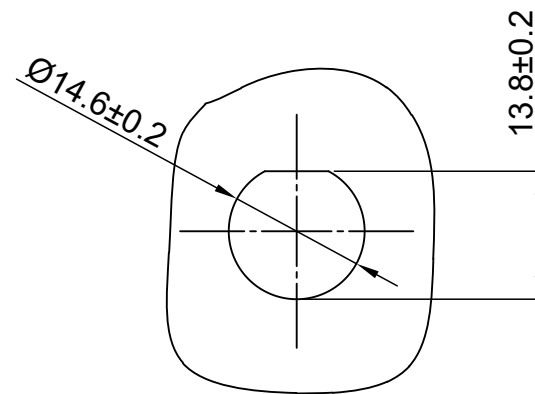
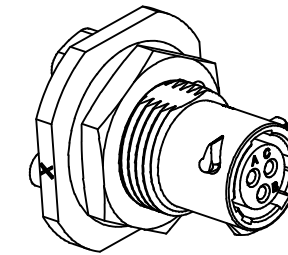
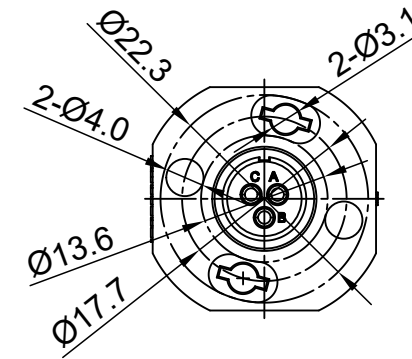
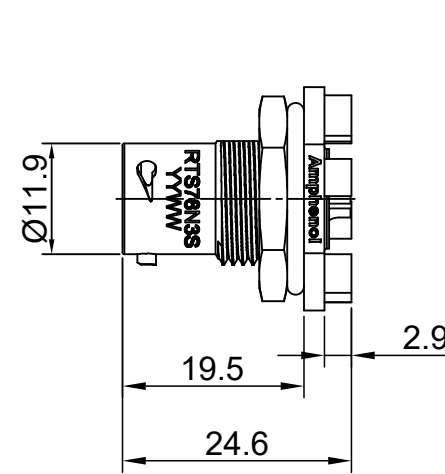
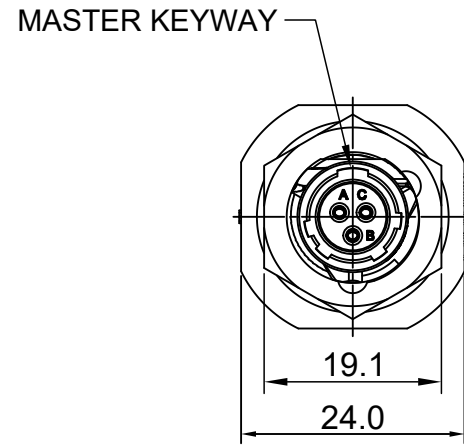

PANEL CUT OUT REFERENCE
PANEL THICKNESS : 3.2MM MAX.

KEY	PART NUMBER
N	RTS78N3S

NOTES : (UNLESS OTHERWISE SPECIFIED)

- MATERIAL :
SHELL : THERMOPLASTIC , UL94 V-0.
INSERT : CHLOROPRENE RUBBER.
O-RING : NBR.
SEAL GASKET : NBR.
JAM NUT : ALUMINIUM ALLOY , BLACK ANODIZING.
CONTACT : COPPER ALLOY , GOLD PLATED.
- SPECIFICATIONS :
2.1 RATED CURRENT : 7A (MAX).
2.2 RATED VOLTAGE : 250V(AC/DC).
2.3 OPERATING TEMPERATURE : -40°C ~ 105°C.
2.4 DIELECTRIC WITHSTANDING VOLTAGE : LESS THAN
2 MILLIAMPS CURRENT LEAKAGE@1500 VOLTS AC.
2.5 INSULATION RESISTANCE : 5000 MEGOHMS MIN.
2.6 IP--CLASS : IP67 AND IP69K IN THE MATED CONDITION,
PANEL EXTERNAL.
2.7 MATING CYCLES DURABILITY : 500 CYCLES MIN.
2.8 RoHS COMPLIANT.
- ALL DIMENSIONS ARE FOR REFERENCE USE ONLY.

QUANTITY	PART NUMBER	DESCRIPTION	ITEM
MATERIALS LIST			
UNLESS OTHERWISE SPECIFIED 1) All dimensions are in metric(mm). 2) Tolerances are as follows: 1 PL DEC ±0.30 2 PL DEC ±0.15 3 PL DEC ±0.08 3) Note reference =		SIGNATURES DRAWN: White CHECKED: Tod ENGINEER: APPROVAL: Tommy	DATE Mar-16-2018 Mar-16-2018 Mar-16-2018
MATERIAL SPECIFICATIONS:		Amphenol	
PROCESS SPECIFICATIONS:		Sine Systems - www.amphenol-sine.com 44724 Morley Drive Clinton Township, MI 48036	
NEXT ASSY:		ECO-MATE, RECEPTACLE, JAM NUT, SIZE 8,3POS, SOCKET	
THIS DRAWING IS SUPPLIED FOR INFORMATION ONLY. DESIGN FEATURES, SPECIFICATIONS AND PERFORMANCE DATA SHOWN HEREON ARE THE PROPERTY OF THE AMPHENOL CORPORATION. NO RIGHTS OF REPRODUCTION ARE IMPLIED. ALL DIMENSIONS ARE SUBJECT TO NORMAL MANUFACTURING VARIATIONS.		SIZE B C-	REVISION A3
SCALE: NONE		DWG NO: RTS78*3S	SHEET 1 OF 1

TITLE: ECO-MATE, RECEPTACLE, JAM NUT, SIZE 8,3POS, SOCKET

DWG NO:

RTS78*3S

REV: A3

SH: 1

OF: 1