

7-Axis, High Performance Integrated 6-Axis Inertial and Barometric Pressure Sensor

GENERAL DESCRIPTION

The 7-Axis ICM-20789 is an integrated 6-axis inertial device that combines a 3-axis gyroscope, 3-axis accelerometer, and an ultra-low noise MEMS capacitive pressure sensor in a 24-pin LGA package. This unique 7-Axis device offers performance of discrete components in a single small footprint for tracking rotational and linear motion as well as pressure differences with an accuracy of ± 1 Pa, an accuracy enabling altitude measurement differentials as small as 8.5 cm.

The pressure sensor's MEMS capacitive architecture provides the industry's lowest noise at the lowest power, high sensor throughput, and temperature coefficient offset of ± 0.5 Pa/ $^{\circ}$ C. The pressure sensor's combination of high accuracy elevation measurements, low power, and temperature stability complemented by the motion tracking 6-axis inertial sensor in a small footprint, make it ideal for a wide range of motion tracking applications.

The embedded 6-axis MotionTracking device combines a 3-axis gyroscope, 3-axis accelerometer, and a Digital Motion Processor™ (DMP). An available large 4 kB FIFO reduces traffic on the serial bus interface, and power consumption through burst sensor data transmission. The Gyroscope has programmable FSR of ± 250 dps, ± 500 dps, ± 1000 dps and ± 2000 dps. The Accelerometer FSR is programmable to $\pm 2g$, $\pm 4g$, $\pm 8g$ and $\pm 16g$.

ICM-20789 has 16-bit ADC for the 6-axis inertial sensor and 24-bit ADC for the pressure sensor, programmable digital filters, two temperature sensors – one each in 6-axis inertial and pressure sensor. The device features an operating voltage of 1.8V. Communication port includes I²C at 400 kHz (6-axis and Pressure) and 8 MHz SPI (6-axis only). The package is 4x4x1.365 mm 24-pin to minimize board area requirements.

BLOCK DIAGRAM

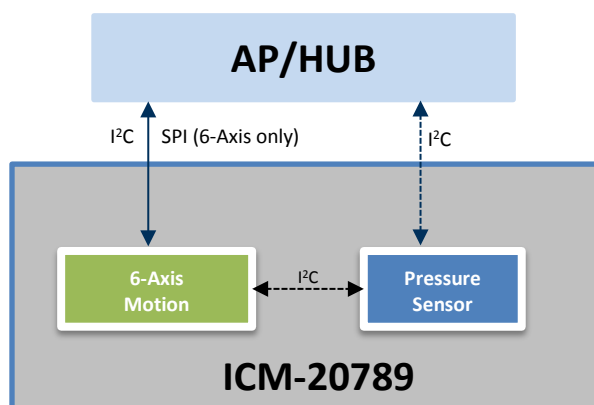

APPLICATIONS

- Drones and Flying Toys
- Motion-based gaming controllers
- Virtual Reality headsets and controllers
- Indoor/Outdoor Navigation (dead-reckoning, floor/elevator/step detection)

FEATURES

- Pressure operating range: 30 to 110 kPa
- Noise and current consumption
 - 3.2 Pa @ 1.3 μ A (LP mode)
 - 0.8 Pa @ 5.2 μ A (LN mode)
 - 0.4 Pa @ 10.4 μ A (ULN mode)
- Pressure Sensor Relative Accuracy: ± 1 Pa for any 10 hPa change over 950 hPa-1050 hPa at 25 $^{\circ}$ C
- Pressure Sensor Absolute Accuracy: ± 1 hPa over 950 hPa-1050 hPa, 0 $^{\circ}$ C to 65 $^{\circ}$ C
- Pressure Sensor Temperature Coefficient Offset: ± 0.5 Pa/ $^{\circ}$ C over 25 $^{\circ}$ C to 45 $^{\circ}$ C at 100 kPa
- Gyroscope programmable FSR of ± 250 dps, ± 500 dps, ± 1000 dps, and ± 2000 dps
- Accelerometer with Programmable FSR of $\pm 2g$, $\pm 4g$, $\pm 8g$, and $\pm 16g$
- Large 4 kB FIFO reduces traffic on the serial bus interface
- EIS FSYNC support
- User-programmable interrupts
- Wake-on-motion interrupt for low power operation of applications processor
- Host interface: 400 kHz Fast Mode I²C & 8 MHz SPI (see datasheet for ICM-20689)
- Digital-output temperature sensor (x2)
- Nominal VDD operation at 1.8V
- RoHS and Green compliant

ORDERING INFORMATION

PART	TEMP RANGE	PACKAGE
ICM-20789†	-40 $^{\circ}$ C to +85 $^{\circ}$ C	24-Pin LGA

† Denotes RoHS and Green-Compliant Package

TABLE OF CONTENTS

General Description 1

Block Diagram 1

Applications 1

Features 1

Ordering Information..... 1

1 Introduction 7

 1.1 Purpose and Scope..... 7

 1.2 Product Overview..... 7

 1.3 Applications..... 7

2 Features 8

 2.1 Gyroscope Features 8

 2.2 Accelerometer Features..... 8

 2.3 Pressure sensor Features 8

 2.4 Additional Features 8

 2.5 Motion Processing 8

3 Electrical Characteristics 9

 3.1 Gyroscope Specifications 9

 3.2 Accelerometer Specifications..... 10

 3.3 Pressure Sensor Specifications..... 11

 3.4 Electrical Specifications..... 12

 3.5 I²C Timing Characterization..... 14

 3.6 Absolute Maximum Ratings 16

4 Applications Information 17

 4.1 Pin Out Diagram and Signal Description 17

 4.2 Typical Operating Circuit..... 18

 4.3 Bill of Materials for External Components 21

 4.4 Block Diagram 22

 4.5 Overview 23

 4.6 Three-Axis MEMS Gyroscope with 16-bit ADCs and Signal Conditioning 24

 4.7 Three-Axis MEMS Accelerometer with 16-bit ADCs and Signal Conditioning..... 24

 4.8 Digital Motion Processor..... 24

 4.9 Pressure Sensor..... 24

 4.10 I²C Serial Communications Interface 24

 4.11 Self-Test..... 25

 4.12 Clocking..... 26

 4.13 Sensor Data Registers 26

 4.14 FIFO..... 26

 4.15 Interrupts..... 26

 4.16 Digital-Output Temperature Sensor 26

4.17	Bias and LDOs	26
4.18	Charge Pump	26
4.19	Standard Power Modes – Update the power modes	27
5	Programmable Interrupts	28
5.1	Per Axis Wake-on-Motion Interrupt	28
6	Digital Interface	29
6.1	I ² C Serial Interface.....	29
6.2	I ² C Interface.....	29
6.3	I ² C Communications Protocol (6-Axis only. For pressure please see chapter 10).....	29
6.4	I ² C Terms	31
7	Serial Interface Considerations.....	33
7.1	ICM-20789 Supported Interfaces	33
8	Register Map.....	34
9	Register Descriptions	36
9.1	Registers Descriptions.....	36
9.2	Registers 0 to 2 – Self-Test Registers	36
9.3	Registers 13 to 15.....	36
9.4	Register 19 – Gyro Offset Adjustment Register	36
9.5	Register 20 – Gyro Offset Adjustment Register	36
9.6	Register 21 – Gyro Offset Adjustment Register	37
9.7	Register 22 – Gyro Offset Adjustment Register	37
9.8	Register 23 – Gyro Offset Adjustment Register	37
9.9	Register 24 – Gyro Offset Adjustment Register	37
9.10	Register 25 – Sample Rate Divider.....	37
9.11	Register 26 – Configuration	38
9.12	Register 27 – Gyroscope Configuration	38
9.13	Register 28 – Accelerometer Configuration	39
9.14	Register 29 – Accelerometer Configuration 2.....	39
9.15	Register 30 – Low Power Mode Configuration	40
9.16	Register 32 – Wake on Motion Threshold	41
9.17	Register 33 – Wake on Motion Threshold	41
9.18	Register 34 – Wake on Motion Threshold	41
9.19	Register 35 – FIFO Enable	42
9.20	Register 55 – Interrupt/Bypass Pin Configuration	42
9.21	Register 56 – Interrupt Enable.....	43
9.22	Register 57 – DMP Interrupt Status.....	43
9.23	Register 58 – Interrupt Status.....	43
9.24	Register 59 – Accelerometer Measurements	43
9.25	Register 60 – Accelerometer Measurements	43
9.26	Register 61 – Accelerometer Measurements	44

9.27	Register 62 – Accelerometer Measurements	44
9.28	Register 63 – Accelerometer Measurements	44
9.29	Register 64 – Accelerometer Measurements	44
9.30	Register 65 – Temperature Measurement	44
9.31	Register 66 – Temperature Measurement	44
9.32	Register 67 – Gyroscope Measurement	44
9.33	Register 68 – Gyroscope Measurement	45
9.34	Register 69 – Gyroscope Measurement	45
9.35	Register 70 – Gyroscope Measurement	45
9.36	Register 71 – Gyroscope Measurement	45
9.37	Register 72 – Gyroscope Measurement	45
9.38	Register 104 – Signal Path Reset.....	45
9.39	Register 105 – Accelerometer Intelligence Control.....	46
9.40	Register 106 – User Control.....	46
9.41	Register 107 – Power Management 1	47
9.42	Register 108 – Power Management 2	47
9.43	Register 114 – FIFO Count Registers.....	47
9.44	Register 115 – FIFO Count Registers.....	48
9.45	Register 116 – FIFO Read Write	48
9.46	Register 117 – Who Am I	48
9.47	Register 119 – Accelerometer Offset Register.....	48
9.48	Register 120 – Accelerometer Offset Register.....	49
9.49	Register 122 – Accelerometer Offset Register.....	49
9.50	Register 123 – Accelerometer Offset Register.....	49
9.51	Register 125 – Accelerometer Offset Register.....	49
9.52	Register 126 – Accelerometer Offset Register.....	49
10	Pressure sensor – How to Read	50
10.1	I ² C Operation And Communication	50
11	Assembly.....	55
11.1	Orientation of Axes.....	55
11.2	Implementation and usage recommendations	55
11.3	Package Dimensions	56
12	Part Number Package Marking	58
13	Ordering Guide	59
14	Reference.....	60
15	Revision History	61

LIST OF FIGURES

Figure 1. I²C Bus Timing Diagram 15

Figure 2. Pin out Diagram for ICM-20789 17

Figure 3. I²C Communication – 1.8V Supply Schematic 18

Figure 4. I²C Communication MCU Interface at 3V or 1.8V Schematic..... 19

Figure 5. SPI Communication for Gyro/Accel; I²C for Pressure Schematic 20

Figure 6. SPI Communication for Gyro/Accel; I²C Pressure; MCU Digital Interface: 1.8V Schematic 20

Figure 7. SPI Communication for Gyro/Accel; I²C for Pressure; MCU Digital Interface: 3.0V Schematic..... 21

Figure 8. ICM-20789 Block Diagram (I²C interface)..... 22

Figure 9. ICM-20789 Block Diagram (SPI/ I²C interface) 23

Figure 10. ICM-20789 Solution Using I²C Interface 25

Figure 11. START and STOP Conditions 29

Figure 12. Acknowledge on the I²C Bus 30

Figure 13. Complete I²C Data Transfer..... 30

Figure 14. I/O Levels and Connections..... 33

Figure 15. Communication Sequence for starting a measurement and reading measurement results..... 54

Figure 16. Orientation of Axes of Sensitivity and Polarity of Rotation 55

Figure 17. Package Dimensions..... 56

Figure 18. ICM-20789 recommended PCB land pattern 57

Figure 19. Part Number Package Marking 58

LIST OF TABLES

Table 1. Gyroscope Specifications9

Table 2. Accelerometer Specifications.....10

Table 3. Operation Ranges.....11

Table 4. Operation Modes11

Table 5. Pressure Sensor Specifications.....11

Table 6. Temperature Sensor Specifications.....12

Table 7. D.C. Electrical Characteristics12

Table 8. A.C. Electrical Characteristics (6-Axis)13

Table 9. Electrical Characteristics (Pressure sensor).....14

Table 10. Other Electrical Specifications.....14

Table 11. I²C Timing Characteristics.....15

Table 12. Absolute Maximum Ratings (6-Axis)16

Table 13. Absolute Maximum Ratings (pressure sensor).....16

Table 14. Signal Descriptions17

Table 15. Bill of Materials21

Table 16. Standard Power Modes for ICM-20789.....27

Table 17. Table of Interrupt Sources.....28

Table 18. Serial Interface29

Table 19. I²C Term SPI Interface.....31

Table 20. Register Map35

Table 21. Accelerometer Data Rates and Bandwidths (Low Noise Mode)39

Table 22. Accelerometer Data Rates and Bandwidths (Low-Power Mode).....40

Table 23. ICM-20789 I²C Device Address50

Table 24. Measurement Commands.....50

Table 25. Soft Reset Command.....51

Table 26. Read-Out Command of ID Register51

Table 27. Structure of the 16-bit ID51

Table 28. ICM-20789 I²C CRC Properties.....51

Table 29. Package Dimensions Table56

1 INTRODUCTION

1.1 PURPOSE AND SCOPE

This document is a product specification, providing a description, specifications, and design related information on the ICM-20789, a 6-axis inertial and pressure sensor device. The device is packaged in a 4 mm x 4 mm x 1.365 mm 24-pin LGA package.

1.2 PRODUCT OVERVIEW

The ICM-20789 is a 6-axis inertial sensor, 3-axis gyroscope and a 3-axis accelerometer, ultra-low noise MEMS capacitive barometric pressure sensor in a 4 mm x 4 mm x 1.365 mm (24-pin LGA) package. It features a 4 KB FIFO that can lower the traffic on the serial bus interface.

The digital output barometric pressure sensor is based on an ultra-low noise innovative MEMS capacitive technology that can measure pressure differences with an accuracy of ± 1 Pa, an accuracy enabling altitude measurement differentials as small as 8.5 cm without the penalty of increased power consumption or reduced sensor throughput. The capacitive pressure sensor has a ± 1 hPa absolute accuracy over its full range of 300 hPa -1100 hPa. The pressure sensor offers industry leading temperature stability of the pressure sensor with a temperature coefficient offset of ± 0.5 Pa/ $^{\circ}$ C, embedded temperature sensor and 400 kHz I²C bus for communication.

The gyroscope has a programmable full-scale range of ± 250 dps, ± 500 dps, ± 1000 dps, and ± 2000 dps. The accelerometer has a user-programmable full-scale range of $\pm 2g$, $\pm 4g$, $\pm 8g$, and $\pm 16g$. Factory-calibrated initial sensitivity of both sensors reduces production-line calibration requirements. Other features include on-chip 16-bit ADCs, programmable digital filters, another embedded temperature sensor, and programmable interrupts. The device features I²C serial interface to access its registers at 400 kHz as well as at 8 MHz SPI.

By leveraging its patented and volume-proven CMOS-MEMS fabrication platform, which integrates MEMS wafers with companion CMOS electronics through wafer-level bonding, TDK has driven the package size down to a footprint and thickness of 4 mm x 4 mm x 1.365 mm (24-pin LGA), to provide an integrated high-performance package. The device provides high robustness by supporting 10,000g shock reliability.

1.3 APPLICATIONS

- Drones and Flying Toys
- Motion-based gaming controllers
- Virtual Reality Headsets & Controllers
- Indoor/Outdoor Navigation (dead-reckoning, floor/elevation/step detection)

2 FEATURES

2.1 GYROSCOPE FEATURES

- Digital-output X-, Y-, and Z-axis angular rate sensors (gyroscopes) with a user-programmable full-scale range of ± 250 dps, ± 500 dps, ± 1000 dps, and ± 2000 dps and integrated 16-bit ADCs
- Digitally-programmable low-pass filter
- Low-power gyroscope operation
- Factory calibrated sensitivity scale factor
- Self-test

2.2 ACCELEROMETER FEATURES

- Digital-output X-, Y-, and Z-axis accelerometer with a programmable full scale range of $\pm 2g$, $\pm 4g$, $\pm 8g$, and $\pm 16g$ and integrated 16-bit ADCs
- User-programmable interrupts
- Wake-on-motion interrupt for low power operation of applications processor
- Self-test

2.3 PRESSURE SENSOR FEATURES

- Pressure operating range: 30 kPa to 110 kPa
- 4 operating modes to optimize noise and power, 3 example modes:
 - 3.2 Pa @ 1.3 μ A (LP mode)
 - 0.8 Pa @ 5.2 μ A (LN mode)
 - 0.4 Pa @ 10.4 μ A (ULN mode)
- Relative accuracy: ± 1 Pa for any 10 hPa change over 950 hPa-1050 hPa at 25°C
- Absolute accuracy: ± 1 hPa over 950 hPa-1050 hPa, 0°C to 65°C
- Temperature Coefficient Offset: ± 0.5 Pa/°C over 25°C to 45°C at 100 kPa
- I²C at 400 kHz
- Temperature sensor accuracy: ± 0.4 °C

2.4 ADDITIONAL FEATURES

- Minimal cross-axis sensitivity between the accelerometer and gyroscope axes
- 4 kB FIFO buffer enables the applications processor to read the data in bursts
- Digital-output temperature sensor
- User-programmable digital filters for gyroscope, accelerometer, and temp sensor
- 10,000g shock tolerant
- 400 kHz Fast Mode I²C for communicating with all registers
- RoHS and Green compliant

2.5 MOTION PROCESSING

- Internal Digital Motion Processing™ (DMP™) engine supports advanced MotionProcessing and low power functions
- DMP operation is possible in low-power gyroscope and low-power accelerometer modes

3 ELECTRICAL CHARACTERISTICS

3.1 GYROSCOPE SPECIFICATIONS

Typical Operating Circuit Figure 3, VDD = 1.8V, VDDIO = 1.8V, T_A=25°C, unless otherwise noted.

PARAMETER	CONDITIONS	MIN	TYP	MAX	UNITS	NOTES
GYROSCOPE SENSITIVITY						
Full-Scale Range	FS_SEL=0		±250		dps	3
	FS_SEL=1		±500		dps	3
	FS_SEL=2		±1000		dps	3
	FS_SEL=3		±2000		dps	3
Gyroscope ADC Word Length			16		bits	3
Sensitivity Scale Factor	FS_SEL=0		131		LSB/(dps)	3
	FS_SEL=1		65.5		LSB/(dps)	3
	FS_SEL=2		32.8		LSB/(dps)	3
	FS_SEL=3		16.4		LSB/(dps)	3
Sensitivity Scale Factor Tolerance	Component-Level, 25°C		±2		%	2
Sensitivity Scale Factor Variation Over Temperature	-40°C to +85°C		±1.5		%	1
Nonlinearity	Best fit straight line; 25°C		±0.1		%	1
Cross-Axis Sensitivity			±2		%	1
ZERO-RATE OUTPUT (ZRO)						
Initial ZRO Tolerance	Component-Level, 25°C		±5		dps	2
ZRO Variation Over Temperature	-40°C to +85°C		±0.05		dps/°C	1
GYROSCOPE NOISE PERFORMANCE (FS_SEL=0)						
Noise Spectral Density			0.006		dps/√Hz	1
Gyroscope Mechanical Frequencies		25	27	29	kHz	2
Low Pass Filter Response	Programmable Range	5		250	Hz	3
Gyroscope Start-Up Time	From Sleep mode		35		ms	1
Output Data Rate	Standard (duty-cycled) mode	3.91		500	Hz	1
	Low-Noise (active) mode	4		8000	Hz	1

Table 1. Gyroscope Specifications

Notes:

1. Derived from validation or characterization of parts, not guaranteed in production.
2. Tested in production.
3. Guaranteed by design.

3.2 ACCELEROMETER SPECIFICATIONS

Typical Operating Circuit Figure 3, VDD = 1.8V, VDDIO = 1.8V, T_A=25°C, unless otherwise noted.

PARAMETER	CONDITIONS	MIN	TYP	MAX	UNITS	NOTES
ACCELEROMETER SENSITIVITY						
Full-Scale Range	AFS_SEL=0		±2		<i>g</i>	3
	AFS_SEL=1		±4		<i>g</i>	3
	AFS_SEL=2		±8		<i>g</i>	3
	AFS_SEL=3		±16		<i>g</i>	3
ADC Word Length	Output in two's complement format		16		bits	3
Sensitivity Scale Factor	AFS_SEL=0		16,384		LSB/ <i>g</i>	3
	AFS_SEL=1		8,192		LSB/ <i>g</i>	3
	AFS_SEL=2		4,096		LSB/ <i>g</i>	3
	AFS_SEL=3		2,048		LSB/ <i>g</i>	3
Sensitivity Initial Tolerance	Component-Level, 25°C		±2		%	2
Sensitivity Change vs. Temperature	-40°C to +85°C		±1		%	1
Nonlinearity	Best Fit Straight Line		±0.5		%	1
Cross-Axis Sensitivity			±2		%	1
ZERO-G OUTPUT						
Offset Initial Tolerance	Component-Level, 25°C		±80		<i>mg</i>	2
Zero-G Level Change vs. Temperature	-5°C to +85°C		±0.75		<i>mg</i> /°C	1
NOISE PERFORMANCE						
Noise Spectral Density			150		μ <i>g</i> /√Hz	1
Low Pass Filter Response	Programmable Range	5		218	Hz	3
Intelligence Function Increment			4		<i>mg</i> /LSB	3
Accelerometer Startup Time	From Sleep mode		20		ms	1
	From Cold Start, 1 ms V _{DD} ramp		30		ms	1
Output Data Rate	Standard (duty-cycled) mode	0.24		500	Hz	1
	Low-Noise (active) mode	4		4000	Hz	

Table 2. Accelerometer Specifications

Notes:

1. Derived from validation or characterization of parts, not guaranteed in production.
2. Tested in production.
3. Guaranteed by design.

3.3 PRESSURE SENSOR SPECIFICATIONS

Typical Operating Circuit Figure 3, VDD = 1.8V, VDDIO = 1.8V, TA=25°C, unless otherwise noted.

OPERATION RANGE	PRESSURE (kPa)	TEMPERATURE (°C)
Normal	70 to 110	0 to 65
Extended	30 to 110	0 to 65
Maximum	25 to 115	-40 to 85

Table 3. Operation Ranges

PRESSURE PARAMETER	CONDITIONS	Sensor Mode	TYP	MAX	UNITS	NOTES
Conversion Time	Time between sending last bit of measurement command, and sensor data ready for measurement	Low Power (LP)	1.6	1.8	ms	1
		Normal (N)	5.6	6.3		1
		Low Noise (LN)	20.8	23.8		1
		Ultra Low Noise (ULN)	83.2	94.5		1
Current Consumption	1 Hz ODR	Low Power (LP)	1.3		µA	
		Normal (N)	2.6			
		Low Noise (LN)	5.2			
		Ultra Low Noise (ULN)	10.4			
Pressure RMS Noise	Valid for P = 100 kPa, T = 25°C, and U = 1.8V	Low Power (LP)	3.2		Pa	
		Normal	1.6			
		Low Noise (LN)	0.8			
		Ultra Low Noise (ULN)	0.4			

Table 4. Operation Modes

Notes:

1. Guaranteed by design.

PARAMETER	CONDITIONS	TYP	UNITS	NOTES
Absolute Accuracy	Normal range	±1	hPa	1
	Extended range	±1.5		
Relative Accuracy	Any step ≤ 1 kPa, 25 °C	±1	Pa	
	Any step ≤ 10 kPa, 25 °C	±3		
Long-term drift During 1 year	Extended range	±1	hPa/y	
Solder drift		1.5	hPa	1, 2
Temperature coefficient offset	P = 100 kPa 25°C ... 45°C	±0.5	Pa/°C	
Resolution	Maximum range	0.01	Pa	

Table 5. Pressure Sensor Specifications

Notes:

1. Absolute accuracy may be improved through One Point Calibration
2. Sensor accuracy post Solder reflow may be improved through One Point Calibration

Temperature PARAMETER	CONDITIONS	TYP	MAX	UNITS	NOTES
Absolute Accuracy	Extended range	±0.4		°C	
Repeatability	Extended range	±0.1		°C	
Resolution	Maximum range	0.01		°C	
Long-term drift	Normal range	<0.04		°C/y	

Table 6. Temperature Sensor Specifications

3.4 ELECTRICAL SPECIFICATIONS

D.C. Electrical Characteristics

Typical Operating Circuit Figure 3, VDD = 1.8V, VDDIO = 1.8V, T_A=25°C, unless otherwise noted.

PARAMETER	CONDITIONS	MIN	TYP	MAX	UNITS	NOTES
SUPPLY VOLTAGES						
VDD (For 6-axis MEMS)		1.71	1.8	3.45	V	1
VDDIO (Pressure Sensor VDD and Chip I/O)		1.71	1.8	1.98	V	1
SUPPLY CURRENTS & BOOT TIME						
Normal Mode	7-axis Gyroscope + Accelerometer + Pressure		3.0		mA	1
	3-axis Gyroscope		2.6		mA	1
	3-axis Accelerometer, 4 kHz ODR		390		μA	1
	Pressure Sensor		1.1		μA	1
Accelerometer Low -Power Mode	100 Hz ODR, 1x averaging		57		μA	2
Gyroscope Low-Power Mode	100 Hz ODR, 1x averaging		1.6		mA	2
6-Axis Low-Power Mode (Gyroscope Low-Power Mode; Accelerometer Low-Noise Mode)	100 Hz ODR, 1x averaging		1.9		mA	2
Full-Chip Sleep Mode			6		μA	1
TEMPERATURE RANGE						
Specified Temperature Range	Performance parameters are not applicable beyond Specified Temperature Range	-40		+85	°C	1

Table 7. D.C. Electrical Characteristics
Notes:

1. Derived from validation or characterization of parts, not guaranteed in production.
2. Based on simulation.

A.C. Electrical Characteristics

Typical Operating Circuit Figure 3, VDD = 1.8V, VDDIO = 1.8V, TA=25°C, unless otherwise noted.

PARAMETER	CONDITIONS	MIN	TYP	MAX	UNITS	NOTES
SUPPLIES						
Supply Ramp Time (T _{RAMP})	Monotonic ramp. Ramp rate is 10% to 90% of the final value	0.01		100	ms	1
TEMPERATURE SENSOR						
Operating Range	Ambient	-40		85	°C	1
Room Temperature Offset	25°C		0		°C	1
Sensitivity	Untrimmed		0.003		°C/LSB	1
POWER-ON RESET						
Supply Ramp Time (T _{RAMP}) (6-Axis)	Valid power-on RESET	0.01		100	ms	1
Start-up time for register read/write (6-Axis)	From power-up		11	100	ms	1
	From sleep			5	ms	1
Power-up time (pressure sensor)	After hard reset (V _{DD} >V _{por})		170		μs	1
Soft reset time (Pressure sensor)	After soft reset		170		μs	a
I²C ADDRESS	AD0 = 0		1101000			
	AD0 = 1		1101001			
DIGITAL INPUTS (FSYNC, AD0)						
V _{IH} , High-Level Input Voltage		0.7*VDDIO			V	1
V _{IL} , Low-Level Input Voltage				0.3*VDDIO	V	
C _i , Input Capacitance			< 10		pF	
DIGITAL OUTPUT (INT)						
V _{OH} , High-Level Output Voltage	R _{LOAD} = 1 MΩ;	0.9*VDDIO			V	1
V _{OL1} , Low-Level Output Voltage	R _{LOAD} = 1 MΩ;			0.1*VDDIO	V	
V _{OL,INT} , INT Low-Level Output Voltage	OPEN = 1, 0.3 mA sink Current			0.1	V	
Output Leakage Current	OPEN = 1		100		nA	
t _{INT} , INT Pulse Width	LATCH_INT_EN = 0		50		μs	
I²C I/O (SCL, SDA)						
V _{IL} , Low-Level Input Voltage		-0.5 V		0.3*VDDIO	V	1
V _{IH} , High-Level Input Voltage		0.7*VDDIO		VDDIO + 0.5 V	V	
V _{hys} , Hysteresis			0.1*VDDIO		V	
V _{OL} , Low-Level Output Voltage	3 mA sink current	0		0.4	V	
I _{OL} , Low-Level Output Current	V _{OL} = 0.4 V		3		mA	
	V _{OL} = 0.6 V		6		mA	
Output Leakage Current			100		nA	
t _{of} , Output Fall Time from V _{IHmax} to V _{ILmax}	C _b bus capacitance in pf	20+0.1C _b		300	ns	

Table 8. A.C. Electrical Characteristics (6-Axis)
Notes:

1. Guaranteed by design

PARAMETER	SYMBOL	CONDITIONS	MIN	TYP	MAX	UNITS	COMMENTS
Supply voltage	V _{DD}		1.71	1.8	1.89	V	
Power-up/down level	V _{POR}	Static power supply	1.0	1.25	1.5	V	
Supply current	I _{DD}	Idle state	-	1.0	2.5	μA	
		Measurement	-	210	300	μA	Current consumption while sensor is measuring.
		Average	-	1.3	-	μA	Current consumption in continuous operation @ 1 Hz ODR in LP Mode
-	5.2		-	μA	Current consumption in continuous operation @1 Hz ODR in LN Mode		
Low level input voltage	V _{IL}		0	-	0.3 V _{DD}	V	
High level input voltage	V _{IH}		0.7 V _{DD}	-	V _{DD}	V	
Low level output voltage	V _{OL}	0 < I _{OL} < 3 mA	-	-	0.2 V _{DD}	V	
Output Sink Current	I _{OL}	V _{OL} = 0.4V	3.1	4.1	-	mA	
		V _{OL} = 0.6V	3.5	4.5	-	mA	

Table 9. Electrical Characteristics (Pressure sensor)

Other Electrical Specifications

Typical Operating Circuit Figure 3, V_{DD} = 1.8V, V_{DDIO} = 1.8V, T_A=25°C, unless otherwise noted.

PARAMETER	CONDITIONS	MIN	TYP	MAX	UNITS	NOTES
SERIAL INTERFACE						
I ² C Operating Frequency	All registers, Fast-mode			400	kHz	1
	All registers, Standard-mode			100	kHz	1

Table 10. Other Electrical Specifications

Notes:

1. Derived from validation or characterization of parts, not guaranteed in production.

3.5 I²C TIMING CHARACTERIZATION

Typical Operating Circuit Figure 3, V_{DD} = 1.8V, V_{DDIO} = 1.8V, T_A=25°C, unless otherwise noted.

PARAMETERS	CONDITIONS	MIN	TYP	MAX	UNITS	NOTES
I²C TIMING						
I²C FAST-MODE						
f _{SCL} , SCL Clock Frequency				400	kHz	1
t _{HD,STA} , (Repeated) START Condition Hold Time		0.6			μs	1
t _{LOW} , SCL Low Period		1.3			μs	1
t _{HIGH} , SCL High Period		0.6			μs	1
t _{SU,STA} , Repeated START Condition Setup Time		0.6			μs	1
t _{HD,DAT} , SDA Data Hold Time		0			μs	1
t _{SU,DAT} , SDA Data Setup Time		100			ns	1
t _r , SDA and SCL Rise Time	C _b bus cap. from 10 to 400 pF	20+0.1C _b		300	ns	1
t _f , SDA and SCL Fall Time	C _b bus cap. from 10 to 400 pF	20+0.1C _b		300	ns	1
t _{SU,STO} , STOP Condition Setup Time		0.6			μs	1
t _{BUF} , Bus Free Time Between STOP and START Condition		1.3			μs	1
C _b , Capacitive Load for each Bus Line			< 400		pF	1

PARAMETERS	CONDITIONS	MIN	TYP	MAX	UNITS	NOTES
I²C TIMING						
$t_{VD.DAT}$, Data Valid Time	I ² C FAST-MODE			0.9	μ s	1
$t_{VD.ACK}$, Data Valid Acknowledge Time				0.9	μ s	1

Table 11. I²C Timing Characteristics

Notes:

- Based on characterization of 5 parts over temperature and voltage as mounted on evaluation board or in sockets

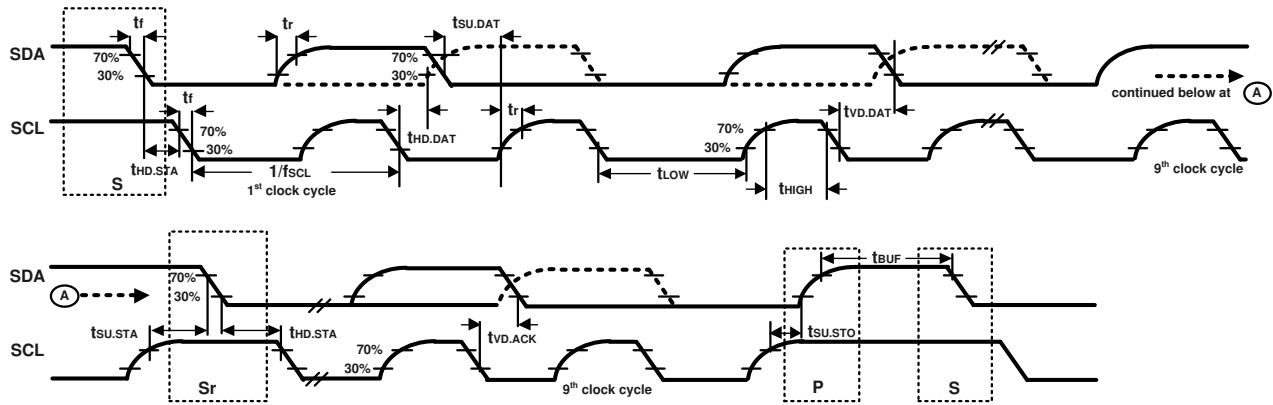

Figure 1. I²C Bus Timing Diagram

3.6 ABSOLUTE MAXIMUM RATINGS

Stress above those listed as “Absolute Maximum Ratings” may cause permanent damage to the device. These are stress ratings only and functional operation of the device at these conditions is not implied. Exposure to the absolute maximum ratings conditions for extended periods may affect device reliability.

PARAMETER	RATING
Supply Voltage, VDD (for 6-axis MEMS)	-0.5V to +4V
Supply Voltage, VDDIO (for Pressure Sensor VDD and I/O)	-0.5V to +2.16V
REGOUT	-0.5V to 2V
Input Voltage Level (AD0, FSYNC, SCL, SDA)	-0.5V to VDD + 0.5V
Acceleration (Any Axis, unpowered)	10,000g for 0.2 ms
Operating Temperature Range	-40°C to +85°C
Storage Temperature Range	-40°C to +125°C
Electrostatic Discharge (ESD) Protection	2 kV (HBM); 250V (MM)
Latch-up	JEDEC Class II (2), 125°C ±100 mA

Table 12. Absolute Maximum Ratings (6-Axis)

PARAMETER	RATING
Supply voltage, VDD	-0.3V to +2.16V
Supply Voltage, SCL & SDA	-0.3V to VDD +0.3V
Operating temperature range	-40°C to +85°C
Storage temperature range	-40°C to +125°C
ESD HBM	1.0 kV
ESD CDM	250V
Latch up, JESD78 Class II, 85°C	100 mA
Overpressure	>600 kPa

Table 13. Absolute Maximum Ratings (pressure sensor)

4 APPLICATIONS INFORMATION

4.1 PIN OUT DIAGRAM AND SIGNAL DESCRIPTION

PIN NUMBER	PIN NAME	PIN DESCRIPTION
6	PR_DA	I ² C interface data pin for Pressure Sensor access
7	PR_CL	I ² C interface clock pin for Pressure Sensor access
8	VDDIO	Digital I/O supply voltage
9	AD0/SDO	I ² C slave address LSB (AD0); SPI serial data output (SDO)
10	REGOUT	Regulator filter capacitor connection
11	FSYNC	Frame synchronization digital input. Connect to GND if unused.
12	INT	Interrupt digital output (totem pole or open-drain)
13	VDD	Power supply voltage
18	GND	Power supply ground
22	nCS	SPI chip select
23	SCL/SCLK	I ² C serial clock (SCL); SPI serial clock (SCLK)
24	SDA/SDI	I ² C serial data (SDA); SPI serial data input (SDI)
1, 19, 20, 21	NC	No Connect
2, 3, 4, 5, 14, 15, 16, 17	GND/VDD/NC	Connect to: GND or VDD or No Connection

Table 14. Signal Descriptions

Note:

1. VDD and VDDIO cannot be shorted if VDD > 1.98V
2. VDD & VDDIO should not violate operating range specifications as mentioned in Section 3.4

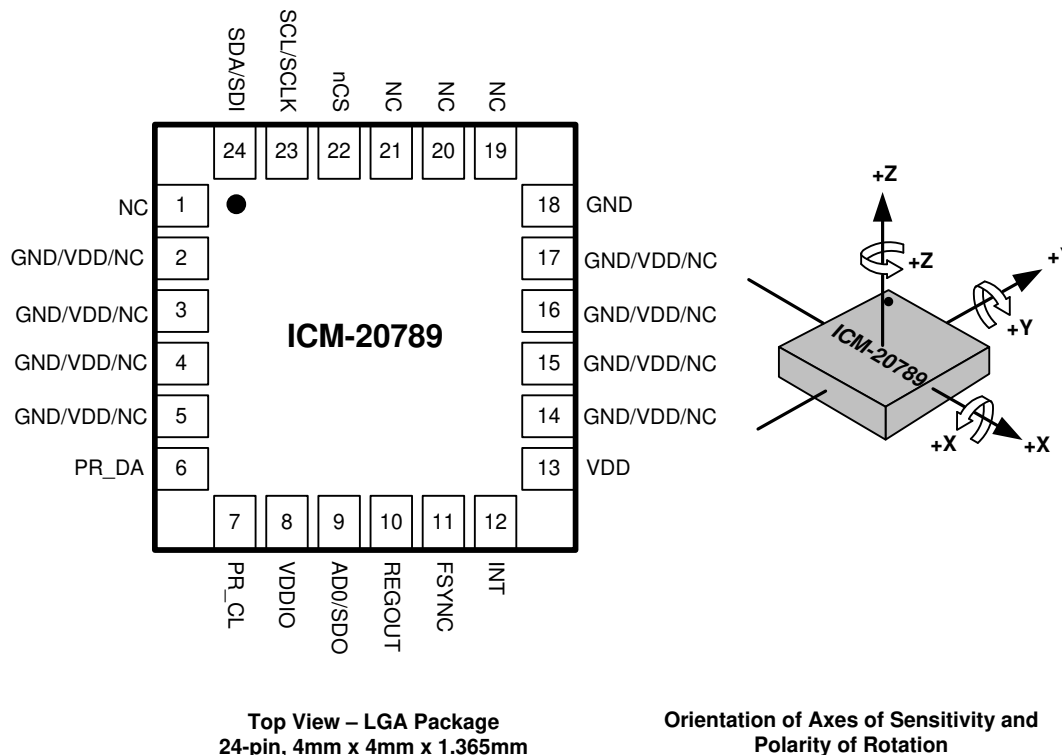
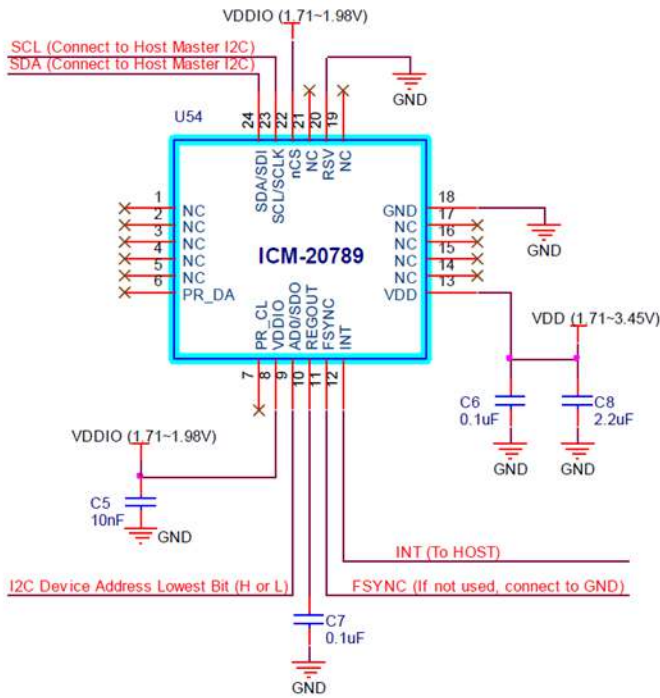

Figure 2. Pin out Diagram for ICM-20789

4.2 TYPICAL OPERATING CIRCUIT

I²C Communication – 1.8V Supply Schematic



I2C device address:

- Gyro/Accel = 0x68 (AD0=L, pin-9)
- Gyro/Accel = 0x69 (AD0=H, pin-9)
- Pressure sensor = 0x63

ICM-20789 Register Setting:

- Bypass = enable
- Master I2C = disable

Figure 3. I²C Communication – 1.8V Supply Schematic

I²C Communication MCU Interface at 3V or 1.8V Schematic

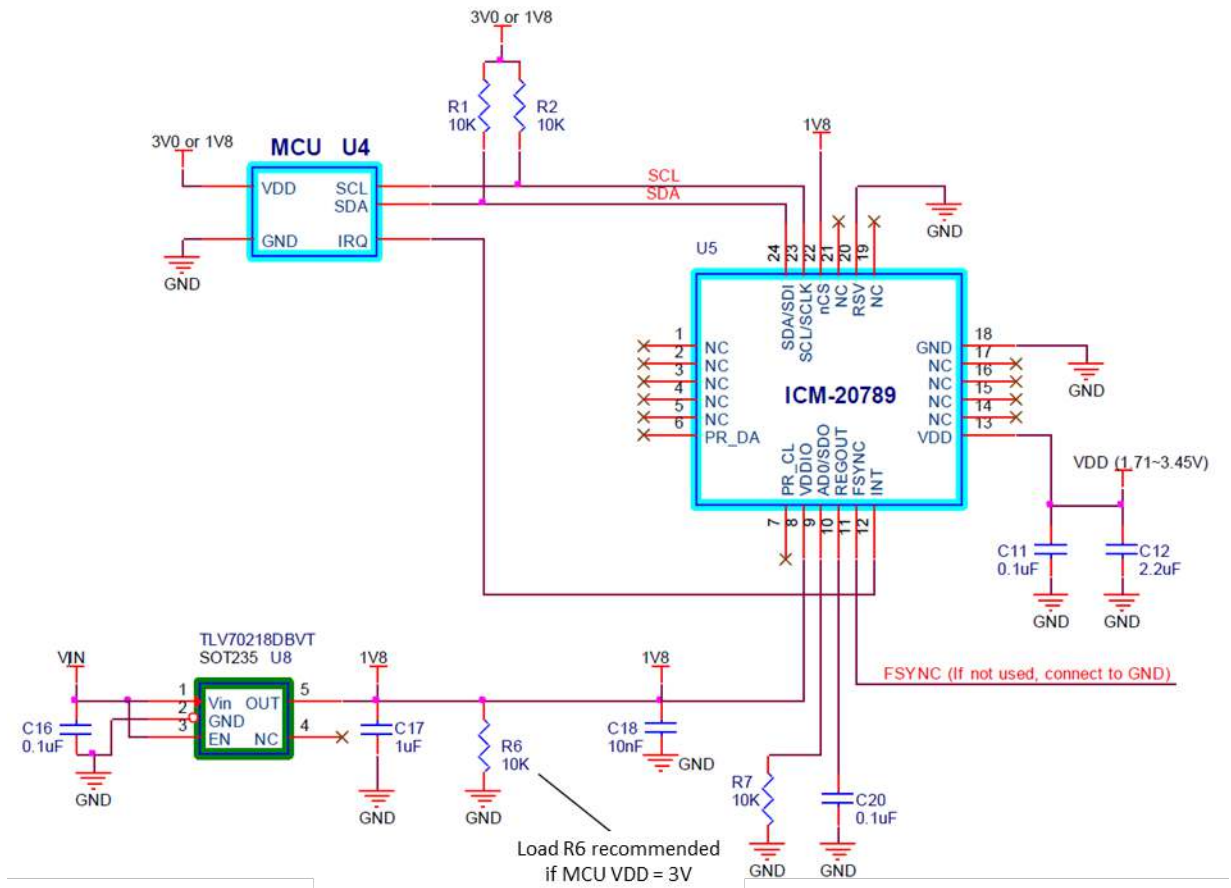

Figure 4. I²C Communication MCU Interface at 3V or 1.8V Schematic

SPI Communication for Gyro/Accel; I²C for Pressure Schematic

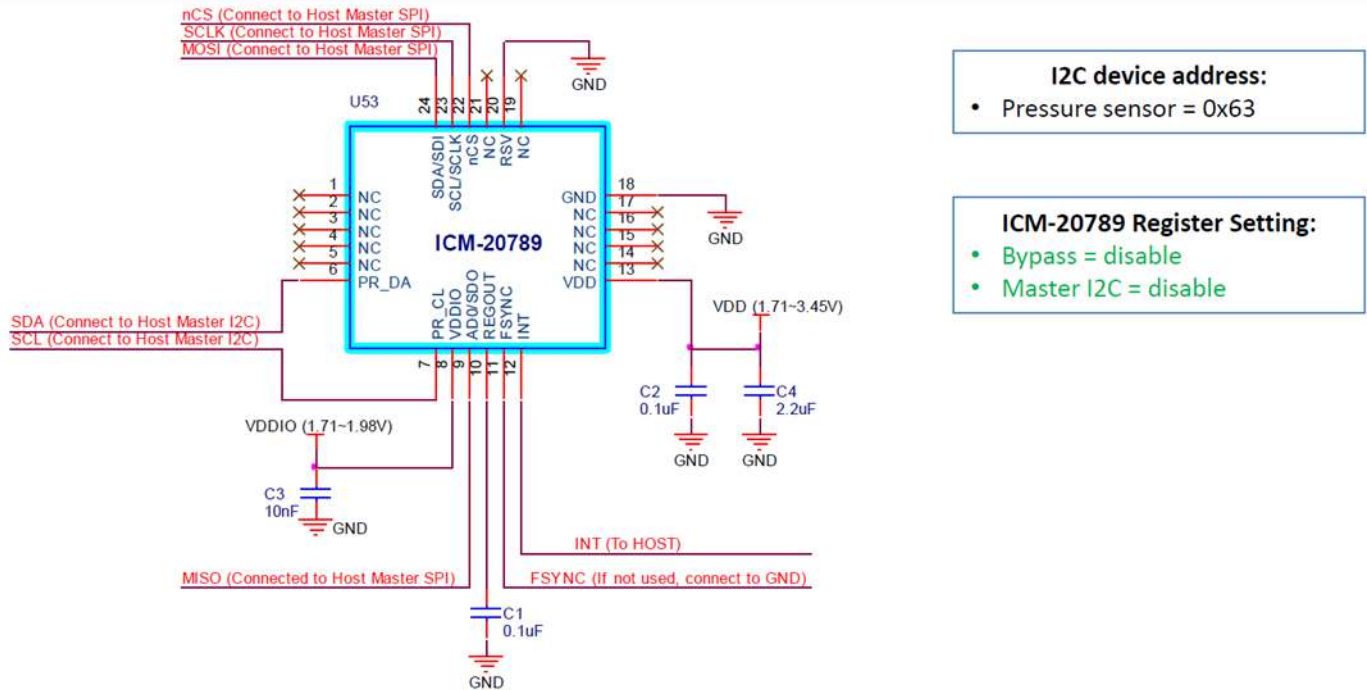

Figure 5. SPI Communication for Gyro/Accel; I²C for Pressure Schematic

SPI Communication for Gyro/Accel; I²C Pressure; MCU Digital Interface: 1.8V Schematic

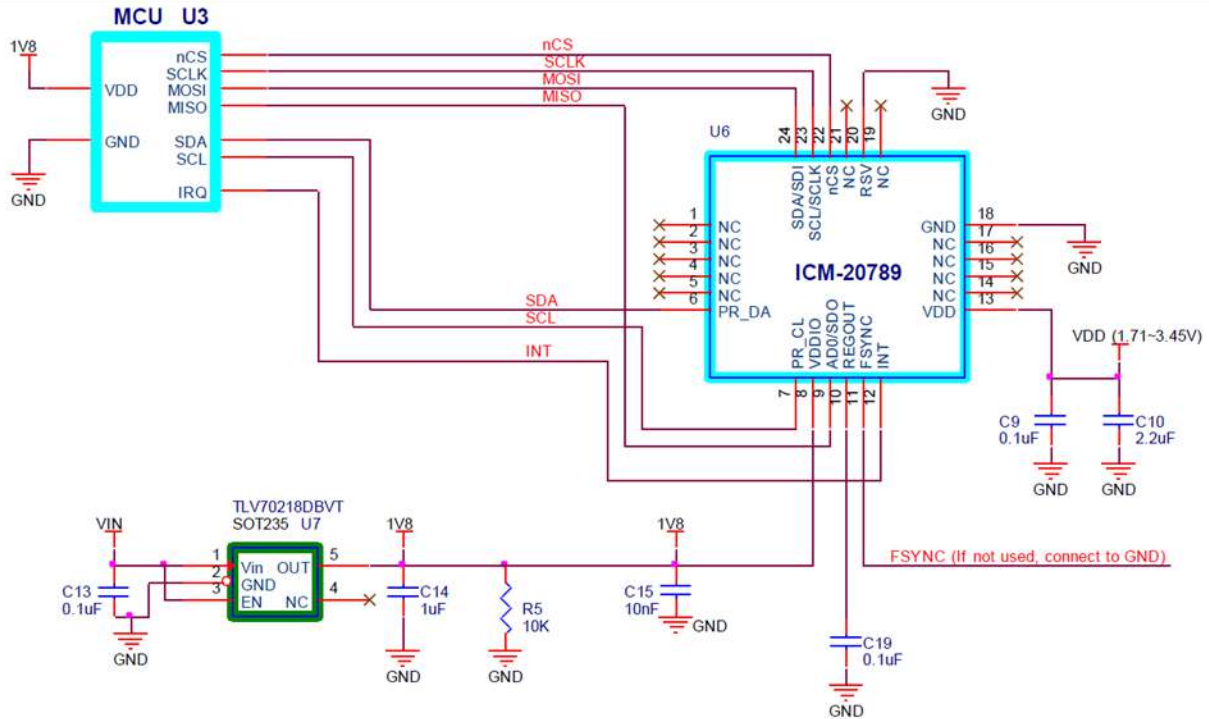

Figure 6. SPI Communication for Gyro/Accel; I²C Pressure; MCU Digital Interface: 1.8V Schematic

SPI Communication for Gyro/Accel; I²C for Pressure; MCU Digital Interface: 3.0V Schematic

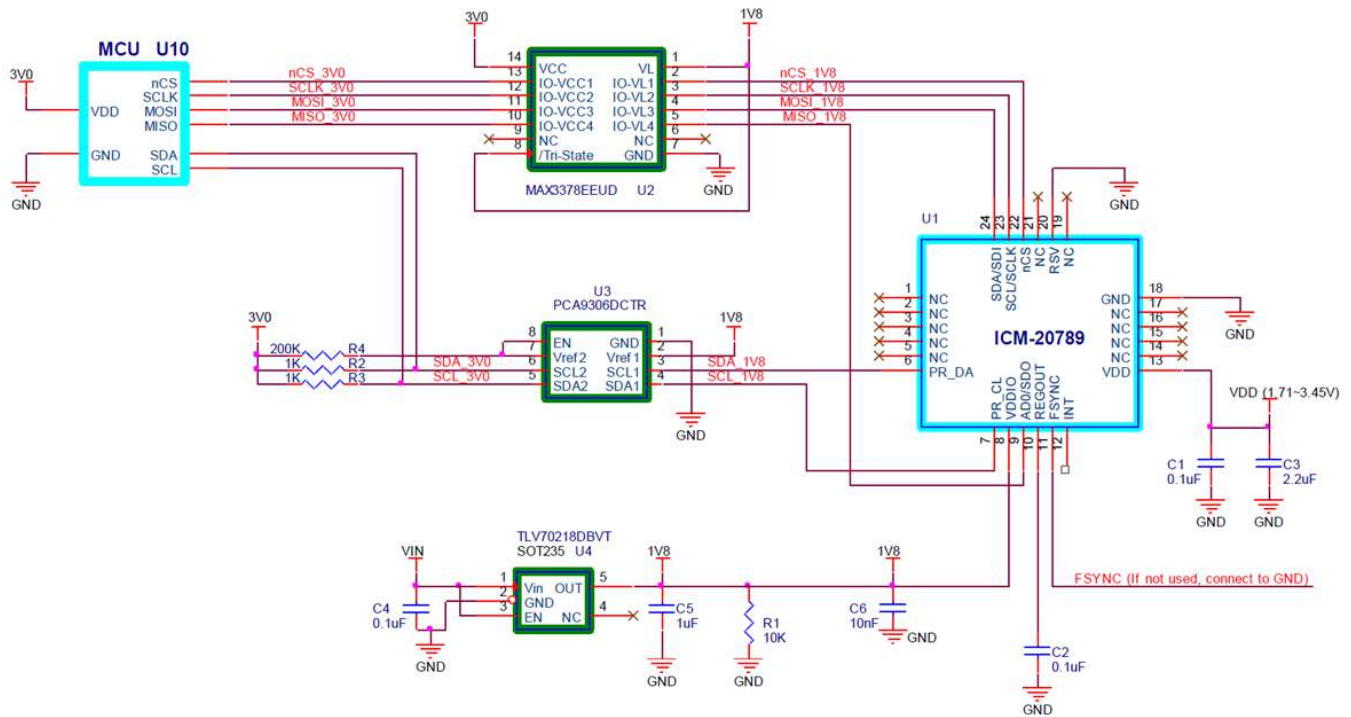

Figure 7. SPI Communication for Gyro/Accel; I²C for Pressure; MCU Digital Interface: 3.0V Schematic

Note: I²C lines are open drain and pullup resistors (e.g. 10 kΩ) are required.

4.3 BILL OF MATERIALS FOR EXTERNAL COMPONENTS

COMPONENT	LABEL	SPECIFICATION	QUANTITY
REGOUT Capacitor	C1	X7R, 0.1 μF ±10%	1
VDD Bypass Capacitors	C2	X7R, 0.1 μF ±10%	1
	C4	X7R, 2.2 μF ±10%	1
VDDIO Bypass Capacitor	C3	X7R, 10 nF ±10%	1

Table 15. Bill of Materials

4.4 BLOCK DIAGRAM

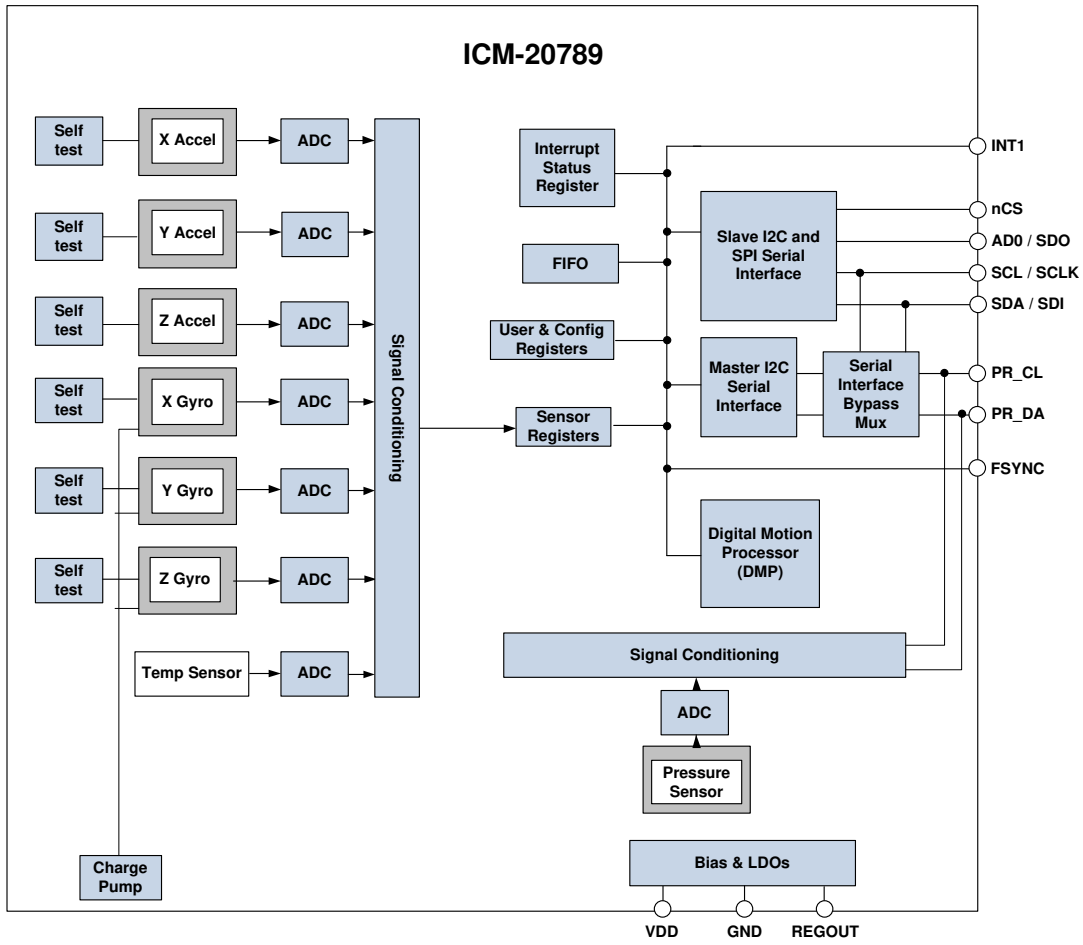

Figure 8. ICM-20789 Block Diagram (I2C interface)

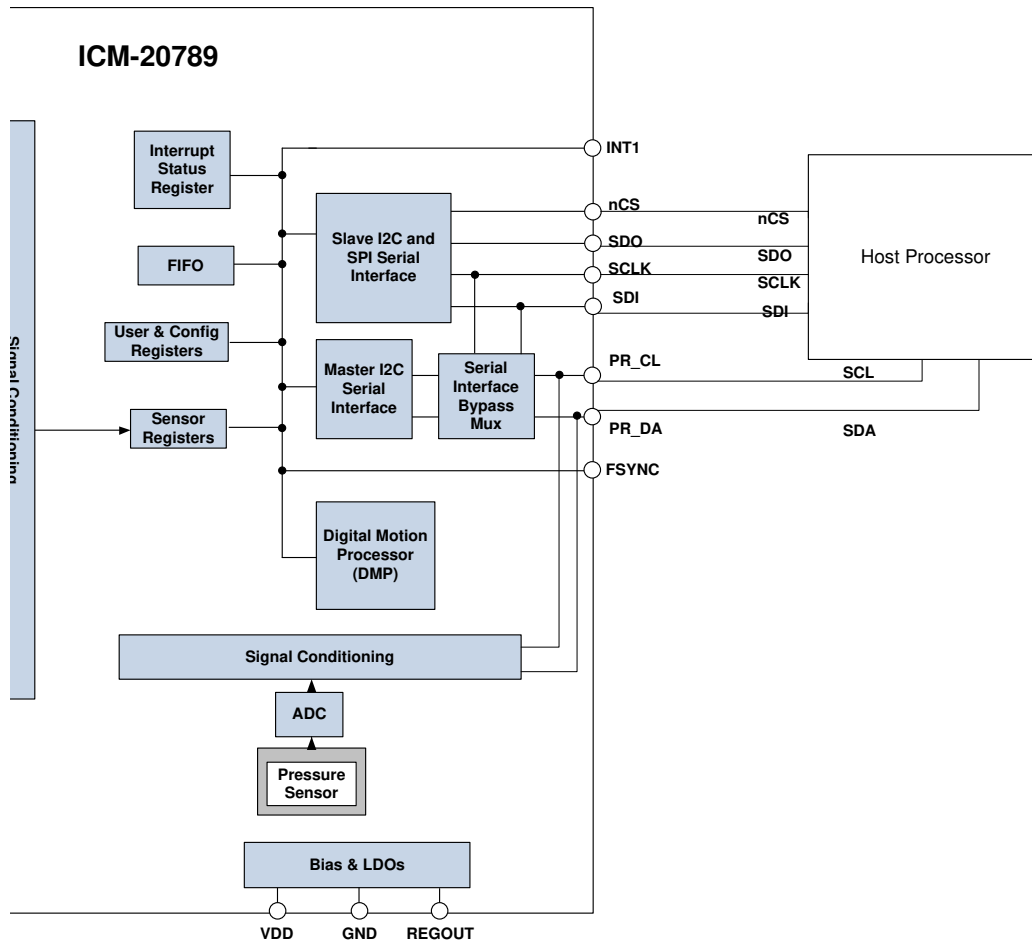

Figure 9. ICM-20789 Block Diagram (SPI/ I²C interface)

4.5 OVERVIEW

The ICM-20789 is comprised of the following key blocks and functions:

- Three-axis MEMS rate gyroscope sensor with 16-bit ADCs and signal conditioning
- Three-axis MEMS accelerometer sensor with 16-bit ADCs and signal conditioning
- Digital Motion Processor (DMP) engine
- I²C serial communications interfaces
- Self-Test
- Clocking
- Sensor Data Registers
- FIFO
- Interrupts
- Digital-Output Temperature Sensor
- Bias and LDOs
- Charge Pump
- Standard Power Modes
- Pressure Sensor

4.6 THREE-AXIS MEMS GYROSCOPE WITH 16-BIT ADCS AND SIGNAL CONDITIONING

The ICM-20789 consists of three independent vibratory MEMS rate gyroscopes, which detect rotation about the X-, Y-, and Z- Axes. When the gyros are rotated about any of the sense axes, the Coriolis Effect causes a vibration that is detected by a capacitive pickoff. The resulting signal is amplified, demodulated, and filtered to produce a voltage that is proportional to the angular rate. This voltage is digitized using individual on-chip 16-bit Analog-to-Digital Converters (ADCs) to sample each axis. The full-scale range of the gyro sensors may be digitally programmed to ± 250 , ± 500 , ± 1000 , or ± 2000 degrees/sec (dps). The ADC sample rate is programmable from 8,000 samples/sec, to 3.9 samples/sec, and user-selectable low-pass filters enable a wide range of cut-off frequencies.

4.7 THREE-AXIS MEMS ACCELEROMETER WITH 16-BIT ADCS AND SIGNAL CONDITIONING

The ICM-20789's 3-Axis accelerometer uses separate proof masses for each axis. Acceleration along a particular axis induces displacement on the corresponding proof mass, and capacitive sensors detect the displacement differentially. The ICM-20789's architecture reduces the accelerometers' susceptibility to fabrication variations as well as to thermal drift. When the device is placed on a flat surface, it will measure $0g$ on the X- and Y-axes and $+1g$ on the Z-axis. The accelerometers' scale factor is calibrated at the factory and is nominally independent of supply voltage. Each sensor has a dedicated sigma-delta ADC for providing digital outputs. The full-scale range of the digital output can be adjusted to $\pm 2g$, $\pm 4g$, $\pm 8g$, or $\pm 16g$.

4.8 DIGITAL MOTION PROCESSOR

The embedded Digital Motion Processor (DMP) offloads computation of motion processing algorithms from the host processor. The DMP acquires data from the accelerometer and gyroscope, processes the data, and the results can be read from the FIFO. The DMP has access to one of the external pins, which can be used for generating interrupts. The purpose of the DMP is to offload both timing requirements and processing power from the host processor. Typically, motion processing algorithms should be run at a high rate, often around 200 Hz, in order to provide accurate results with low latency. This is required even if the application updates at a much lower rate; for example, a low power user interface may update as slowly as 5 Hz, but the motion processing should still run at 200 Hz. The DMP can be used to minimize power, simplify timing, simplify the software architecture, and save valuable MIPS on the host processor for use in applications. DMP operation is possible in low-power gyroscope and low-power accelerometer modes.

4.9 PRESSURE SENSOR

The pressure sensor is a capacitive pressure sensor, and has a membrane over a sealed cavity at a reference pressure. External pressure changes relative to the sealed cavity pressure cause the membrane to deflect. The membrane and the floor of the cavity form a capacitor where the capacitance changes in response to changes in external pressure. The capacitance measurement is converted to a voltage proportional to the external pressure by the on-chip electronics. An external algorithm is used to compensate for temperature effects on the pressure accuracy.

4.10 I²C SERIAL COMMUNICATIONS INTERFACE

The ICM-20789 communicates to a system processor using a I²C serial interface. The ICM-20789 always acts as a slave when communicating to the system processor. The LSB of the I²C slave address is set by pin 9 (AD0).

ICM-20789 Solution Using I²C Interface

Recommended operation mode is described in Figure 5, with the system processor being an I²C master to the ICM-20789.

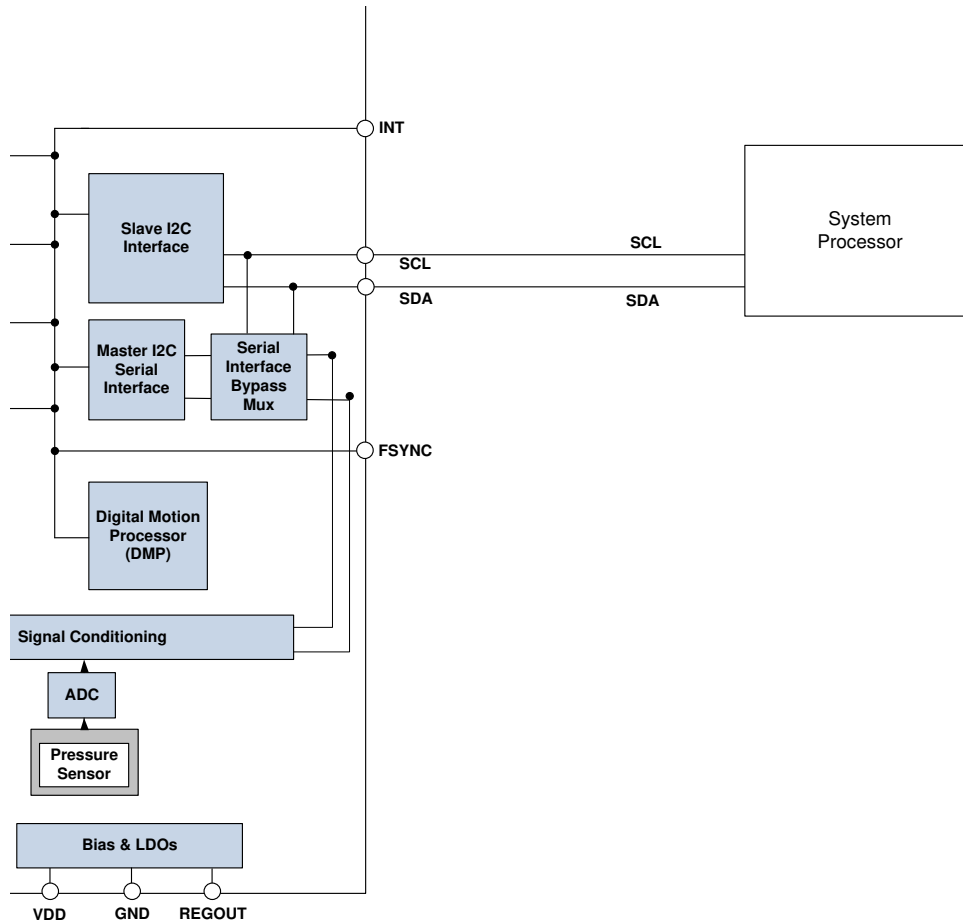

Figure 10. ICM-20789 Solution Using I²C Interface

Note: I²C lines are open drain and pullup resistors (e.g. 10 kΩ) are required.

Accessing Pressure Sensor Data

Pressure sensor data can be accessed in the following mode:

- Bypass Mode: Set register INT_PIN_CFG (Address: 55 (Decimal); 37 (Hex)) bit 1 to value 1 and I2C_MST_EN bit is '0' (Address: 106 (Decimal); 6A (Hex)). Pressure sensor data can then be accessed using the procedure described in Section 10.

4.11 SELF-TEST

Self-test allows for the testing of the mechanical and electrical portions of the sensors. The self-test for each measurement axis can be activated by means of the gyroscope and accelerometer self-test registers (registers 27 and 28).

When the self-test is activated, the electronics cause the sensors to be actuated and produce an output signal. The output signal is used to observe the self-test response.

The self-test response is defined as follows:

$$\text{SELF-TEST RESPONSE} = \text{SENSOR OUTPUT WITH SELF-TEST ENABLED} - \text{SENSOR OUTPUT WITH SELF-TEST DISABLED}$$

When the value of the self-test response is within the specified min/max limits of the product specification, the part has passed self-test. When the self-test response exceeds the min/max values, the part is deemed to have failed self-test. It is recommended to use TDK-InvenSense MotionApps software for executing self-test.

4.12 CLOCKING

The ICM-20789 has a flexible clocking scheme, allowing a variety of internal clock sources to be used for the internal synchronous circuitry. This synchronous circuitry includes the signal conditioning and ADCs, the DMP, and various control circuits and registers. An on-chip PLL provides flexibility in the allowable inputs for generating this clock.

Allowable internal sources for generating the internal clock are:

- a) An internal relaxation oscillator
- b) Auto-select between internal relaxation oscillator and gyroscope MEMS oscillator to use the best available source

The only setting supporting specified performance in all modes is option b). It is recommended that option b) be used.

4.13 SENSOR DATA REGISTERS

The sensor data registers contain the latest gyroscope, accelerometer, and temperature measurement data. They are read-only registers, and are accessed via the serial interface. Data from these registers may be read anytime.

4.14 FIFO

The ICM-20789 contains a 4 kB FIFO register that is accessible via the Serial Interface. The FIFO configuration register determines which data is written into the FIFO. Possible choices include gyro data, accelerometer data, temperature readings, and FSYNC input. A FIFO counter keeps track of how many bytes of valid data are contained in the FIFO. The FIFO register supports burst reads. The interrupt function may be used to determine when new data is available.

The ICM-20789 allows FIFO read in low-power accelerometer mode.

4.15 INTERRUPTS

Interrupt functionality is configured via the Interrupt Configuration register. Items that are configurable include the INT pin configuration, the interrupt latching and clearing method, and triggers for the interrupt. Items that can trigger an interrupt are (1) Clock generator locked to new reference oscillator (used when switching clock sources); (2) new data is available to be read (from the FIFO and Data registers); (3) accelerometer event interrupts; (4) DMP; (5) FIFO overflow. The interrupt status can be read from the Interrupt Status register.

4.16 DIGITAL-OUTPUT TEMPERATURE SENSOR

An on-chip temperature sensor and ADC are used to measure the 6-axis motion die temperature. Another on-chip temperature sensor is present in the pressure sensor die. The readings from the ADC can be read from the FIFO or the Sensor Data registers.

4.17 BIAS AND LDOS

The bias and LDO section generates the internal supply and the reference voltages and currents required by the ICM-20789. Its two inputs are an unregulated VDD and a VDDIO logic reference supply voltage. The LDO output is bypassed by a capacitor at REGOUT. For further details on the capacitor, please refer to the Bill of Materials for External Components.

4.18 CHARGE PUMP

An on-chip charge pump generates the high voltage required for the MEMS oscillator.

4.19 STANDARD POWER MODES – UPDATE THE POWER MODES

The following table lists the user-accessible power modes for ICM-20789.

MODE	NAME	GYRO	ACCEL	DMP	PRESSURE
1	Sleep Mode	Off	Off	Off	Off
2	Standby Mode	Drive On	Off	Off	Off
3	Accelerometer Low-Power Mode	Off	Duty-Cycled	On or Off	On or Off
4	Accelerometer Low-Noise Mode	Off	On	On or Off	On or Off
5	Gyroscope Low-Power Mode	Duty-Cycled	Off	On or Off	On or Off
6	Gyroscope Low-Noise Mode	On	Off	On or Off	On or Off
7	6-Axis Low-Noise Mode	On	On	On or Off	On or Off
8	6-Axis Low-Power Mode	Duty-Cycled	On	On or Off	On or Off
9	Pressure sensor Low Noise Mode	On	On	On or Off	On
10	Pressure Sensor Low Power Mode	Duty-Cycled	On	On or Off	On

Table 16. Standard Power Modes for ICM-20789

5 PROGRAMMABLE INTERRUPTS

The ICM-20789 has a programmable interrupt system which can generate an interrupt signal on the INT pin. Status flags indicate the source of an interrupt. Interrupt sources may be enabled and disabled individually.

INTERRUPT NAME	MODULE
Motion Detection	Motion
FIFO Overflow	FIFO
Data Ready	Sensor Registers
DMP	DMP

Table 17. Table of Interrupt Sources

5.1 PER AXIS WAKE-ON-MOTION INTERRUPT

The ICM-20789 provides motion detection capability. A qualifying motion sample is one where the high passed sample from any axis has an absolute value exceeding a user-programmable threshold. The following steps explain how to configure the Wake-on-Motion Interrupt.

Step 1: Ensure that Accelerometer is running

- In PWR_MGMT_1 register (0x6B) set CYCLE = 0, SLEEP = 0, and GYRO_STANDBY = 0
- In PWR_MGMT_2 register (0x6C) set DISABLE_XA = DISABLE_YA = DISABLE_ZA = 0, and DISABLE_XG = DISABLE_YG = DISABLE_ZG = 1

Step 2: Accelerometer Configuration

1. In ACCEL_CONFIG2 register (0x1D) set ACCEL_FCHOICE_B = 0 and A_DLPF_CFG [2:0] = 1 (b001)

Step 3: Enable Motion Interrupt

2. In INT_ENABLE register (0x38) set WOM_X_INT_EN = WOM_Y_INT_EN = WOM_Z_INT_EN = 1 to enable motion interrupt per axis.

Step 4: Set Motion Threshold

3. Set the motion threshold in ACCEL_WOM_X_THR (0x20), ACCEL_WOM_Y_THR (0x21), ACCEL_WOM_Z_THR (0x22)

Step 5: Enable Accelerometer Hardware Intelligence

4. In ACCEL_INTEL_CTRL register (0x69) set ACCEL_INTEL_EN = ACCEL_INTEL_MODE = 1; Ensure that bit 0 is set to 0.

Step 6: Set Frequency of Wake-Up

5. In SMPLRT_DIV register (0x19) set SMPLRT_DIV [7:0] = 3.9 Hz – 500 Hz

Step 7: Enable Cycle Mode (Accelerometer Low-Power Mode)

6. In PWR_MGMT_1 register (0x6B) set CYCLE = 1

6 DIGITAL INTERFACE

6.1 I²C SERIAL INTERFACE

The internal registers and memory of the ICM-20789 can be accessed using either I²C at 400 kHz.

PIN NUMBER	PIN NAME	PIN DESCRIPTION
9	AD0	I ² C Slave Address LSB (AD0)
23	SCL	I ² C serial clock (SCL)
24	SDA	I ² C serial data (SDA)

Table 18. Serial Interface

6.2 I²C INTERFACE

I²C is a two-wire interface comprised of the signals serial data (SDA) and serial clock (SCL). In general, the lines are open-drain and bi-directional. In a generalized I²C interface implementation, attached devices can be a master or a slave. The master device puts the slave address on the bus, and the slave device with the matching address acknowledges the master.

The ICM-20789 always operates as a slave device when communicating to the system processor, which thus acts as the master. SDA and SCL lines typically need pull-up resistors to VDDIO. The maximum bus speed is 400 kHz.

The slave address of the ICM-20789 is b110100X which is 7 bits long. The LSB bit of the 7-bit address is determined by the logic level on pin AD0. This allows two ICM-20789s to be connected to the same I²C bus. When used in this configuration, the address of one of the devices should be b1101000 (pin AD0 is logic low) and the address of the other should be b1101001 (pin AD0 is logic high).

6.3 I²C COMMUNICATIONS PROTOCOL (6-AXIS ONLY. FOR PRESSURE PLEASE SEE CHAPTER 10)

START (S) and STOP (P) Conditions

Communication on the I²C bus starts when the master puts the START condition (S) on the bus, which is defined as a HIGH-to-LOW transition of the SDA line while SCL line is HIGH (see figure below). The bus is considered to be busy until the master puts a STOP condition (P) on the bus, which is defined as a LOW to HIGH transition on the SDA line while SCL is HIGH (see figure below).

Additionally, the bus remains busy if a repeated START (Sr) is generated instead of a STOP condition.

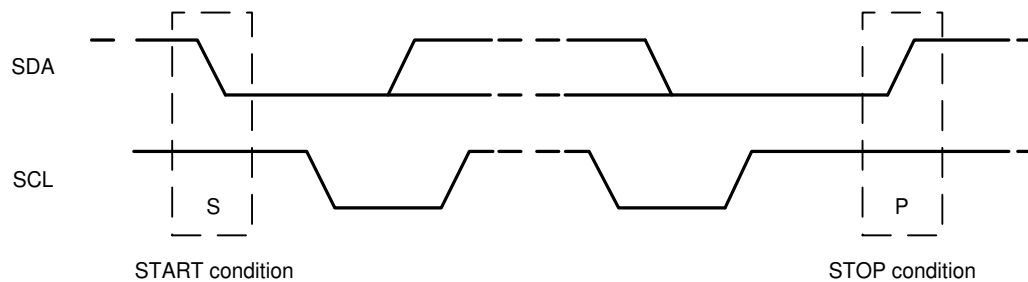

Figure 11. START and STOP Conditions

Data Format / Acknowledge

I²C data bytes are defined to be 8 bits long. There is no restriction to the number of bytes transmitted per data transfer. Each byte transferred must be followed by an acknowledge (ACK) signal. The clock for the acknowledge signal is generated by the master, while the receiver generates the actual acknowledge signal by pulling down SDA and holding it low during the HIGH portion of the acknowledge clock pulse.

If a slave is busy and cannot transmit or receive another byte of data until some other task has been performed, it can hold SCL LOW, thus forcing the master into a wait state. Normal data transfer resumes when the slave is ready, and releases the clock line (refer to the following figure).

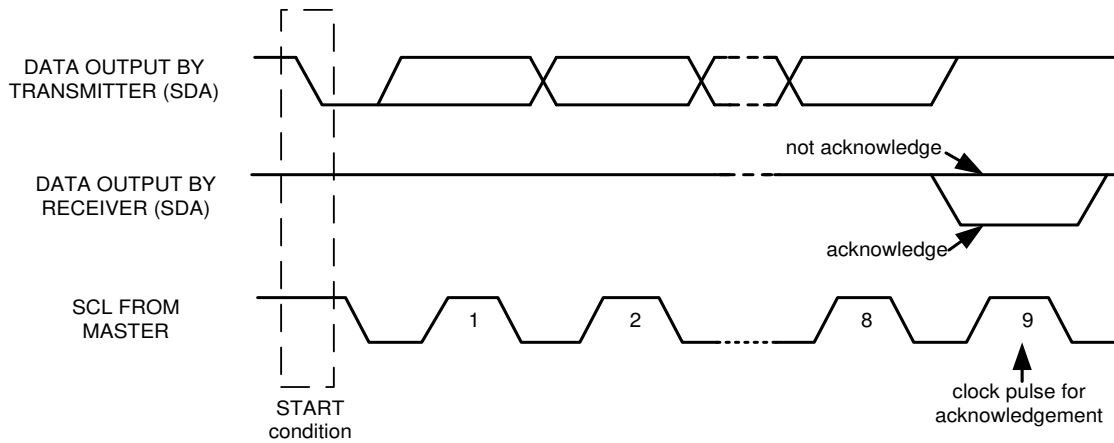

Figure 12. Acknowledge on the I²C Bus

Communications

After beginning communications with the START condition (S), the master sends a 7-bit slave address followed by an 8th bit, the read/write bit. The read/write bit indicates whether the master is receiving data from or is writing to the slave device. Then, the master releases the SDA line and waits for the acknowledge signal (ACK) from the slave device. Each byte transferred must be followed by an acknowledge bit. To acknowledge, the slave device pulls the SDA line LOW and keeps it LOW for the high period of the SCL line. Data transmission is always terminated by the master with a STOP condition (P), thus freeing the communications line. However, the master can generate a repeated START condition (Sr), and address another slave without first generating a STOP condition (P). A LOW to HIGH transition on the SDA line while SCL is HIGH defines the stop condition. All SDA changes should take place when SCL is low, with the exception of start and stop conditions.

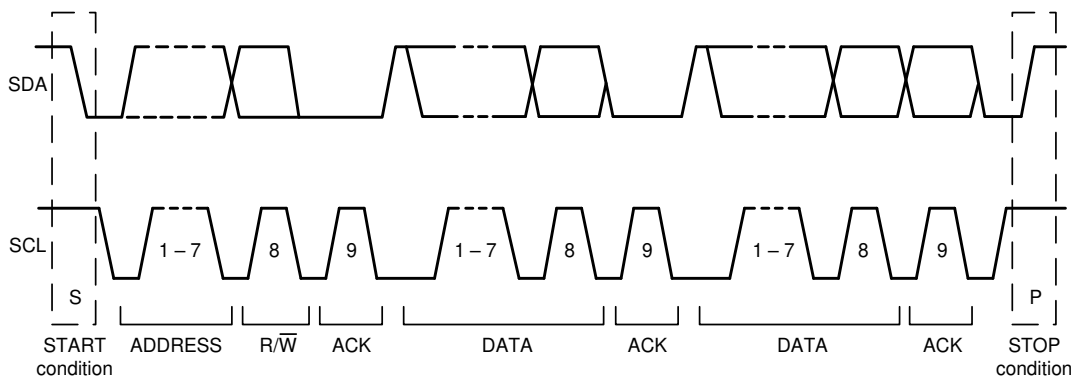

Figure 13. Complete I²C Data Transfer

To write the internal ICM-20789 registers, the master transmits the start condition (S), followed by the I²C address and the write bit (0). At the 9th clock cycle (when the clock is high), the ICM-20789 acknowledges the transfer. Then the master puts the register address (RA) on the bus. After the ICM-20789 acknowledges the reception of the register address, the master puts the register data onto the bus. This is followed by the ACK signal, and data transfer may be concluded by the stop condition (P). To write multiple bytes after the last ACK signal, the master can continue outputting data rather than transmitting a stop signal. In this case, the ICM-20789 automatically increments the register address and loads the data to the appropriate register. The following figures show single and two-byte write sequences.

Single-Byte Write Sequence

Master	S	AD+W		RA		DATA		P
Slave			ACK		ACK		ACK	

Burst Write Sequence

Master	S	AD+W		RA		DATA		DATA		P
Slave			ACK		ACK		ACK		ACK	

To read the internal ICM-20789 registers, the master sends a start condition, followed by the I²C address and a write bit, and then the register address that is going to be read. Upon receiving the ACK signal from the ICM-20789, the master transmits a start signal followed by the slave address and read bit. As a result, the ICM-20789 sends an ACK signal and the data. The communication ends with a not acknowledge (NACK) signal and a stop bit from master. The NACK condition is defined such that the SDA line remains high at the 9th clock cycle. The following figures show single and two-byte read sequences.

Single-Byte Read Sequence

Master	S	AD+W		RA		S	AD+R			NACK	P
Slave			ACK		ACK			ACK	DATA		

Burst Read Sequence

Master	S	AD+W		RA		S	AD+R			ACK		NACK	P
Slave			ACK		ACK			ACK	DATA		DATA		

6.4 I²C TERMS

SIGNAL	DESCRIPTION
S	Start Condition: SDA goes from high to low while SCL is high
AD	Slave I ² C address
W	Write bit (0)
R	Read bit (1)
ACK	Acknowledge: SDA line is low while the SCL line is high at the 9 th clock cycle
NACK	Not-Acknowledge: SDA line stays high at the 9 th clock cycle
RA	ICM-20789 internal register address
DATA	Transmit or received data
P	Stop condition: SDA going from low to high while SCL is high

Table 19. I²C Term SPI Interface

SPI is a 4-wire synchronous serial interface that uses two control lines and two data lines. The ICM-20789 always operates as a Slave device during standard Master-Slave SPI operation (6-Axis only).

With respect to the Master, the Serial Clock output (SPC), the Serial Data Output (SDO) and the Serial Data Input (SDI) are shared among the Slave devices. Each SPI slave device requires its own Chip Select (CS) line from the master.

CS goes low (active) at the start of transmission and goes back high (inactive) at the end. Only one CS line is active at a time, ensuring that only one slave is selected at any given time. The CS lines of the non-selected slave devices are held high, causing their SDO lines to remain in a high-impedance (high-z) state so that they do not interfere with any active devices.

SPI Operational Features

1. Data is delivered MSB first and LSB last
2. Data is latched on the rising edge of SPC
3. Data should be transitioned on the falling edge of SPC
4. The maximum frequency of SPC is 8 MHz
5. SPI read and write operations are completed in 16 or more clock cycles (two or more bytes). The first byte contains the SPI Address, and the following byte(s) contain(s) the SPI data. The first bit of the first byte contains the Read/Write bit and indicates the Read (1) or Write (0) operation. The following 7 bits contain the Register Address. In cases of multiple-byte Read/Writes, data is two or more bytes:

SPI Address format

MSB							LSB
R/W	A6	A5	A4	A3	A2	A1	A0

SPI Data format

MSB							LSB
D7	D6	D5	D4	D3	D2	D1	D0

6. Supports Single or Burst Read/Writes.

7 SERIAL INTERFACE CONSIDERATIONS

7.1 ICM-20789 SUPPORTED INTERFACES

The ICM-20789 supports I²C communications on its serial interface. The ICM-20789's I/O logic levels are set to be VDDIO. The figure below depicts a sample circuit of ICM-20789. It shows the relevant logic levels and voltage connections.

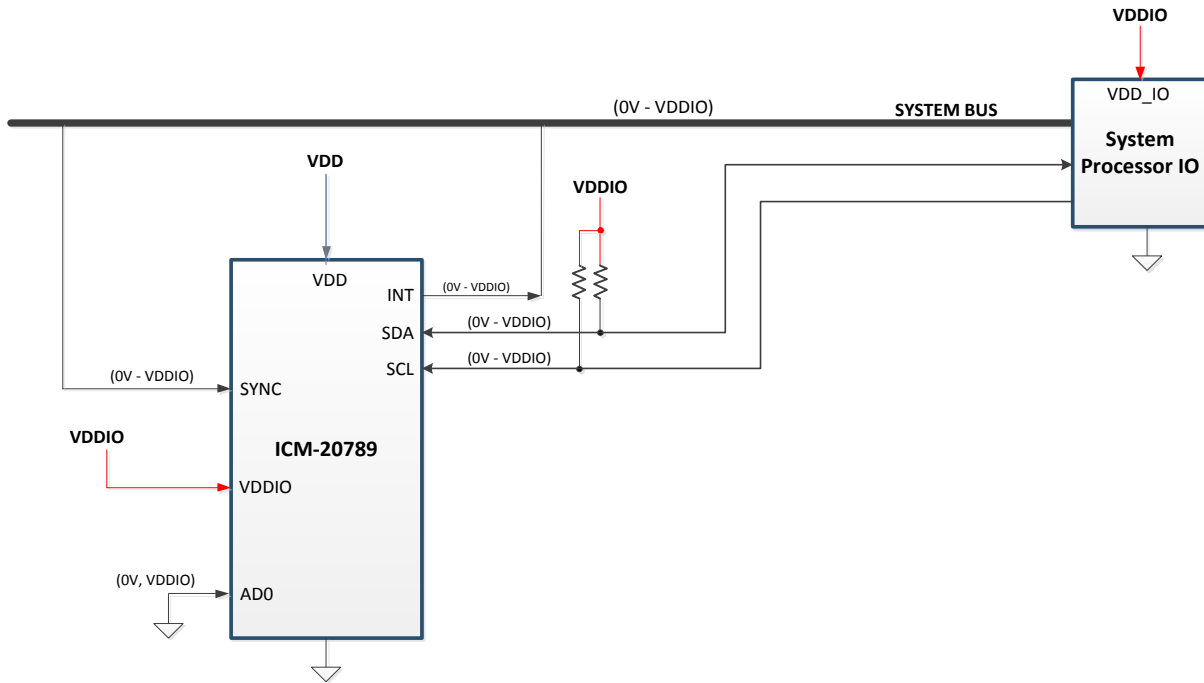

Figure 14. I/O Levels and Connections

8 REGISTER MAP

Addr. (Dec)	Addr (Hex)	Register Names	Bit7	Bit6	Bit5	Bit4	Bit3	Bit2	Bit1	Bit0	
0	00	SELF_TEST X GYRO	XG_ST_DATA[7:0]								
1	01	SELF_TEST Y GYRO	YG_ST_DATA[7:0]								
2	02	SELF_TEST Z GYRO	ZG_ST_DATA[7:0]								
13	0D	SELF_TEST4(X ACCEL)	XA_ST_DATA[7:0]								
14	0E	SELF_TEST5(Y ACCEL)	YA_ST_DATA[7:0]								
15	0F	SELF_TEST6(Z ACCEL)	ZA_ST_DATA[7:0]								
19	13	XG_OFFS_USRH	X_OFFS_USR[15:8]								
20	14	XG_OFFS_USRL	X_OFFS_USR[7:0]								
21	15	YG_OFFS_USRH	Y_OFFS_USR[15:8]								
22	16	YG_OFFS_USRL	Y_OFFS_USR[7:0]								
23	17	ZG_OFFS_USRH	Z_OFFS_USR[15:8]								
24	18	ZG_OFFS_USRL	Z_OFFS_USR[7:0]								
25	19	SMPLRT_DIV	SMPLRT_DIV[7:0]								
26	1A	CONFIG	FIFO_COUNT_REC	FIFO_MODE	EXT_SYNC_SET[2:0]			DLPF_CFG[2:0]			
27	1B	GYRO CONFIG	XGYRO_STEN	YGYRO_STEN	ZGYRO_STEN	GYRO_FS_SEL[1:0]		-	FCHOICE_B[1:0]		
28	1C	ACCEL_CONFIG	AX_ST_EN	AY_ST_EN	AZ_ST_EN	ACCEL_FS_SEL[4:3]		-	-	-	
29	1D	ACCEL_CONFIG2	FIFO_SIZE[1:0]		DEC2_CFG[5:4]		ACCEL_FCHOICE_B	A_DLPF_CFG[2:0]			
30	1E	LP_MODE_CTRL	GYRO_CYCLE	GYRO_AVGCFG[2:0]			LPOSC_CLKSEL2[3:0]				
32	20	ACCEL_WOM_X_THR	WOM_X_THRESHOLD[7:0]								
33	21	ACCEL_WOM_Y_THR	WOM_Y_THRESHOLD[7:0]								
34	22	ACCEL_WOM_Z_THR	WOM_Z_THRESHOLD[7:0]								
35	23	FIFO_EN	TEMP_OUT	GYRO_XOUT	GYRO_YOUT	GYRO_ZOUT	ACCEL_XYZ_OUT	-	-	-	
55	37	INT_PIN_CFG	ACTL	OPEN	LATCH_INT_EN	INT_ANYRD_2CLEAR	ACTL_FSYNC	FSYNC_INT_MODE_EN	BYPASS_EN	-	
56	38	INT_ENABLE	WOM_X_INT_EN	WOM_Y_INT_EN	WOM_Z_INT_EN	FIFO_OVERFLOW_EN	-	GDRIVE_RDY_EN	DMP_INT_EN	RAW_RDY_EN	
57	39	DMP_INT_STATUS	-	FIFO_WM_INT	DMP_INT [5:0]					-	-
58	3A	INT_STATUS	WOM_X_INT	WOM_Y_INT	WOM_Z_INT	FIFO_OVERFLOW_INT	-	GDRIVE_RDY_INT	DMP_INT	RAW_DATA_RDY_INT	
59	3B	ACCEL_XOUT_H	ACCEL_XOUT_H [15:8]								
60	3C	ACCEL_XOUT_L	ACCEL_XOUT_L [7:0]								
61	3D	ACCEL_YOUT_H	ACCEL_YOUT_H [15:8]								
62	3E	ACCEL_YOUT_L	ACCEL_YOUT_L [7:0]								
63	3F	ACCEL_ZOUT_H	ACCEL_ZOUT_H [15:8]								
64	40	ACCEL_ZOUT_L	ACCEL_ZOUT_L [7:0]								
65	41	TEMP_OUT_H	TEMP_OUT_H [15:8]								
66	42	TEMP_OUT_L	TEMP_OUT_L [7:0]								
67	43	GYRO_XOUT_H	GYRO_XOUT_H [15:8]								
68	44	GYRO_XOUT_L	GYRO_XOUT_L [7:0]								
69	45	GYRO_YOUT_H	GYRO_YOUT_H [15:8]								
70	46	GYRO_YOUT_L	GYRO_YOUT_L [7:0]								
71	47	GYRO_ZOUT_H	GYRO_ZOUT_H [15:8]								
72	48	GYRO_ZOUT_L	GYRO_ZOUT_L [7:0]								
104	68	SIGNAL_PATH_RESET	-	-	-	-	-	GYRO_RST	ACCEL_RST	TEMP_RST	
105	69	ACCEL_INTEL_CTRL	ACCEL_INTEL_EN	ACCEL_INTEL_MODE	-	-	-	-	-	-	

Addr. (Dec)	Addr (Hex)	Register Names	Bit7	Bit6	Bit5	Bit4	Bit3	Bit2	Bit1	Bit0
106	6A	USER_CTRL	DMP_EN	FIFO_EN	-	I2C_IF_DIS	DMP_RST	FIFO_RST	-	SIG_COND_RST
107	6B	PWR_MGMT_1	DEVICE_RESET	SLEEP	ACCEL_CYCLE	GYRO_STANDBY	TEMP_DIS	CLKSEL[2:0]		
108	6C	PWR_MGMT_2	LP_DIS	DMP_LP_DIS	DISABLE_XA	DISABLE_YA	DISABLE_ZA	DISABLE_XG	DISABLE_YG	DISABLE_ZG
114	72	FIFO_COUNTH	FIFO_COUNTH[12:8]							
115	73	FIFO_COUNTL	FIFO_COUNTL[7:0]							
116	74	FIFO_R_W	FIFO_R_W[7:0]							
117	75	WHO_AM_I	WHO_AM_I[7:0]							
119	77	XA_OFFS_H	XA_OFFSH[14:7]							
120	78	XA_OFFS_L	XA_OFFSL[6:0]							-
122	7A	YA_OFFS_H	YA_OFFSH[14:7]							
123	7B	YA_OFFS_L	YA_OFFSL[6:0]							-
125	7D	ZA_OFFS_H	ZA_OFFSH[14:7]							
126	7E	ZA_OFFS_L	ZA_OFFSL[6:0]							-

Table 20. Register Map

Note: Register Names ending in `_H` and `_L` contain the high and low bytes, respectively, of an internal register value.

In the detailed register tables that follow, register names are in capital letters, while register values are in capital letters and italicized. For example, the `ACCEL_XOUT_H` register (Register 59) contains the 8 most significant bits, *ACCEL_XOUT[15:8]*, of the 16-bit X-Axis accelerometer measurement, *ACCEL_XOUT*.

The reset value is 0x00 for all registers other than the registers below, also the self-test registers contain pre-programmed values and will not be 0x00 after reset.

- Register 107 (0x40) Power Management 1
- Register 117 (0x03) WHO_AM_I for ICM-20789

9 REGISTER DESCRIPTIONS

This section describes the function and contents of each register within the ICM-20789.

Note: The device will come up in sleep mode upon power-up.

9.1 REGISTERS DESCRIPTIONS

Reset values are “0” for all registers, unless otherwise specified

9.2 REGISTERS 0 TO 2 – SELF-TEST REGISTERS

Register Name: SELF_TEST X GYRO, SELF_TEST Y GYRO, SELF_TEST Z GYRO

Type: USR/CFG

Register Address: 0, 1, 2 (Decimal); 00, 01, 02 (Hex)

REGISTER	BIT	NAME	FUNCTION
SELF_TEST X GYRO	[7:0]	XG_ST_DATA	The value in this register indicates the self-test output generated during manufacturing tests. This value is to be used to check against subsequent self-test outputs performed by the end user.
SELF_TEST Y GYRO	[7:0]	YG_ST_DATA	The value in this register indicates the self-test output generated during manufacturing tests. This value is to be used to check against subsequent self-test outputs performed by the end user.
SELF_TEST Z GYRO	[7:0]	ZG_ST_DATA	The value in this register indicates the self-test output generated during manufacturing tests. This value is to be used to check against subsequent self-test outputs performed by the end user.

9.3 REGISTERS 13 TO 15

Register Name: SELF_TEST4(X ACCEL), SELF_TEST5(Y ACCEL), SELF_TEST6(Z ACCEL)

Register Type: USR/CFG

Register Address: 13, 14, 15 (Decimal); 0D, 0E, 0F (Hex)

REGISTER	BIT	NAME	FUNCTION
SELF_TEST4(X ACCEL)	[7:0]	XA_ST_DATA[7:0]	Contains self-test data for the X Accelerometer
SELF_TEST5(Y ACCEL)	[7:0]	YA_ST_DATA[7:0]	Contains self-test data for the Y Accelerometer
SELF_TEST6(Z ACCEL)	[7:0]	ZA_ST_DATA[7:0]	Contains self-test data for the Z Accelerometer

9.4 REGISTER 19 – GYRO OFFSET ADJUSTMENT REGISTER

Register Name: XG_OFFS_USRH

Register Type: USR

Register Address: 19 (Decimal); 13 (Hex)

BIT	NAME	FUNCTION
[7:0]	X_OFFS_USR[15:8]	Bits 15 to 8 of the 16-bit offset of X gyroscope (2’s complement). This register is used to remove DC bias from the sensor output. The value in this register is added to the gyroscope sensor value before going into the sensor register.

9.5 REGISTER 20 – GYRO OFFSET ADJUSTMENT REGISTER

Register Name: XG_OFFS_USRL

Register Type: USR

Register Address: 20 (Decimal); 14 (Hex)

BIT	NAME	FUNCTION
[7:0]	X_OFFS_USR[7:0]	Bits 7 to 0 of the 16-bit offset of X gyroscope (2’s complement). This register is used to remove DC bias from the sensor output. The value in this register is added to the gyroscope sensor value before going into the sensor register.

9.6 REGISTER 21 – GYRO OFFSET ADJUSTMENT REGISTER

Register Name: YG_OFFS_USRH

Register Type: USR

Register Address: 21 (Decimal); 15 (Hex)

INTBIT	NAME	FUNCTION
[7:0]	Y_OFFS_USR[15:8]	Bits 15 to 8 of the 16-bit offset of Y gyroscope (2's complement). This register is used to remove DC bias from the sensor output. The value in this register is added to the gyroscope sensor value before going into the sensor register.

9.7 REGISTER 22 – GYRO OFFSET ADJUSTMENT REGISTER

Register Name: YG_OFFS_USRL

Register Type: USR

Register Address: 22 (Decimal); 16 (Hex)

BIT	NAME	FUNCTION
[7:0]	Y_OFFS_USR[7:0]	Bits 7 to 0 of the 16-bit offset of Y gyroscope (2's complement). This register is used to remove DC bias from the sensor output. The value in this register is added to the gyroscope sensor value before going into the sensor register.

9.8 REGISTER 23 – GYRO OFFSET ADJUSTMENT REGISTER

Register Name: ZG_OFFS_USRH

Register Type: USR

Register Address: 23 (Decimal); 17 (Hex)

BIT	NAME	FUNCTION
[7:0]	Z_OFFS_USR[15:8]	Bits 15 to 8 of the 16-bit offset of Z gyroscope (2's complement). This register is used to remove DC bias from the sensor output. The value in this register is added to the gyroscope sensor value before going into the sensor register.

9.9 REGISTER 24 – GYRO OFFSET ADJUSTMENT REGISTER

Register Name: ZG_OFFS_USRL

Register Type: USR

Register Address: 24 (Decimal); 18 (Hex)

BIT	NAME	FUNCTION
[7:0]	Z_OFFS_USR[7:0]	Bits 7 to 0 of the 16-bit offset of Z gyroscope (2's complement). This register is used to remove DC bias from the sensor output. The value in this register is added to the gyroscope sensor value before going into the sensor register.

9.10 REGISTER 25 – SAMPLE RATE DIVIDER.

Register Name: SMPLRT_DIV

Register Type: USR

Register Address: 25 (Decimal); 19 (Hex)

BIT	NAME	FUNCTION
[7:0]	SMPLRT_DIV[7:0]	Divides the internal sample rate (see register CONFIG (0x1A)) to generate the sample rate that controls sensor data output rate, FIFO sample rate. Note: This register is only effective when FCHOICE_B register bits are 2'b00, and (0 < DLPF_CFG < 7). This is the update rate of the sensor register: $SAMPLE_RATE = INTERNAL_SAMPLE_RATE / (1 + SMPLRT_DIV)$ Where $INTERNAL_SAMPLE_RATE = 1\text{ kHz}$

9.11 REGISTER 26 – CONFIGURATION

Register Name: CONFIG

Register Type: USR

Register Address: 26 (Decimal); 1A (Hex)

BIT	NAME	FUNCTION																		
[7]	FIFO_COUNT_REC	Always set to 0.																		
[6]	FIFO_MODE	When set to '1', when the fifo is full, additional writes will not be written to fifo. When set to '0', when the fifo is full, additional writes will be written to the fifo, replacing the oldest data.																		
[5:3]	EXT_SYNC_SET[2:0]	Enables the FSYNC pin data to be sampled. <table border="1"> <thead> <tr> <th>EXT_SYNC_SET</th> <th>FSYNC bit location</th> </tr> </thead> <tbody> <tr> <td>0</td> <td>function disabled</td> </tr> <tr> <td>1</td> <td>TEMP_OUT_L[0]</td> </tr> <tr> <td>2</td> <td>GYRO_XOUT_L[0]</td> </tr> <tr> <td>3</td> <td>GYRO_YOUT_L[0]</td> </tr> <tr> <td>4</td> <td>GYRO_ZOUT_L[0]</td> </tr> <tr> <td>5</td> <td>ACCEL_XOUT_L[0]</td> </tr> <tr> <td>6</td> <td>ACCEL_YOUT_L[0]</td> </tr> <tr> <td>7</td> <td>ACCEL_ZOUT_L[0]</td> </tr> </tbody> </table>	EXT_SYNC_SET	FSYNC bit location	0	function disabled	1	TEMP_OUT_L[0]	2	GYRO_XOUT_L[0]	3	GYRO_YOUT_L[0]	4	GYRO_ZOUT_L[0]	5	ACCEL_XOUT_L[0]	6	ACCEL_YOUT_L[0]	7	ACCEL_ZOUT_L[0]
EXT_SYNC_SET	FSYNC bit location																			
0	function disabled																			
1	TEMP_OUT_L[0]																			
2	GYRO_XOUT_L[0]																			
3	GYRO_YOUT_L[0]																			
4	GYRO_ZOUT_L[0]																			
5	ACCEL_XOUT_L[0]																			
6	ACCEL_YOUT_L[0]																			
7	ACCEL_ZOUT_L[0]																			
[2:0]	DLPF_CFG[2:0]	For the DLPF to be used, FCHOICE_B[1:0] is 2'b00. See the table below.																		

The DLPF is configured by *DLPF_CFG*, when *FCHOICE_B* [1:0] = 2b'00. The gyroscope and temperature sensor are filtered according to the value of *DLPF_CFG* and *FCHOICE_B* as shown in the table below.

FCHOICE_B		DLPF_CFG	Gyroscope			Temperature Sensor
<1>	<0>		3-dB BW (Hz)	Noise BW (Hz)		3-dB BW (Hz)
X	1	X	8173	8595.1		4000
1	0	X	3281	3451.0		4000
0	0	0	250	306.6		4000
0	0	1	176	177.0		188
0	0	2	92	108.6		98
0	0	3	41	59.0		42
0	0	4	20	30.5		20
0	0	5	10	15.6		10
0	0	6	5	8.0		5
0	0	7	3281	3451.0		4000

9.12 REGISTER 27 – GYROSCOPE CONFIGURATION

Register Name: GYRO CONFIG

Register Type: USR

Register Address: 27 (Decimal); 1B (Hex)

BIT	NAME	FUNCTION
[7]	XGYRO_STEN	X Gyro self-test.
[6]	YGYRO_STEN	Y Gyro self-test.
[5]	ZGYRO_STEN	Z Gyro self-test.
[4:3]	GYRO_FS_SEL[1:0]	Gyro Full Scale Select: 00 = ±250 dps 01 = ±500 dps 10 = ± 1000 dps 11 = ±2000 dps
[2]	-	Reserved.
[1:0]	FCHOICE_B[1:0]	NOTE: Register is Fchoice_b (inverted version of Fchoice)

9.13 REGISTER 28 – ACCELEROMETER CONFIGURATION

Register Name: ACCEL_CONFIG

Register Type: USR

Register Address: 28 (Decimal); 1C (Hex)

BIT	NAME	FUNCTION
[7]	AX_ST_EN	X Accel self-test.
[6]	AY_ST_EN	Y Accel self-test.
[5]	AZ_ST_EN	Z Accel self-test.
[4:3]	ACCEL_FS_SEL[1:0]	Accel Full Scale Select: ±2g (00), ±4g (01), ±8g (10), ±16g (11)
[2:0]	-	Reserved.

9.14 REGISTER 29 – ACCELEROMETER CONFIGURATION 2

Register Name: ACCEL_CONFIG2

Register Type: USR

Register Address: 29 (Decimal); 1D (Hex)

BIT	NAME	FUNCTION
[7:6]	FIFO_SIZE[1:0]	Fifo size control: 0=512bytes, 1=1 KB, 2=2 KB, 3=4 KB NOTE: After the fifo size has been changed, the fifo should be reset.
[5:4]	DEC2_CFG	Controls the number of samples averaged in the accel decimator 2: 0 = average 4 samples 1 = average 8 samples 2 = average 16 samples 3 = average 32 samples
[3]	ACCEL_FCHOICE_B	Used to bypass DLPF as shown in table 2 below. NOTE: This register contains accel_fchoice_b (the inverted version of accel_fchoice as described in the table below).
[2:0]	A_DLPF_CFG	Accelerometer low pass filter setting as shown in table below.

ACCEL_FCHOICE_B	A_DLPF_CFG	Accelerometer
		3-dB BW (Hz)
1	X	1046.0
0	0	218.1
0	1	218.1
0	2	99.0
0	3	44.8
0	4	21.2
0	5	10.2
0	6	5.1
0	7	420.0

Table 21. Accelerometer Data Rates and Bandwidths (Low Noise Mode)

Notes:

1. The data rate out of the DLPF filter block can be further reduced by a factor of $1/(1+SMPLRT_DIV)$, where SMPLRT_DIV is an 8-bit integer.
2. Data should be sampled at or above sample rate; SMPLRT_DIV is only used for 1 kHz internal sampling.

In the low-power mode of operation, the accelerometer is duty-cycled. For each ODR, there are several bandwidth settings corresponding to different numbers of averages per measurement cycle of the Dec1 output.

ACCEL_FCHOICE_B	1	0	0	0	0	0
A_DLPF_CFG	x	7	7	7	7	7
DEC2_CFG	x	0	1	2	3	
Averages	1x	4x	8x	16x	32x	
Ton (ms)	1.084	1.84	2.84	4.84	8.84	
Noise BW (Hz)	1100.0	441.6	235.4	121.3	61.5	
Noise (mg) TYP based on 150 µg/√Hz	8.3	5.3	3.8	2.8	2.0	
SMP_LRT_DIV	ODR (Hz)	Current Consumption (µA) TYP				
255	3.9	8.4	9.4	10.8	13.6	19.2
127	7.8	9.8	11.9	14.7	20.3	31.4
63	15.6	12.8	17.0	22.5	33.7	55.9
31	31.3	18.7	27.1	38.2	60.4	104.9
15	62.5	30.4	47.2	69.4	113.9	202.8
7	125.0	57.4	87.5	132.0	220.9	N/A
3	250.0	100.9	168.1	257.0	N/A	
1	500.0	194.9	329.3	N/A		

Table 22. Accelerometer Data Rates and Bandwidths (Low-Power Mode)

- Gyros ON: When at least one axis of the Gyro is ON, then the ODR is determined by the gyro_fchoice and dlpf_cfg.
- Gyro OFF and normal Accel mode: When all the axes of Gyro are turned off and in normal Accel mode, then the ODR is determined by accel_fchoice and dlpf_cfg.
- Low power Accel mode: In low power Accel mode, the ODR is determined by Accel_fchoice and dec2_cfg

9.15 REGISTER 30 – LOW POWER MODE CONFIGURATION

Register Name: LP_MODE_CTRL

Register Type: USR

Register Address: 30 (Decimal); 1E (Hex)

BIT	NAME	FUNCTION
[7]	GYRO_CYCLE	Enable gyro duty cycling.
[6:4]	GYRO_AVGCFG[2:0]	Averaging filter configuration for gyro duty cycling.
[3:0]	LPOSC_CLKSEL[3:0]	Reserved.

To operate in gyroscope low-power mode or 6-axis low-power mode, GYRO_CYCLE should be set to '1.' Gyroscope filter configuration is determined by G_AVGCFG[2:0] that sets the averaging filter configuration. It is not dependent on DLPF_CFG[2:0].

The following table shows some example configurations for gyroscope low power mode.

FCHOICE_B	0	0	0	0	0	0	0	0	0
G_AVGCFG	0	1	2	3	4	5	6	7	
Averages	1x	2x	4x	8x	16x	32x	64x	128x	
Ton (ms)	1.73	2.23	3.23	5.23	9.23	17.23	33.23	65.23	
Noise BW (Hz)	650.8	407.1	224.2	117.4	60.2	30.6	15.6	8.0	
Noise (dps) TYP based on 0.006 dps/√Hz	0.15	0.12	0.09	0.07	0.05	0.03	0.02	0.02	
SMPLRT_DIV	ODR (Hz)	Current Consumption (mA) TYP							
255	3.9	1.3	1.3	1.3	1.3	1.4	1.4	1.5	1.8
99	10.0	1.3	1.3	1.4	1.4	1.5	1.6	1.9	2.5
64	15.4	1.4	1.4	1.4	1.5	1.6	1.8	2.2	N/A
32	30.3	1.4	1.4	1.5	1.6	1.8	2.2	N/A	
19	50.0	1.5	1.5	1.6	1.8	2.1	2.8	N/A	
9	100.0	1.6	1.7	1.9	2.2	3.0	N/A		
7	125.0	1.7	1.8	2.0	2.5	N/A			
4	200.0	1.9	2.1	2.5	N/A				
3	250.0	2.1	2.3	2.7	N/A				
2	333.3	2.3	2.6	N/A					
1	500.0	2.9	N/A						

9.16 REGISTER 32 – WAKE ON MOTION THRESHOLD

Register Name: ACCEL_WOM_X_THR

Register Type: USR

Register Address: 32 (Decimal); 20 (Hex)

BIT	NAME	FUNCTION
[7:0]	WOM_X_Threshold	Accel WOM threshold for x-axis.

9.17 REGISTER 33 – WAKE ON MOTION THRESHOLD

Register Name: ACCEL_WOM_Y_THR

Register Type: USR

Register Address: 33 (Decimal); 21 (Hex)

BIT	NAME	FUNCTION
[7:0]	WOM_Y_Threshold	Accel WOM threshold for y-axis.

9.18 REGISTER 34 – WAKE ON MOTION THRESHOLD

Register Name: ACCEL_WOM_Z_THR

Register Type: USR

Register Address: 34 (Decimal); 22 (Hex)

BIT	NAME	FUNCTION
[7:0]	WOM_Z_Threshold	Accel WOM threshold for z-axis.

9.19 REGISTER 35 – FIFO ENABLE

FIFO enable takes effect during the idle state of the sequence controller.

Register Name: FIFO_EN

Register Type: USR

Register Address: 35 (Decimal); 23 (Hex)

BIT	NAME	FUNCTION
[7]	TEMP_OUT	1 – Write TEMP_OUT_H and TEMP_OUT_L to the FIFO at the sample rate; If enabled, buffering of data occurs even if data path is in standby. 0 – Function is disabled.
[6]	GYRO_XOUT	1 – Write GYRO_XOUT_H and GYRO_XOUT_L to the FIFO at the sample rate; If enabled, buffering of data occurs even if data path is in standby. 0 – Function is disabled.
[5]	GYRO_YOUT	1 – Write GYRO_YOUT_H and GYRO_YOUT_L to the FIFO at the sample rate; If enabled, buffering of data occurs even if data path is in standby. 0 – Function is disabled. NOTE: Enabling any one of the bits corresponding to the Gyros or Temp data paths, data is buffered into the FIFO even though that data path is not enabled.
[4]	GYRO_ZOUT	1 – Write GYRO_ZOUT_H and GYRO_ZOUT_L to the FIFO at the sample rate; If enabled, buffering of data occurs even if data path is in standby. 0 – Function is disabled.
[3]	ACCEL_XYZ_OUT	1 – Write ACCEL_XOUT_H, ACCEL_XOUT_L, ACCEL_YOUT_H, ACCEL_YOUT_L, ACCEL_ZOUT_H, and ACCEL_ZOUT_L to the FIFO at the sample rate; 0 – Function is disabled.
[2]	-	Reserved.
[1]	-	Reserved.
[0]	-	Reserved.

9.20 REGISTER 55 – INTERRUPT/BYPASS PIN CONFIGURATION

Register Name: INT_PIN_CFG

Register Type: USR

Register Address: 55 (Decimal); 37 (Hex)

BIT	NAME	FUNCTION
[7]	ACTL	1 – The logic level for INT pin is active low. 0 – The logic level for INT pin is active high.
[6]	OPEN	1 – INT pin is configured as open drain. 0 – INT pin is configured as push-pull.
[5]	LATCH_INT_EN	1 – INT pin level held until interrupt status is cleared. 0 – INT pin indicates interrupt pulse's is width 50 μ s.
[4]	INT_ANYRD_2CLEAR	1 – Interrupt status is cleared if any read operation is performed. 0 – Interrupt status is cleared only by reading INT_STATUS register.
[3]	ACTL_FSYNC	1 – The logic level for the FSYNC pin as an interrupt is active low. 0 – The logic level for the FSYNC pin as an interrupt is active high.
[2]	FSYNC_INT_MODE_EN	1 – This enables the FSYNC pin to be used as an interrupt. A transition to the active level described by the ACTL_FSYNC bit will cause an interrupt. The status of the interrupt is read in the I ² C Master Status register PASS_THROUGH bit. 0 – This disables the FSYNC pin from causing an interrupt.
[1]	BYPASS_EN	When asserted, will go into 'bypass mode' where the I ² C master interface is disabled.
[0]	-	Reserved.

9.21 REGISTER 56 – INTERRUPT ENABLE

Register Name: INT_ENABLE

Register Type: USR

Register Address: 56 (Decimal); 38 (Hex)

BIT	NAME	FUNCTION
[7]	WOM_X_INT_EN	1 – Enable wake on motion interrupt on accel X-axis
[6]	WOM_Y_INT_EN	1 – Enable wake on motion interrupt on accel Y-axis,
[5]	WOM_Z_INT_EN	1 – Enable wake on motion interrupt on accel Z-axis
[4]	FIFO_OVERFLOW_EN	1 – Enable interrupt for FIFO overflow to propagate to interrupt pin. 0 – Function is disabled.
[3]	-	Reserved
[2]	GDRIVE_RDY_EN	1 – Enable gyro drive rdy interrupt to propagate to interrupt pin. 0 – Function is disabled.
[1]	DMP_INT_EN	1 – Enable DMP interrupt to propagate to interrupt pin. 0 – Function is disabled.
[0]	RAW_RDY_EN	1 – Enable Raw Sensor Data Ready interrupt to propagate to interrupt pin. 0 – Function is disabled.

9.22 REGISTER 57 – DMP INTERRUPT STATUS

Register Name: DMP_INT_STATUS

Register Type: USR

Register Address: 57 (Decimal); 39 (Hex)

BIT	NAME	FUNCTION
[6]	FIFO_WM_INT	Reserved.
[5:0]	DMP_INT	DMP Interrupt Status.

9.23 REGISTER 58 – INTERRUPT STATUS

Register Name: INT_STATUS

Register Type: USR

Register Address: 58 (Decimal); 3A (Hex)

BIT	NAME	FUNCTION
[7]	WOM_X_INT	Wake on motion interrupt triggered on x-axis.
[6]	WOM_Y_INT	Wake on motion interrupt triggered on y-axis.
[5]	WOM_Z_INT	Wake on motion interrupt triggered on z-axis.
[4]	FIFO_OVERFLOW_INT	1 – FIFO Overflow interrupt occurred. Note that the oldest data is has been dropped from the FIFO.
[3]	-	Reserved.
[2]	GDRIVE_RDY_INT	1 – Indicates that the gyro drive has been enabled and is ready.
[1]	DMP_INT	1 – The DMP has generated an Interrupt.
[0]	RAW_DATA_RDY_INT	1 – Sensor Register Raw Data sensors are updated and Ready to be read.

9.24 REGISTER 59 – ACCELEROMETER MEASUREMENTS

Register Name: ACCEL_XOUT_H

Register Type: USR

Register Address: 59 (Decimal); 3B (Hex)

BIT	NAME	FUNCTION
[7:0]	ACCEL_XOUT_H [15:8]	High byte of accelerometer x-axis data.

9.25 REGISTER 60 – ACCELEROMETER MEASUREMENTS

Register Name: ACCEL_XOUT_L

Register Type: USR

Register Address: 60 (Decimal); 3C (Hex)

BIT	NAME	FUNCTION
[7:0]	ACCEL_XOUT_L [7:0]	Low byte of accelerometer x-axis data.

9.26 REGISTER 61 – ACCELEROMETER MEASUREMENTS

Register Name: ACCEL_YOUT_H

Register Type: USR

Register Address: 61 (Decimal); 3D (Hex)

BIT	NAME	FUNCTION
[7:0]	ACCEL_YOUT_H [15:8]	High byte of accelerometer y-axis data.

9.27 REGISTER 62 – ACCELEROMETER MEASUREMENTS

Register Name: ACCEL_YOUT_L

Register Type: USR

Register Address: 62 (Decimal); 3E (Hex)

BIT	NAME	FUNCTION
[7:0]	ACCEL_YOUT_L [7:0]	Low byte of accelerometer y-axis data.

9.28 REGISTER 63 – ACCELEROMETER MEASUREMENTS

Register Name: ACCEL_ZOUT_H

Register Type: USR

Register Address: 63 (Decimal); 3F (Hex)

BIT	NAME	FUNCTION
[7:0]	ACCEL_ZOUT_H [15:8]	High byte of accelerometer z-axis data.

9.29 REGISTER 64 – ACCELEROMETER MEASUREMENTS

Register Name: ACCEL_ZOUT_L

Register Type: USR

Register Address: 64 (Decimal); 40 (Hex)

BIT	NAME	FUNCTION
[7:0]	ACCEL_ZOUT_L [7:0]	Low byte of accelerometer z-axis data.

9.30 REGISTER 65 – TEMPERATURE MEASUREMENT

Register Name: TEMP_OUT_H

Register Type: USR

Register Address: 65 (Decimal); 41 (Hex)

BIT	NAME	FUNCTION
[7:0]	TEMP_OUT_H[15:8]	High byte of the temperature sensor output.

9.31 REGISTER 66 – TEMPERATURE MEASUREMENT

Register Name: TEMP_OUT_L

Register Type: USR

Register Address: 66 (Decimal); 42 (Hex)

BIT	NAME	FUNCTION
[7:0]	TEMP_OUT_L[7:0]	Low byte of the temperature sensor output.

9.32 REGISTER 67 – GYROSCOPE MEASUREMENT

Register Name: GYRO_XOUT_H

Register Type: USR

Register Address: 67 (Decimal); 43 (Hex)

BIT	NAME	FUNCTION
[7:0]	GYRO_XOUT_H[15:8]	High byte of the x-axis gyroscope output.

9.33 REGISTER 68 – GYROSCOPE MEASUREMENT

Register Name: GYRO_XOUT_L

Register Type: USR

Register Address: 68 (Decimal); 44 (Hex)

BIT	NAME	FUNCTION
[7:0]	GYRO_XOUT_L[7:0]	Low byte of the x-axis gyroscope output.

9.34 REGISTER 69 – GYROSCOPE MEASUREMENT

Register Name: GYRO_YOUT_H

Register Type: USR

Register Address: 69 (Decimal); 45 (Hex)

BIT	NAME	FUNCTION
[7:0]	GYRO_YOUT_H[15:8]	High byte of the y-axis gyroscope output.

9.35 REGISTER 70 – GYROSCOPE MEASUREMENT

Register Name: GYRO_YOUT_L

Register Type: USR

Register Address: 70 (Decimal); 46 (Hex)

BIT	NAME	FUNCTION
[7:0]	GYRO_YOUT_L[7:0]	Low byte of the y-axis gyroscope output.

9.36 REGISTER 71 – GYROSCOPE MEASUREMENT

Register Name: GYRO_ZOUT_H

Register Type: USR

Register Address: 71 (Decimal); 47 (Hex)

BIT	NAME	FUNCTION
[7:0]	GYRO_ZOUT_H[15:8]	High byte of the z-axis gyroscope output.

9.37 REGISTER 72 – GYROSCOPE MEASUREMENT

Register Name: GYRO_ZOUT_L

Register Type: USR

Register Address: 72 (Decimal); 48 (Hex)

BIT	NAME	FUNCTION
[7:0]	GYRO_ZOUT_L[7:0]	Low byte of the z-axis gyroscope output.

9.38 REGISTER 104 – SIGNAL PATH RESET

Register Name: SIGNAL_PATH_RESET

Register Type: USR/CFG

Register Address: 104 (Decimal); 68 (Hex)

BIT	NAME	FUNCTION
[7:3]	-	Reserved.
[2]	GYRO_RST	Reset gyro digital signal path. Note: Sensor registers are not cleared. Use SIG_COND_RST to clear sensor registers.
[1]	ACCEL_RST	Reset accel digital signal path. Note: Sensor registers are not cleared. Use SIG_COND_RST to clear sensor registers.
[0]	TEMP_RST	Reset temp digital signal path. Note: Sensor registers are not cleared. Use SIG_COND_RST to clear sensor registers.

9.39 REGISTER 105 – ACCELEROMETER INTELLIGENCE CONTROL

Register Name: ACCEL_INTEL_CTRL

Register Type: USR/CFG

Register Address: 105 (Decimal); 69 (Hex)

BIT	NAME	FUNCTION
[7]	ACCEL_INTEL_EN	Enable the WOM logic.
[6]	ACCEL_INTEL_MODE	This bit defines 1 = compare the current sample with the previous sample. 0 = initial sample is stored; all future samples are compared to the initial sample.
[5:4]	-	Reserved.
[3:2]	-	Reserved.
1	-	Reserved.
0	-	Reserved.

9.40 REGISTER 106 – USER CONTROL

Register Name: USER_CTRL

Register Type: USR/CFG

Register Address: 106 (Decimal); 6A (Hex)

BIT	NAME	FUNCTION
[7]	DMP_EN	1 – Enable DMP operation mode. 0 – Freeze DMP processing after DMP Done (finish) with current processing sample. NOTE: DMP will run when enabled, even if all sensors are disabled, except when the sample rate is set to 8 kHz.
[6]	FIFO_EN	1 – Enable FIFO operation mode. 0 – Disable FIFO access from serial interface. To disable FIFO writes by dma, use FIFO_EN register. To disable possible FIFO writes from dmp, disable the dmp.
[5]	-	Reserved.
[4]	I2C_IF_DIS	1 – Reset I ² C Slave module.
[3]	DMP_RST	1 – Reset DMP module. Reset is asynchronous. This bit auto clears after one clock cycle.
[2]	FIFO_RST	1 – Reset FIFO module. Reset is asynchronous. This bit auto clears after one clock cycle.
[1]	-	Reserved.
[0]	SIG_COND_RST	1 – Reset all gyro digital signal path, accel digital signal path, and temp digital signal path. This bit also clears all the sensor registers. SIG_COND_RST is a pulse of one clk8M wide.

9.41 REGISTER 107 – POWER MANAGEMENT 1

Register Name: PWR_MGMT_1

Register Type: USR/CFG

Register Address: 107 (Decimal); 6B (Hex)

BIT	NAME	FUNCTION																		
[7]	DEVICE_RESET	1 – Reset the internal registers and restores the default settings. The bit automatically clears to 0 once the reset is done.																		
[6]	SLEEP	1 – The chip is set to sleep mode. Note: The default value is 1; the chip comes up in Sleep mode																		
[5]	ACCEL_CYCLE	When set to 1, and SLEEP and STANDBY are not set to 1, the chip will cycle between sleep and taking a single accelerometer sample at a rate determined by SMPLRT_DIV Note: When all accelerometer axes are disabled via PWR_MGMT_2 register bits and cycle is enabled, the chip will wake up at the rate determined by the respective registers above, but will not take any samples.																		
[4]	GYRO_STANDBY	When set, the gyro drive and pll circuitry are enabled, but the sense paths are disabled. This is a low power mode that allows quick enabling of the gyros.																		
[3]	TEMP_DIS	When set to 1, this bit disables the temperature sensor.																		
[2:0]	CLKSEL[2:0]	<table border="1"> <thead> <tr> <th>Code</th> <th>Clock Source</th> </tr> </thead> <tbody> <tr> <td>0</td> <td>Internal 20 MHz oscillator</td> </tr> <tr> <td>1</td> <td>Auto selects the best available clock source – PLL if ready, else use the Internal oscillator</td> </tr> <tr> <td>2</td> <td>Auto selects the best available clock source – PLL if ready, else use the Internal oscillator</td> </tr> <tr> <td>3</td> <td>Auto selects the best available clock source – PLL if ready, else use the Internal oscillator</td> </tr> <tr> <td>4</td> <td>Auto selects the best available clock source – PLL if ready, else use the Internal oscillator</td> </tr> <tr> <td>5</td> <td>Auto selects the best available clock source – PLL if ready, else use the Internal oscillator</td> </tr> <tr> <td>6</td> <td>Internal 20 MHz oscillator</td> </tr> <tr> <td>7</td> <td>Stops the clock and keeps timing generator in reset</td> </tr> </tbody> </table>	Code	Clock Source	0	Internal 20 MHz oscillator	1	Auto selects the best available clock source – PLL if ready, else use the Internal oscillator	2	Auto selects the best available clock source – PLL if ready, else use the Internal oscillator	3	Auto selects the best available clock source – PLL if ready, else use the Internal oscillator	4	Auto selects the best available clock source – PLL if ready, else use the Internal oscillator	5	Auto selects the best available clock source – PLL if ready, else use the Internal oscillator	6	Internal 20 MHz oscillator	7	Stops the clock and keeps timing generator in reset
Code	Clock Source																			
0	Internal 20 MHz oscillator																			
1	Auto selects the best available clock source – PLL if ready, else use the Internal oscillator																			
2	Auto selects the best available clock source – PLL if ready, else use the Internal oscillator																			
3	Auto selects the best available clock source – PLL if ready, else use the Internal oscillator																			
4	Auto selects the best available clock source – PLL if ready, else use the Internal oscillator																			
5	Auto selects the best available clock source – PLL if ready, else use the Internal oscillator																			
6	Internal 20 MHz oscillator																			
7	Stops the clock and keeps timing generator in reset																			

9.42 REGISTER 108 – POWER MANAGEMENT 2

Register Name: PWR_MGMT_2

Register Type: USR/CFG

Register Address: 108 (Decimal); 6C (Hex)

BIT	NAME	FUNCTION
[7]	LP_DIS	Low power disable bit. When cleared the system will enter sleep when gyro is disabled and accel is off while duty cycling.
[6]	DMP_LP_DIS	When cleared DMP will execute in low power accel mode. When set DMP will not execute in low power accel mode.
[5]	DISABLE_XA	1 – X accelerometer is disabled. 0 – X accelerometer is on.
[4]	DISABLE_YA	1 – Y accelerometer is disabled. 0 – Y accelerometer is on.
[3]	DISABLE_ZA	1 – Z accelerometer is disabled. 0 – Z accelerometer is on.
[2]	DISABLE_XG	1 – X gyro is disabled. 0 – X gyro is on.
[1]	DISABLE_YG	1 – Y gyro is disabled. 0 – Y gyro is on.
[0]	DISABLE_ZG	1 – Z gyro is disabled. 0 – Z gyro is on.

9.43 REGISTER 114 – FIFO COUNT REGISTERS

Register Name: FIFO_COUNTH

Register Type: USR/CFG

Register Address: 114 (Decimal); 72 (Hex)

BIT	NAME	FUNCTION
[7:5]	NOT IMPLEMENTED	Hard coded to '000'.
[4:0]	FIFO_COUNTH[12:8]	High Bits, count indicates the number of written bytes in the FIFO. Reading this byte latches the data for both FIFO_COUNTH, and FIFO_COUNTL.

9.44 REGISTER 115 – FIFO COUNT REGISTERS

Register Name: FIFO_COUNTL

Register Type: USR/CFG

Register Address: 115 (Decimal); 73 (Hex)

BIT	NAME	FUNCTION
[7:0]	FIFO_COUNTL[7:0]	Low Bits, count indicates the number of written bytes in the FIFO. NOTE: Must read FIFO_COUNTH to latch new data for both FIFO_COUNTH and FIFO_COUNTL.

9.45 REGISTER 116 – FIFO READ WRITE

Register Name: FIFO_R_W

Register Type: USR/CFG

Register Address: 116 (Decimal); 74 (Hex)

BIT	NAME	FUNCTION
[7:0]	FIFO_R_W[7:0]	Read/Write command provides Read or Write operation for the FIFO.

Description:

This register is used to read and write data from the FIFO buffer.

Data is written to the FIFO in order of register number (from lowest to highest). If all the FIFO enable flags (see below) are enabled, the contents of registers 59 through 72 will be written in order at the Sample Rate.

The contents of the sensor data registers (Registers 59 to 72) are written into the FIFO buffer when their corresponding FIFO enable flags are set to 1 in FIFO_EN (Register 35).

If the FIFO buffer has overflowed, the status bit *FIFO_OFLOW_INT* is automatically set to 1. This bit is located in INT_STATUS (Register 58). When the FIFO buffer has overflowed, the oldest data will be lost and new data will be written to the FIFO unless register 26 CONFIG, bit[6] FIFO_MODE = 1.

If the FIFO buffer is empty, reading register FIFO_DATA will return a unique value of 0xFF until new data is available. Normal data is precluded from ever indicating 0xFF, so 0xFF gives a trustworthy indication of FIFO empty.

9.46 REGISTER 117 – WHO AM I

Register Name: WHOAMI

Register Type: USR/CFG

Register Address: 117 (Decimal); 75 (Hex)

BIT	NAME	FUNCTION
[7:0]	WHOAMI	Register to indicate to user which device is being accessed.

This register is used to verify the identity of the device. The contents of *WHOAMI* is an 8-bit device ID.

9.47 REGISTER 119 – ACCELEROMETER OFFSET REGISTER

Register Name: XA_OFFS_H

Register Type: CFG

Register Address: 119 (Decimal); 77 (Hex)

BIT	NAME	FUNCTION
[7:0]	XA_OFFSH[14:7]	Upper bits of the X accelerometer offset cancellation. $\pm 16g$ Offset cancellation in all Full-Scale modes, 15 bit 0.98-mg steps.

9.48 REGISTER 120 – ACCELEROMETER OFFSET REGISTER

Register Name: XA_OFFS_L

Register Type: CFG

Register Address: 120 (Decimal); 78 (Hex)

BIT	NAME	FUNCTION
[7:1]	XA_OFFSL[6:0]	Lower bits of the X accelerometer offset cancellation. $\pm 16g$ Offset cancellation in all Full-Scale modes, 15 bit 0.98-mg steps
[0]	-	Reserved.

9.49 REGISTER 122 – ACCELEROMETER OFFSET REGISTER

Register Name: YA_OFFS_H

Register Type: CFG

Register Address: 122 (Decimal); 7A (Hex)

BIT	NAME	FUNCTION
[7:0]	YA_OFFSH[14:7]	Upper bits of the Y accelerometer offset cancellation. $\pm 16g$ Offset cancellation in all Full-Scale modes, 15 bit 0.98-mg steps.

9.50 REGISTER 123 – ACCELEROMETER OFFSET REGISTER

Register Name: YA_OFFS_L

Register Type: CFG

Register Address: 123 (Decimal); 7B (Hex)

BIT	NAME	FUNCTION
[7:1]	YA_OFFSL[6:0]	Lower bits of the Y accelerometer offset cancellation. $\pm 16g$ Offset cancellation in all Full-Scale modes, 15 bit 0.98-mg steps.
[0]	-	Reserved.

9.51 REGISTER 125 – ACCELEROMETER OFFSET REGISTER

Register Name: ZA_OFFS_H

Register Type: CFG

Register Address: 125 (Decimal); 7D (Hex)

BIT	NAME	FUNCTION
[7:0]	ZA_OFFSH[14:7]	Upper bits of the Z accelerometer offset cancellation. $\pm 16g$ Offset cancellation in all Full-Scale modes, 15 bit 0.98-mg steps.

9.52 REGISTER 126 – ACCELEROMETER OFFSET REGISTER

Register Name: ZA_OFFS_L

Register Type: CFG

Register Address: 126 (Decimal); 7E (Hex)

BIT	NAME	FUNCTION
[7:1]	ZA_OFFSL[6:0]	Lower bits of the Z accelerometer offset cancellation. $\pm 16g$ Offset cancellation in all Full-Scale modes, 15 bit 0.98-mg steps.
[0]	-	Reserved.

10 PRESSURE SENSOR – HOW TO READ

10.1 I²C OPERATION AND COMMUNICATION

All commands and memory locations of the ICM-20789 are mapped to a 16-bit address space which can be accessed via the I²C protocol.

ICM-20789	Bin.	Dec.	Hex.
I ² C Address	110'0011	99	0x63

Table 23. ICM-20789 I²C Device Address

Power-Up and Communication Start

Upon VDD reaching the power-up voltage level VPOR, the ICM-20789 enters idle state after a duration of tPU. In idle state, the ICM-20789 is ready to receive commands from the master (microcontroller).

Each transmission sequence begins with START condition (S) and ends with an (optional) STOP condition (P) as described in the I²C-bus specification. Whenever the sensor is powered up, but not performing a measurement or communicating, it automatically enters idle state for energy saving.

Measurement Commands

The ICM-20789 provides the possibility to define the sensor behavior during measurement as well as the transmission sequence of measurement results. These characteristics are defined by the appropriate measurement command (see Table 24). Each measurement command triggers both a temperature *and* a pressure measurement.

OPERATION MODE	TRANSMIT T FIRST	TRANSMIT P FIRST
Low Power (LP)	0x609C	0x401A
Normal (N)	0x6825	0x48A3
Low Noise (LN)	0x70DF	0x5059
Ultra-Low Noise (ULN)	0x7866	0x58E0

Table 24. Measurement Commands

Starting a Measurement

A measurement communication sequence consists of a START condition followed by the I²C header with the 7-bit I²C device address and a write bit (write W: '0', 8-bit word including I²C header: 0xC6). The sensor indicates the proper reception of a byte by pulling the SDA pin low (ACK bit) after the falling edge of the 8th SCL clock. Then the sensor is ready to receive a 16-bit measurement command. Again, the ICM-20789 acknowledges the proper reception of each byte with ACK condition.

With the acknowledgement of the measurement command, the ICM-20789 starts measuring pressure and temperature.

Sensor Behavior during Measurement

In general, the sensor does not respond to any I²C activity during measurement, i.e. I²C read and write headers are not acknowledged (NACK).

Readout of Measurement Results

After a measurement command has been issued and the sensor has completed the measurement, the master can read the measurement results by sending a START condition followed by an I²C read header (8-bit word including I²C header: 0xC7). The sensor will acknowledge the reception of the read header and send the measured data in the specified order to the master. The MSB of the corresponding data is always transmitted first. Temperature data is transmitted in two 8-bit words and pressure data is transmitted in four 8-bit words. Regarding the pressure data, only the first three words MMSB, MLSB and LMSB contain information about the ADC pressure value. Therefore, for retrieving the ADC pressure value, LLSB must be disregarded:

$$p_{dout} = \text{MMSB} \ll 16 \mid \text{MLSB} \ll 8 \mid \text{LMSB}.$$

Two bytes of data are always followed by one byte CRC checksum, for calculation see the Checksum Calculation section. Each byte must be acknowledged by the microcontroller with an ACK condition for the sensor to continue sending data. If the ICM-20789 does not receive an ACK from the master after any byte of data, it will not continue sending data.

Whether the sensor sends out pressure or temperature data first depends on the measurement command that was sent to the sensor to initiate the measurement. The I²C master can abort the read transfer with a NACK condition after any data byte if it is not interested in subsequent data, e.g. the CRC byte or the second measurement result, in order to save time.

Soft Reset

The ICM-20789 provides a soft reset mechanism that forces the system into a well-defined state without removing the power supply. If the system is in idle state (i.e. if no measurement is in progress) the soft reset command will be accepted by ICM-20789. This triggers the sensor to reset all internal state machines and reload calibration data from the memory.

Command	Hex Code	Binary Code
Soft reset	0x805D	1000'0000'0101'1101

Table 25. Soft Reset Command

Read-out of ID Register

The ICM-20789 has an ID register which contains a specific product code. The read-out of the ID register can be used to verify the presence of the sensor and proper communication. The command to read the ID register is shown in Table 21.

Command	Hex Code	Binary Code
Read ID Register	0xEFC8	1110'1111'1100'1000

Table 26. Read-Out Command of ID Register

It needs to be sent to the ICM-20789 after an I²C write header. After the ICM-20789 has acknowledged the proper reception of the command, the master can send an I²C read header and the ICM-20789 will submit the 16-bit ID followed by 8 bits of CRC. The structure of the ID is described in Table 22.

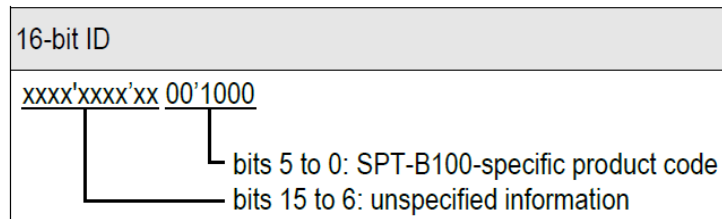

Table 27. Structure of the 16-bit ID

Bits 15:6 of the ID contain unspecified information (marked as “x”), which may vary from sensor to sensor, while bits 5:0 contain the ICM-20789-specific product code.

Checksum Calculation

The 8-bit CRC checksum transmitted after each data word is generated by a CRC algorithm with the properties displayed in Table 23. The CRC covers the contents of the two previously transmitted data bytes.

Property	Value
Name	CRC-8
Width	8 bits
Polynomial	0x31 ($x^8 + x^5 + x^4 + 1$)
Initialization	0xFF
Reflect input	false
Reflect output	false
Final XOR	0x00
Examples	CRC(0x00) = 0xAC CRC(0xBEEF) = 0x92

Table 28. ICM-20789 I²C CRC Properties

Conversion of Signal Output

Pressure measurement data is always transferred as 4 8-bit words; temperature measurement data is always transferred as two 8-bit words. Please see Readout of Measurement Results (Page 44) for more details.

Temperature measurement values t_dout are linearized by the ICM-20789 and must be calculated to °C by the user via the following formula:

$$T = -45^{\circ}\text{C} + (175^{\circ}\text{C} / 2^{16}) \times t_dout$$

For retrieving physical pressure values in Pa the following conversion formula has to be used:

$$P = A + B / (C + p_{dout})$$

where p_{dout} is the sensor's raw pressure output. The converted output is compensated for temperature effects via the temperature dependent functions A , B and C . Besides the raw temperature output t_dout , the calculation of A , B and C requires to access calibration parameters OTP0, OTP1, OTP2, OTP3 stored in the OTP of the sensor.

Full sample code for calculating physical pressure values is given in the Sample Code section. The general workflow of the conversion is done by:

- 1) Import class `Invensense_pressure_conversion`
- 2) Read out values OTP0, ..., OTP3 and save to $c1$, ..., $c4$
- 3) Create object *name* for an individual sensor with parameter values $c1$, ..., $c4$
`name = Invensense_pressure_conversion ([c1,c2,c3,c4])`
- 4) Get raw pressure p_dout and temperature t_dout data from the sensor as described in chapter Readout of Measurement Results.
- 5) Call function `get_pressure`: `name.get_pressure(p_dout, t_dout)`

The Sample Code section gives an example of this workflow.

Read-out of calibration parameters

For converting raw pressure data to physical values, four calibration parameters have to be retrieved from the OTP of the sensor.

Set up of OTP read:

- 1) Send I²C write header 0xC6
- 2) Send command 0xC595 (move pointer in address register)
- 3) Send address parameter together with its CRC 0x00669C

Steps 1) – 3) can be done on many platforms by a single I²C write of the value 0xC59500669C.

Read out parameters:

Repeat the following procedure 4 times:

- a. Send I²C write header 0xC6
- b. Send command 0xC7F7 (incremental read-out of OTP)
- c. Send I²C read header 0xC7
- d. Read 3Byte (2Byte of data and 1Byte of CRC)
- e. Decode data as 16-bit big endian signed integer and store result into n-th calibration parameter c_n .

Steps a) to d) can be done on many platforms by a single write 0xC7F7 to the chip address followed by a single read of 3 Byte from the chip slave device address.

Sample Pseudo Code: conversion formula (exemplary python syntax)

```
class Invensense_pressur_Conversion:
    """ Class for conversion of the pressure and temperature output of the Invensense sensor"""

    def __init__(self, sensor_constants):
        """ Initialize customer formula

        Arguments:
        sensor_constants -- list of 4 integers: [c1, c2, c3, c4]
        """
        self.sensor_constants = sensor_constants

    # configuration for Pressure Samples
    self.p_Pa_calib = [45000.0, 80000.0, 105000.0]
    self.LUT_lower = 3.5 * (2**20)
    self.LUT_upper = 11.5 * (2**20)
    self.quadr_factor = 1 / 16777216.0
    self.offst_factor = 2048.0
```

```

def calculate_conversion_constants(self, p_Pa, p_LUT):
    """ calculate temperature dependent constants

    Arguments:
    p_Pa -- List of 3 values corresponding to applied pressure in Pa
    p_LUT -- List of 3 values corresponding to the measured p_LUT values at the applied pressures.
    """

    C = (p_LUT[0] * p_LUT[1] * (p_Pa[0] - p_Pa[1]) +
         p_LUT[1] * p_LUT[2] * (p_Pa[1] - p_Pa[2]) +
         p_LUT[2] * p_LUT[0] * (p_Pa[2] - p_Pa[0])) / \
        (p_LUT[2] * (p_Pa[0] - p_Pa[1]) +
         p_LUT[0] * (p_Pa[1] - p_Pa[2]) +
         p_LUT[1] * (p_Pa[2] - p_Pa[0]))
    A = (p_Pa[0] * p_LUT[0] - p_Pa[1] * p_LUT[1] - (p_Pa[1] - p_Pa[0]) * C) / (p_LUT[0] - p_LUT[1])
    B = (p_Pa[0] - A) * (p_LUT[0] + C)

    return [A, B, C]

def get_pressure(self, p_LSB, T_LSB):
    """ Convert an output from a calibrated sensor to a pressure in Pa.

    Arguments:
    p_LSB -- Raw pressure data from sensor
    T_LSB -- Raw temperature data from sensor
    """
    t = T_LSB - 32768.0
    s1 = self.LUT_lower + float(self.sensor_constants[0] * t * t) * self.quadr_factor
    s2 = self.offst_factor * self.sensor_constants[3] + float(self.sensor_constants[1] * t * t) * self.quadr_factor
    s3 = self.LUT_upper + float(self.sensor_constants[2] * t * t) * self.quadr_factor
    A, B, C = self.calculate_conversion_constants(self.p_Pa_calib, [s1, s2, s3])
    return A + B / (C + p_LSB)
[end of the pseudocode]

```

Sample code: using conversion formula (exemplary python syntax)

```
def read_otp_from_i2c():
    # TODO: implement read from I2C
    # refer to data sheet for I2C commands to read OTP
    return 1000, 2000, 3000, 4000

def read_raw_pressure_temp_from_i2c():
    # TODO: implement read from I2C
    # refer to data sheet for I2C commands to read pressure and temperature
    return 8000000, 32000

# Sample code to read
from Invensense_pressure_conversion import Invensense_pressure_conversion

# -- initialization
c1, c2, c3, c4 = read_otp_from_i2c()
conversion = Invensense_pressure_conversion([c1, c2, c3, c4])

# -- read raw pressure and temp data, calculate pressure
p, T = read_raw_pressure_temp_from_i2c()
pressure = conversion.get_pressure(p, T)
print 'Pressure: %f' % pressure

[end of the pseudocode]
```

Communication Data Sequences

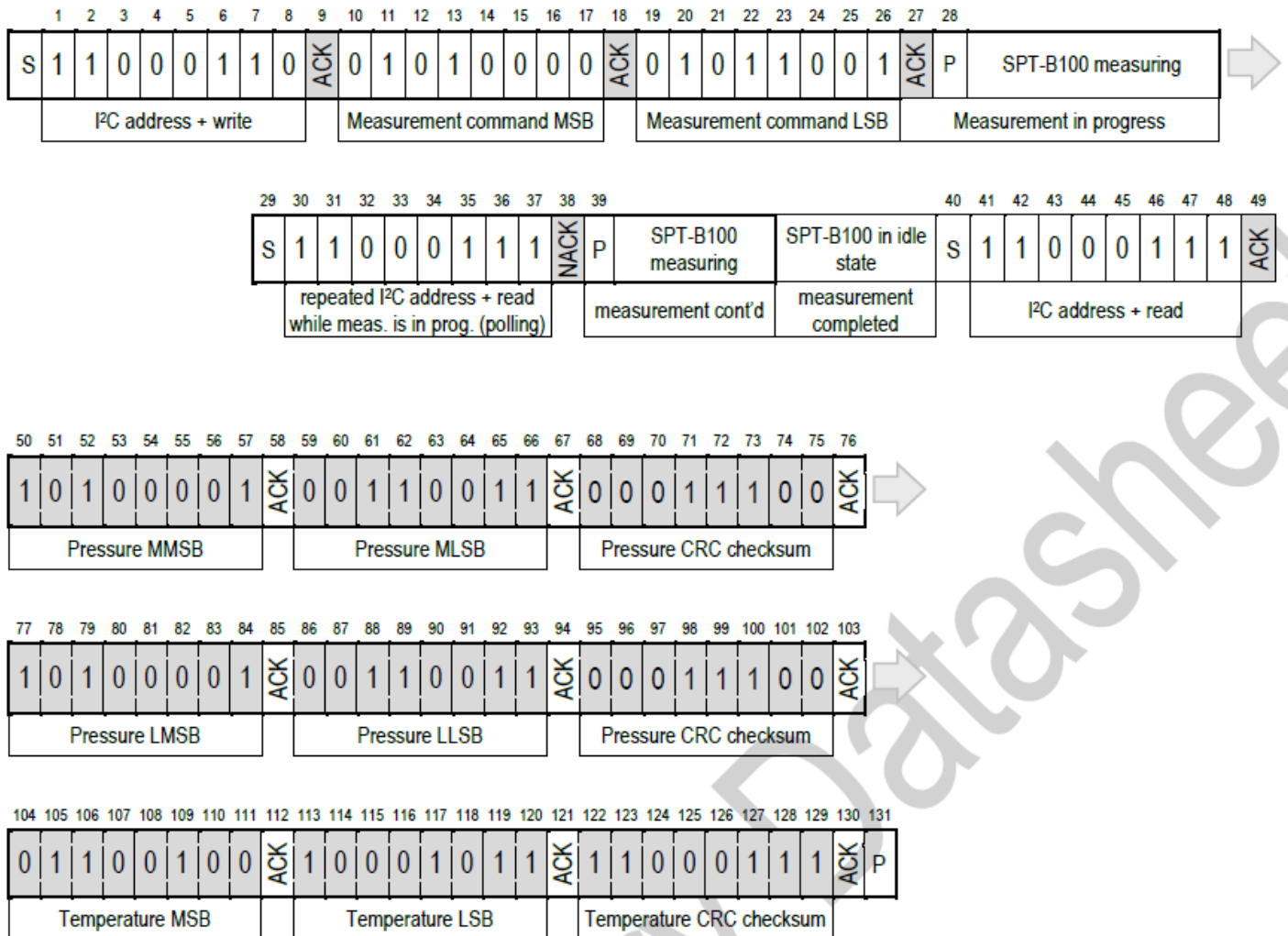

Figure 15. Communication Sequence for starting a measurement and reading measurement results

11 ASSEMBLY

This section provides general guidelines for assembling TDK-InvenSense Micro Electro-Mechanical Systems (MEMS) gyros packaged in LGA package.

11.1 ORIENTATION OF AXES

The diagram below shows the orientation of the axes of sensitivity and the polarity of rotation. Note the pin 1 identifier (●) in the figure.

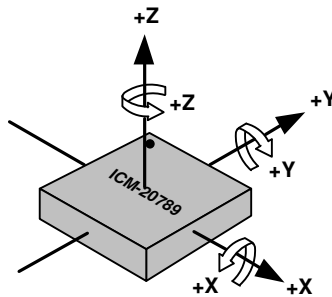

Figure 16. Orientation of Axes of Sensitivity and Polarity of Rotation

11.2 IMPLEMENTATION AND USAGE RECOMMENDATIONS

Soldering

When soldering, use the standard soldering profile IPC/JEDEC J-STD-020 with peak temperatures of 260°C. ICM-20789 may exhibit a pressure offset after soldering, some settling time may be required depending on soldering properties, PCB properties, and ambient conditions.

The ICM-20789 is an open cavity package, it is mandatory to use no-clean solder paste and no board wash should be applied. The ICM-20789 should be limited to a single reflow and no rework is recommended.

Chemical Exposure and Sensor Protection

The ICM-20789 is an open cavity package and therefore should not be exposed to particulates or liquids. If any type of protective coating must be applied to the circuit board, the sensor must be protected during the coating process.

11.3 PACKAGE DIMENSIONS

24 Lead LGA (4 mm x 4 mm x 1.365 mm) NiPdAu Lead-frame finish

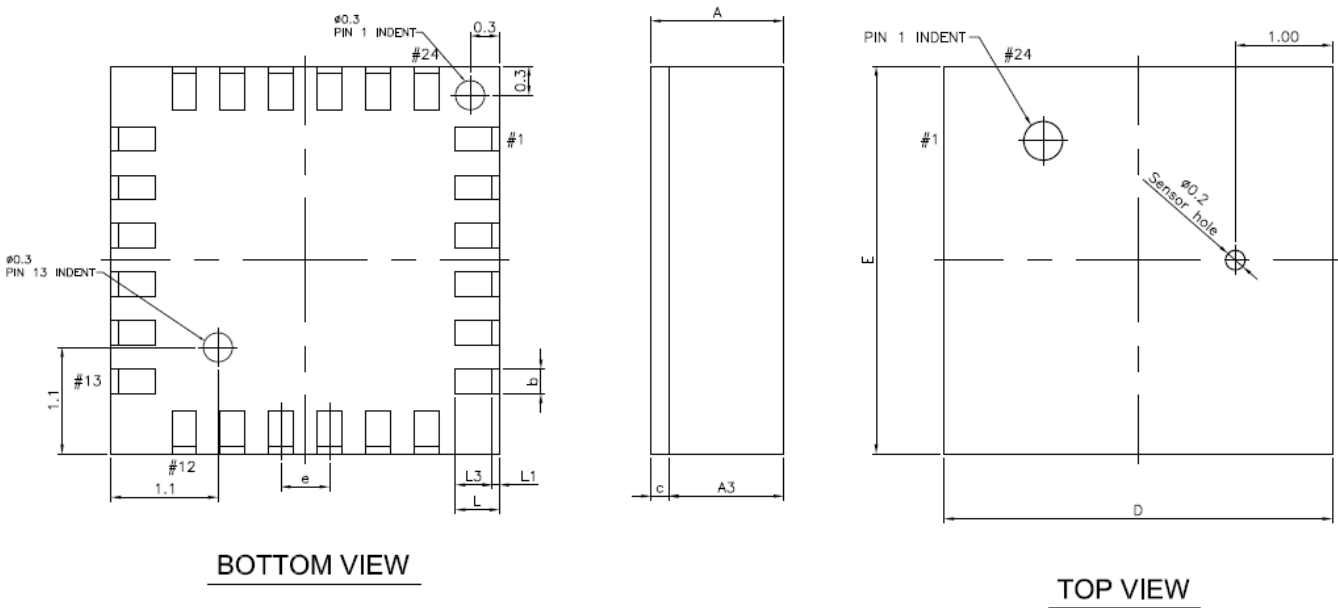

Figure 17. Package Dimensions

SYMBOLS	DIMENSIONS IN MILLIMETERS		
	MIN	NOM	MAX
A	1.265	1.365	1.465
A3	---	1.185 REF.	---
b	0.20	0.25	0.30
c	---	0.18 REF.	---
D	3.90	4.00	4.10
E	3.90	4.00	4.10
e	---	0.50	---
L	0.35	0.45	0.55
L1	0.025	0.075	0.125
L3	0.325	0.375	0.425

Table 29. Package Dimensions Table

Figure 18 shows the recommended PCB land pattern for ICM-20789.

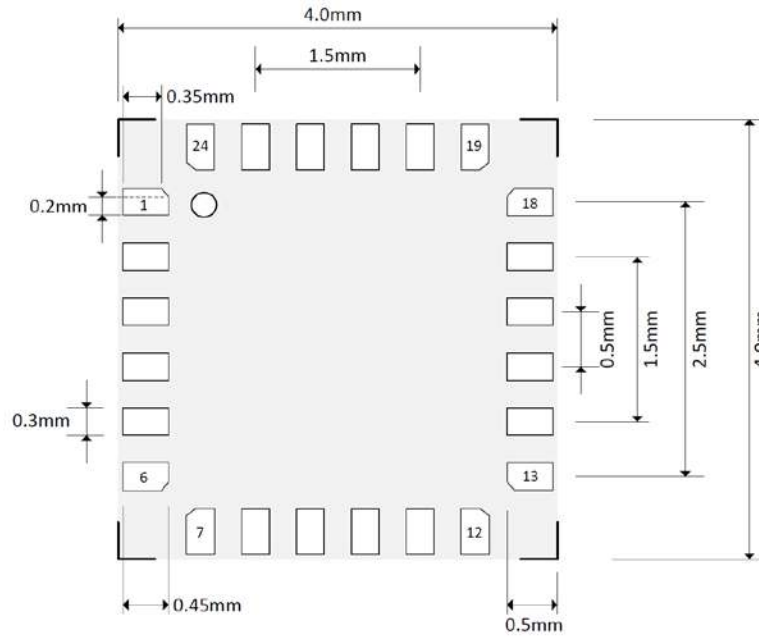

Figure 18. ICM-20789 recommended PCB land pattern

12 PART NUMBER PACKAGE MARKING

The part number package marking for ICM-20789 devices is summarized below:

PART NUMBER	PART NUMBER PACKAGE MARKING
ICM-20789	IC2789

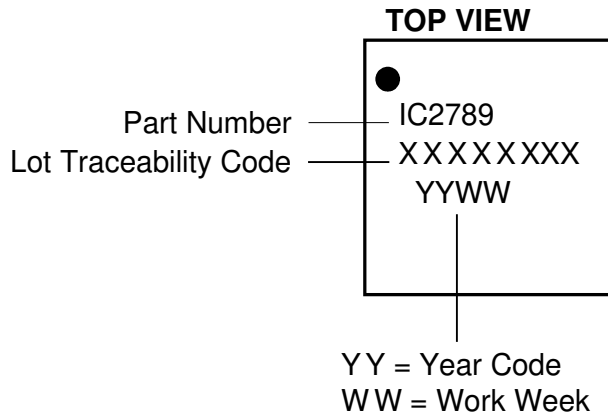

Figure 19. Part Number Package Marking

13 ORDERING GUIDE

PART	TEMP RANGE	PACKAGE	QUANTITY	PACKAGING
ICM-20789†	-40°C to +85°C	24-Pin LGA	3,000	13" Tape and Reel

†Denotes RoHS and Green-Compliant Package

14 REFERENCE

Please refer to “InvenSense MEMS Handling Application Note (AN-IVS-0002A-00)” for the following information:

- Manufacturing Recommendations
 - Assembly Guidelines and Recommendations
 - PCB Design Guidelines and Recommendations
 - MEMS Handling Instructions
 - ESD Considerations
 - Reflow Specification
 - Storage Specifications
 - Package Marking Specification
 - Tape & Reel Specification
 - Reel & Pizza Box Label
 - Packaging
 - Representative Shipping Carton Label
- Compliance
 - Environmental Compliance
 - DRC Compliance
 - Compliance Declaration Disclaimer

15 REVISION HISTORY

REVISION DATE	REVISION	DESCRIPTION
06/05/17	1.0	Initial Release
08/28/2017	1.1	Updated part marking
10/04/17	1.2	Updated performance specifications, added handling instructions
10/31/17	1.3	Updated Ordering Guide, Clarified Pin Connections as NC, GND, or VDD

This information furnished by InvenSense, Inc. ("InvenSense") is believed to be accurate and reliable. However, no responsibility is assumed by InvenSense for its use, or for any infringements of patents or other rights of third parties that may result from its use. Specifications are subject to change without notice. InvenSense reserves the right to make changes to this product, including its circuits and software, in order to improve its design and/or performance, without prior notice. InvenSense makes no warranties, neither expressed nor implied, regarding the information and specifications contained in this document. InvenSense assumes no responsibility for any claims or damages arising from information contained in this document, or from the use of products and services detailed therein. This includes, but is not limited to, claims or damages based on the infringement of patents, copyrights, mask work and/or other intellectual property rights.

Certain intellectual property owned by InvenSense and described in this document is patent protected. No license is granted by implication or otherwise under any patent or patent rights of InvenSense. This publication supersedes and replaces all information previously supplied. Trademarks that are registered trademarks are the property of their respective companies. InvenSense sensors should not be used or sold in the development, storage, production or utilization of any conventional or mass-destructive weapons or for any other weapons or life threatening applications, as well as in any other life critical applications such as medical equipment, transportation, aerospace and nuclear instruments, undersea equipment, power plant equipment, disaster prevention and crime prevention equipment.

©2017 InvenSense. All rights reserved. InvenSense, MotionTracking, MotionProcessing, MotionProcessor, MotionFusion, MotionApps, DMP, AAR, and the InvenSense logo are trademarks of InvenSense, Inc. The TDK logo is a trademark of TDK Corporation. Other company and product names may be trademarks of the respective companies with which they are associated.