

LOC		DIST		REVISIONS			
REV	DATE	DESCRIPTION	DATE	BY	APPV		
AJ	16						
A1		REVISED PER ECR-05-009324	30AUG05	BM	JL		
A2		REVISED PER ECO-09-024927	10NOV09	KK	AEG		

- ⚠ USE CRIMP TOOL: 354940-1
- 2. PANEL THICKNESS = 5.08 [.200] MAX
- 3. USE INSTRUCTION SHEET 408-4048
- 4. CAPACITANCE = 9400 PF ± 10% TOTAL
VOLTAGE = 500 VDC
- ⚠ OBSOLETE PARTS: OBSOLETE CIS STREAMLINING
PER D.RENAUD/D.SINISI

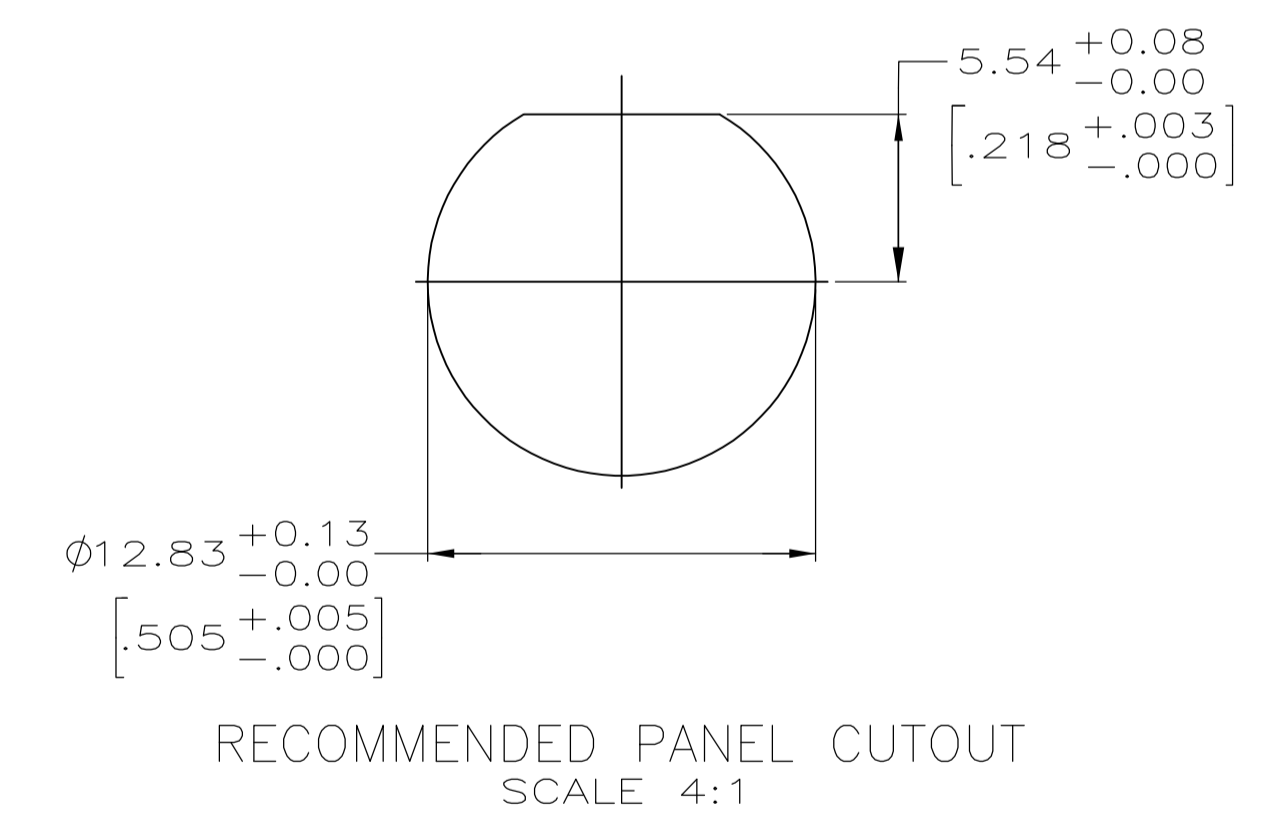
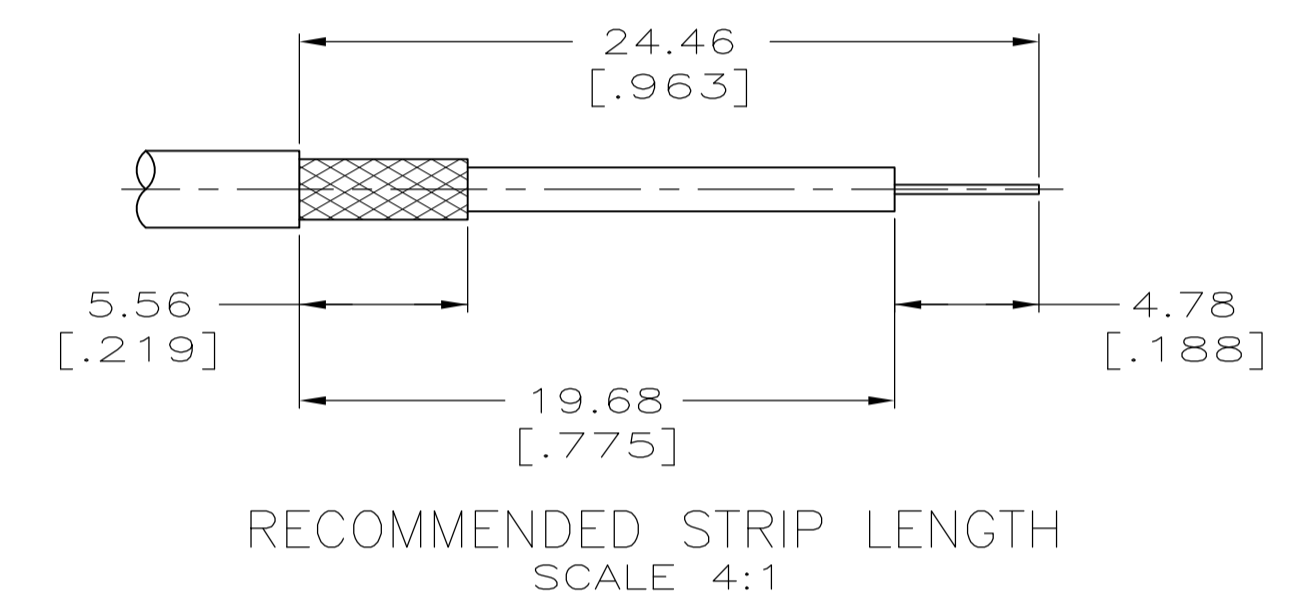
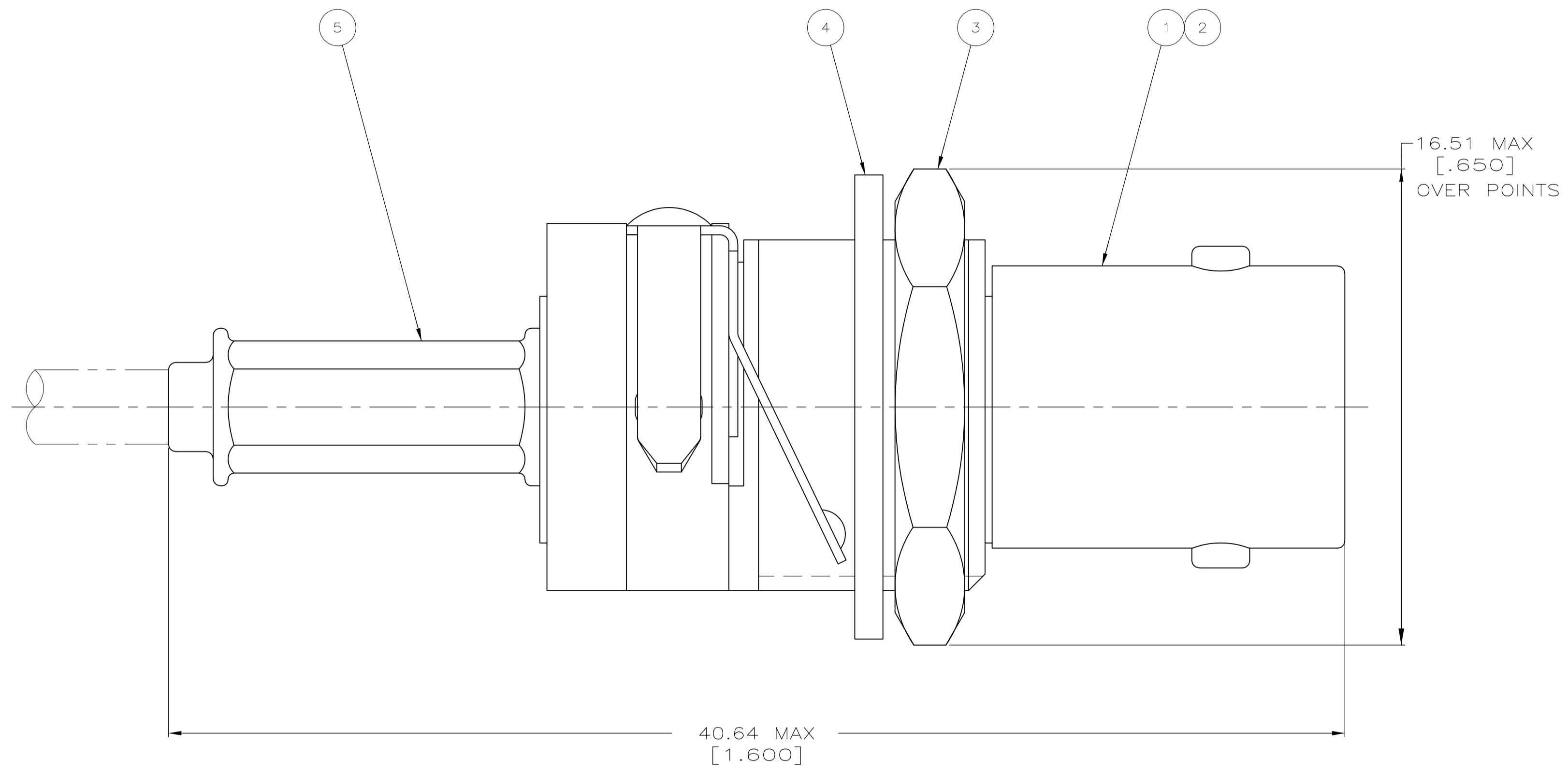

OBSOLETE ⚠	RG-174/U, 188/U, 316/U	4.52 [.178]	1.73 [.068]	58436-3	227194-5	9-413658-0	1-329632-2	1-329631-2	1-413774-5	414757-3	5414758-3
	RG-174/U, 188/U, 316/U	4.52 [.178]	1.73 [.068]	58436-3	227194-5	9-413658-0	1-329632-2	1-329631-2	1-413774-5	414757-2	5414758-2
	RG-58/U, 58A/U, 58B/U, 58C/U	5.41 [.213]	1.73 [.068]	58436-1	-	9-221132-0	1-329632-2	1-329631-2	413774-5	414757-1	5414758-1
	FOR USE WITH CABLE	FERRULE	CENTER CONTACT	DIE SET ⚠	⑥ SPACER QTY=1	⑤ FERRULE QTY=1	④ LOCK WASHER QTY=1	③ JAM NUT QTY=1	② CONTACT QTY=1	① JACK ASSEMBLY QTY=1	PART NUMBER
		HEX CRIMP HEIGHTS									

THIS DRAWING IS A CONTROLLED DOCUMENT.

DIMENSIONS: mm (INCHES)	TOLERANCES UNLESS OTHERWISE SPECIFIED:	DRAWN: J. HAVENER	DATE: 26APR2005	APPROVED: J. LIPPERT	DATE: 26APR2005	NAME: J. LIPPERT	PRODUCT SPEC: 108-1490	APPLICATION SPEC: -	SIZE: A1	CAGE CODE: 00779	DRAWING NO: 5414758	RESTRICTED TO: -
MATERIAL: -	FINISH: -	WEIGHT: -	CUSTOMER DRAWING	SCALE: 8:1	SHEET: 1 OF 1	REV: A2						

Tyco Electronics Corporation
Harrisburg, Pa 17105-3608

JACK, BULKHEAD, DECOUPLER, 50 OHM, HEX CRIMP, BNC