

REV.	DESCRIPTION	DATE	APPROVED
C	Engineering Update w/o Changes	02/13/04	M. C.
D	Updated S Dimension	11/26/07	M. C.
E	Updated 14-NL Material to 94V-0	09/11/12	T. Y.
F	Added Notes 3, 4, 5 & Color Options Sheet #2	05/16/16	J. C.

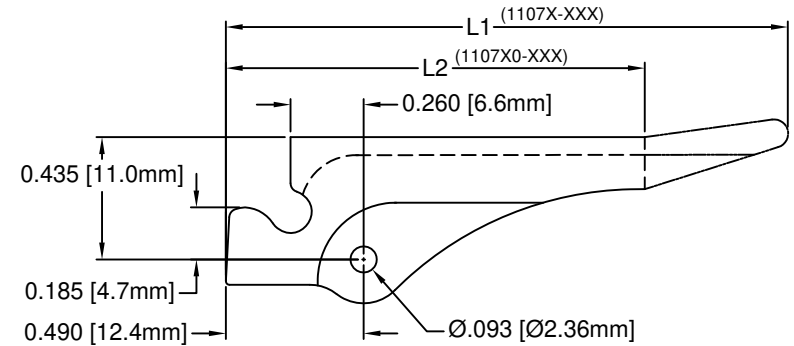

PART NO.	COLOR	S	W	L1	L2	PCB THICKNESS	ROLL PIN	DESC
1107-062 NT	NATURAL	.075 (1.9mm)	.290 (7.4mm)	2.0 (50.8mm)	-	.062 (1.6mm)	RP-250	83023-09
1107-062 XX	SEE S.#2							
11073-062 NT	NATURAL	.075 (1.9mm)	.350 (8.9mm)	2.0 (50.8mm)	-	.062 (1.6mm)	RP-312	-
11073-062 XX	SEE S.#2							
11073-093 NT	NATURAL	.100 (2.5mm)	.350 (8.9mm)	2.0 (50.8mm)	-	.093 (2.4mm)	RP-312	-
11073-093 XX	SEE S.#2							
11073-125 NT	NATURAL	.140 (3.6mm)	.350 (8.9mm)	2.0 (50.8mm)	-	.125 (3.2mm)	RP-312	83023-10
11073-125 XX	SEE S.#2							
110710-062 NT	NATURAL	.075 (1.9mm)	.290 (7.4mm)	-	1.5 (38.1mm)	.062 (1.6mm)	RP-250	83023-11
110710-062 XX	SEE S.#2							
1107310-062 NT	NATURAL	.075 (1.9mm)	.350 (8.9mm)	-	1.5 (38.1mm)	.062 (1.6mm)	RP-312	-
1107310-062 XX	SEE S.#2							
1107310-093 NT	NATURAL	.100 (2.5mm)	.350 (8.9mm)	-	1.5 (38.1mm)	.093 (2.4mm)	RP-312	-
1107310-093 XX	SEE S.#2							
1107310-125 NT	NATURAL	.140 (3.6mm)	.350 (8.9mm)	-	1.5 (38.1mm)	.125 (3.2mm)	RP-312	-
1107310-125 XX	SEE S.#2							

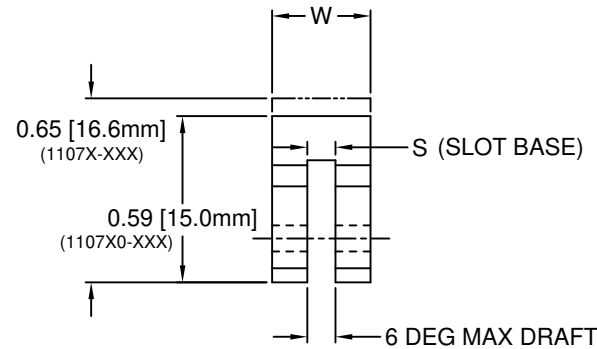
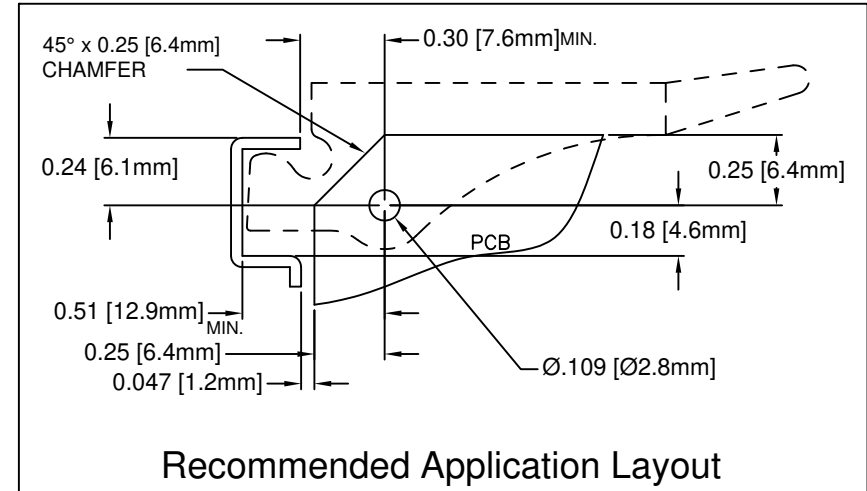

Recommended Application Layout

STANDARD TOLERANCE (UNLESS OTHERWISE SPECIFIED)		BIVAR®	
DECIMALS	ANGULAR	4 THOMAS, IRVINE, CA. 92618	
.X ± .1	X° ± 1°	TEL.: (949) 951-8808 FAX: (949) 951-3974	
.XX ± .01		TITLE: PCB INSERTER/EXTRACTOR	
.XXX ± .005		PART NO: 1107XXX-XXX XX	
DESIGNED: <b>D. Green</b>	DATE: <b>04/16/03</b>	REVISION: <b>F</b>	
CHECKED: <b>M. Chen</b>	DATE: <b>04/16/03</b>	CAGE CODE : 32559 SHEET # 1 OF 2	
CAD GENERATED DOCUMENT. DO NOT MEASURE DRAWING.			

4. PRE-ASSEMBLED ROLL PINS AVAILABLE UPON REQUEST.
3. ROLL PINS INCLUDED. PACKAGED SEPARATELY.
2. MATERIAL: NYLON 6/6, 30% GLASS, 94V-0 NATURAL.
1. GENERAL SPECIFICATIONS: BIVAR MOLDED COMPONENT SPECIFICATION BV00-E101.

OTHER AVAILABLE COLORS  
 \* SEE TABLE FOR ORDERING INFORMATION

REV.	DESCRIPTION	DATE	APPROVED
	SEE SHEET #1		

1107 - - - - -

SERIES
1107-062
11073-062
11073-093
11073-125
110710-062
1107310-062
1107310-093
1107310-125

ORDER CODE	COLOR
AA	AQUA
BK	BLACK
BE	BLUE
BN	BROWN
FG	FOREST GREEN
GY	GRAY
GN	GREEN
LE	LIME
OE	ORANGE
PK	PINK
RD	RED
VT	VIOLET
YW	YELLOW

5. PARTS ARE DYED TO COLOR UPON REQUEST.

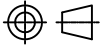
STANDARD TOLERANCE ( UNLESS OTHERWISE SPECIFIED ) DECIMALS                      ANGULAR		 4 THOMAS, IRVINE, CA. 92618 TEL: (949) 951-8808    FAX: (949) 951-3974	
			
DESIGNED: <b>D. Green</b>	DATE: <b>04/16/03</b>	<b>TITLE:</b> PCB INSERTER/EXTRACTOR	
CHECKED: <b>M. Chen</b>	DATE: <b>04/16/03</b>	<b>PART NO:</b> 1107XXX-XXX XX	REVISION: <b>F</b>
		<b>CAGE CODE : 32559</b>	<b>SHEET # 2 OF 2</b>
CAD GENERATED DOCUMENT. DO NOT MEASURE DRAWING.			