

| PART NUMBER | REV | FIRST USED |
|-------------|-----|------------|
| 1852173-1 | B | 854400-1 |
| 1852173-2 | B | 565435-5 |

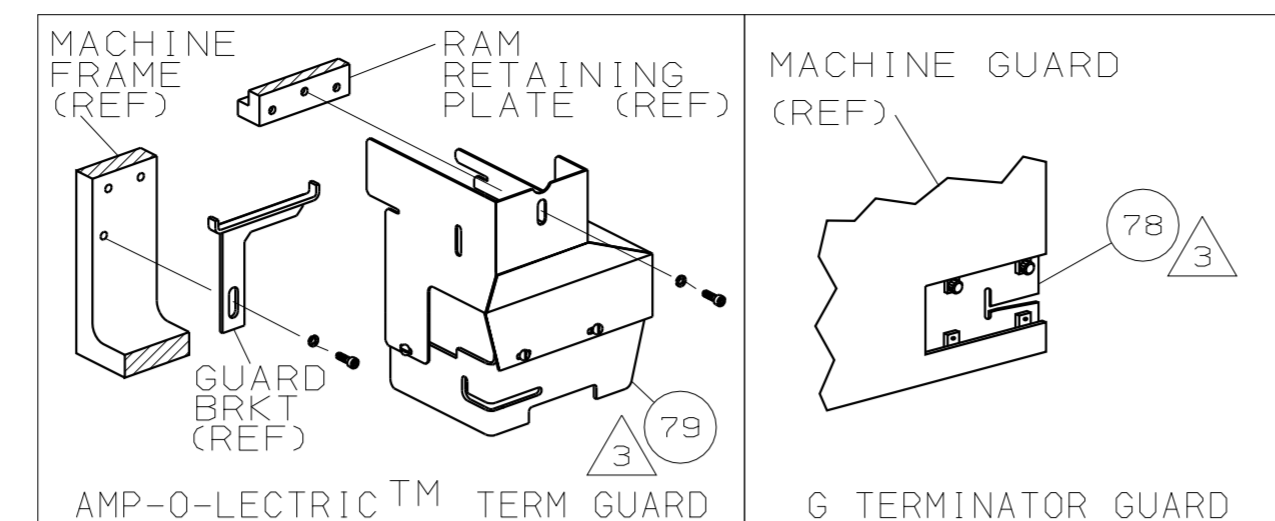

| TYCO TERM PN | | MFG TERM PN | | ESCUBEDO TERMINAL | | | AMP CRIMP SPECS | |
|--------------|---------------------------|---------------------|--|-------------------|---------------|------|------------------------|--|
| PAD LTR | CRIMP HEIGHT | WIRE SIZE | | CRIMP | SIZE | TYPE | RANGE | |
| A | .060 ±.002 [1.52 ±0.05mm] | 1.0mm ² | | WIRE | .090 [2.29mm] | F | 0.5-1.0mm ² | |
| B | .056 ±.002 [1.42 ±0.05mm] | 0.75mm ² | | INSUL | .130 [3.30mm] | F | Ø1.8-2.5mm | |
| C | .052 ±.002 [1.32 ±0.05mm] | 0.5mm ² | | | | | | |
| D | NOT | USED | | | | | | |

| -1 | | LEADMAKER & BENCH MODEL G | | MECH POST FEED | | |
|----|---|---------------------------|---|----------------|---------------------|----|
| -2 | | BENCH MODEL K | | MECH POST FEED | | |
| 1 | 1 | - | A | 22594-8 | NUT, HEX | 70 |
| 1 | 1 | - | B | 240628-1 | PLATE, ADJ | 69 |
| 1 | 1 | - | B | 240626-1 | SHAFT, PIVOT | 68 |
| 1 | 1 | - | B | 240633-1 | BUSHING | 67 |
| 1 | 1 | - | A | 455680-2 | LEVER, INTERMEDIATE | 66 |
| 1 | 1 | - | B | 240629-1 | BLOCK, PIVOT | 65 |
| 1 | 1 | - | A | 1804311-1 | SCR, ADJ | 64 |
| 1 | 1 | - | B | 240659-3 | PIN, CAM ROLLER | 63 |
| 1 | 1 | - | B | 240658-1 | CAM, ROLLER | 62 |
| 1 | 1 | - | B | 454398-1 | ROD, FEED | 61 |

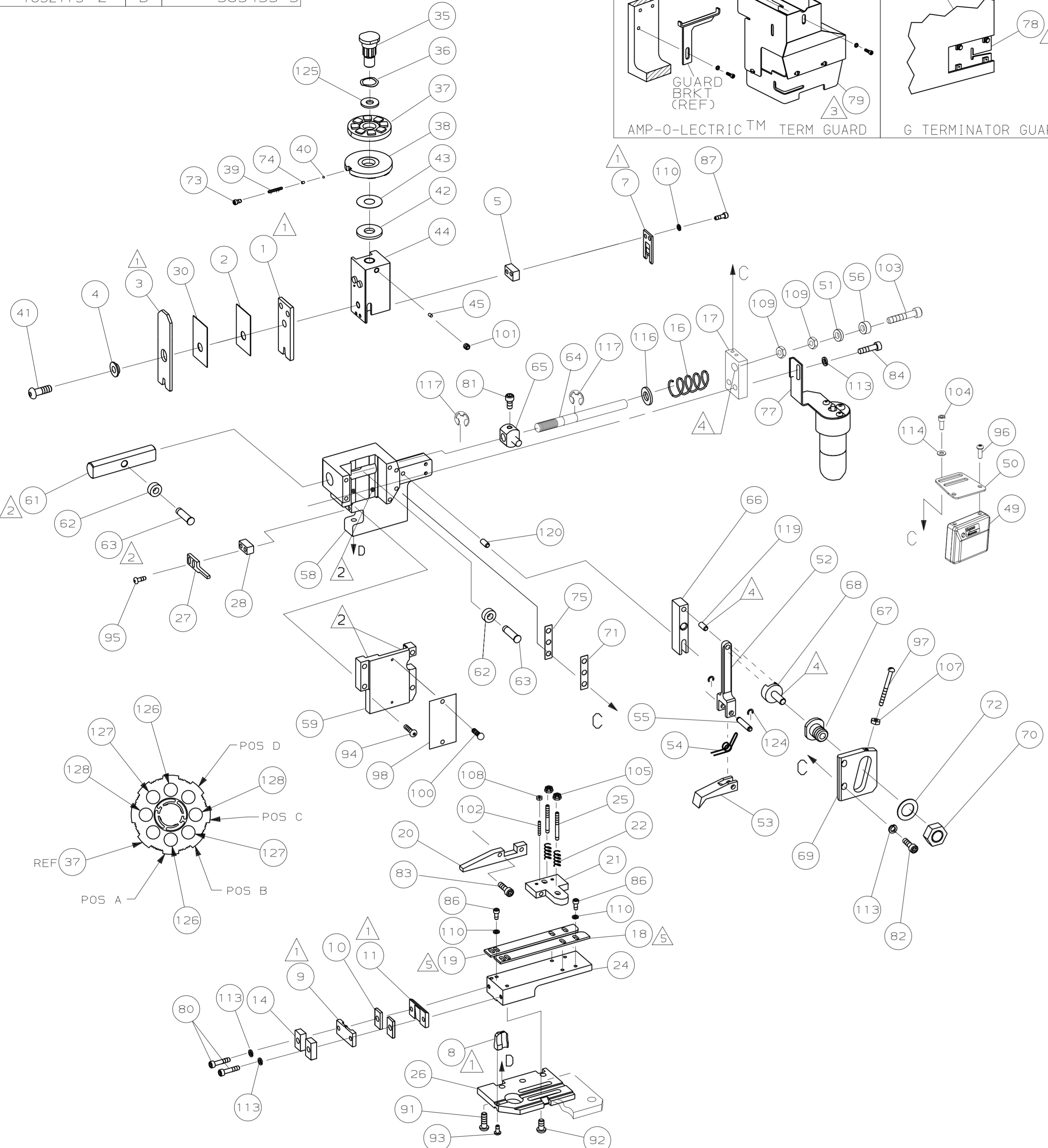

| QTY | RECD | PER | ASSY | PART NO | DESCRIPTION | ITEM NO |
|-----|------|-----|------|------------|---------------------------------------|---------|
| 2 | 2 | - | C | 2-354779-7 | PIN, WIRE DISC (.3125)C | 129 |
| 2 | 2 | - | C | 1-354779-8 | PIN, WIRE DISC (.3080)B | 127 |
| 2 | 2 | - | C | 354779-9 | PIN, WIRE DISC (.3035)A | 126 |
| 1 | 1 | - | A | 986950-1 | WASHER, FLAT PRECISION | 125 |
| 2 | 2 | - | A | 21045-3 | RING, RET "C" (Ø.187)FD PIN | 124 |
| | | | | | | 123 |
| | | | | | | 122 |
| | | | | | | 121 |
| 1 | 1 | - | A | 1-21030-7 | PIN, DOWEL (Ø.187x1.50)HSG | 120 |
| 1 | 1 | - | A | 1-21030-1 | PIN, DOWEL (Ø.187x.50)LEVER | 119 |
| | | | | | | 118 |
| 2 | 2 | - | A | 1-21046-6 | RING, RETAINING, EXT (5/16)FD ADJ ROD | 117 |
| 1 | 1 | - | A | 21899-4 | WASHER, FLAT (Ø5/16) SCR ADJ | 116 |
| | | | | | | 115 |
| 2 | 2 | - | A | 18028-2 | WASHER, FLAT (M4) COUNTER | 114 |
| 6 | 6 | - | A | 21024-5 | WASHER, LOCK (NO. 10) SHEAR PL | 113 |
| | | | | | | 112 |
| | | | | | | 111 |
| 6 | 6 | - | A | 21024-4 | WASHER, LOCK (NO. 8) SHEAR BL | 110 |
| 2 | 2 | - | A | 22593-1 | NUT, HEX (1/4-20) MAGNET | 109 |
| 2 | 2 | - | A | 21018-4 | NUT, HEX (4-40) DRAG | 108 |
| 1 | 1 | - | A | 21018-5 | NUT, HEX (6-32)FD ADJ PL | 107 |
| | | | | | | 106 |
| 2 | 2 | - | A | 21022-2 | NUT, HEX 5L (8-32)DRAG STUD | 105 |
| 2 | 2 | - | A | 9-21000-9 | SCR, SHC (8-32x.44) COUNTER | 104 |
| 1 | 1 | - | A | 3-21081-3 | SCR, SHC (1/4-20x1.25) MAGNET | 103 |
| 2 | 2 | - | A | 2-21006-6 | SCR, SKT SET (4-40x.62) DRAG | 102 |
| 1 | 1 | - | A | 21009-2 | SCR, SKT SET (1/4-20x.25) RAM | 101 |
| 2 | 2 | - | A | 21017-2 | SCR, DRIVE (#2x.19) ID PLATE | 100 |
| 1 | 1 | - | A | 1-21002-7 | SCR, BHC (6-32x.38) CAM | 99 |
| 1 | 1 | - | B | 461264-1 | PLATE, IDENTIFICATION | 98 |
| 1 | 1 | - | A | 6-23715-5 | SCR, PAN HD (6-32x1.50)FEED ADJ | 97 |
| 2 | 2 | - | A | 994991-5 | SCR, OVAL HD (M4X12) COUNTER | 96 |
| 2 | 2 | - | A | 2-21002-2 | SCR, BHC (8-32x.50) STRIPPER | 95 |
| 4 | 4 | - | A | 3-21002-0 | SCR, BHC (10-32x.87)HSG CAP | 94 |
| 1 | 1 | - | A | 22733-8 | SCR, BHC (8-32x.38 LW) ANVIL | 93 |
| 4 | 4 | - | A | 3-21002-3 | SCR, BHC (1/4-20x.50) ST GD PL | 92 |
| 3 | 3 | - | A | 2-22733-8 | SCR, BHC (1/4-20x.62) BASE PL | 91 |
| | | | | | | 90 |
| | | | | | | 89 |
| | | | | | | 88 |
| 2 | 2 | - | A | 2-21000-6 | SCR, SHC (8-32x.38) SLUG BLADE | 87 |
| 4 | 4 | - | A | 2-21000-7 | SCR, SHC (8-32x.50) STRIP GUIDE | 86 |
| | | | | | | 85 |
| 2 | 2 | - | A | 3-21000-7 | SCR, SKT CAP (10-32x.75)FD GDE | 84 |
| 2 | 2 | - | A | 1-21000-3 | SCR, SHC (4-40x.25) DRAG | 83 |
| 2 | 2 | - | A | 3-21000-6 | SCR, SKT CAP (10-32x.62)FD ADJ P | 82 |
| 1 | 1 | - | A | 3-21000-4 | SCR, SKT CAP (10-32x.38)PIVOT BL | 81 |
| 2 | 2 | - | A | 4-21000-0 | SCR, SKT CAP (10-32x1.25)SH PL | 80 |
| 1 | - | - | A | 1-455750-1 | GUARD ASSY | 79 |
| - | REF | - | A | 679532-1 | INSERT, GUARD | 78 |
| 1 | - | - | C | 465184-9 | LUBRICATOR ASSY | 77 |
| | | | | | | 76 |
| 1 | 1 | - | A | 238305-5 | SPACER, ADJ PLATE | 75 |
| 1 | 1 | - | A | 690603-1 | SPRING, ASSIST | 74 |
| 1 | 1 | - | A | 23030-1 | SCR, SKT CAP (6-32x.25) CP DSC | 73 |
| 1 | 1 | - | A | 458109-1 | WASHER, FLAT (SPECIAL) | 72 |
| 1 | 1 | - | A | 690517-1 | SPACER | 71 |

| QTY | RECD | PER | ASSY | PART NO | DESCRIPTION | ITEM NO |
|-----|------|-----|------|------------|------------------------------|---------|
| | | | | | | 60 |
| 1 | 1 | - | C | 458268-1 | CAP, RAM | 59 |
| 1 | 1 | - | D | 458267-1 | HOUSING | 58 |
| | | | | | | 57 |
| 1 | 1 | - | A3 | 1804299-1 | SPACER, MAGNET | 56 |
| 1 | 1 | - | B | 240624-1 | PIN, FEED FINGER | 55 |
| 1 | 1 | - | B | 691499-1 | SPRING, FEED FINGER | 54 |
| 1 | 1 | - | B | 694921-5 | FINGER, FEED | 53 |
| 1 | 1 | - | B | 240634-3 | LEVER, TERMINAL | 52 |
| 1 | 1 | - | A | 1804310-1 | MAGNET, RING | 51 |
| 1 | 1 | - | A | 1804303-1 | BRACKET, COUNTER MOUNTING | 50 |
| 1 | 1 | - | A | 1804300-1 | APPLICATOR COUNTER ASSEMBLY | 49 |
| 1 | - | - | B | 690501-3 | CAM, POST FEED 1 1/8 ST | 48 |
| - | 1 | - | B | 690501-4 | CAM, POST-FEED 1 5/8 ST | 47 |
| | | | | | | 46 |
| 1 | 1 | - | A | 690191-1 | PLUG, NYLON | 45 |
| 1 | 1 | - | C | 458266-2 | RAM | 44 |
| 1 | 1 | - | A | 690125-1 | WASHER, LAMINATED | 43 |
| 1 | 1 | - | A | 690124-1 | WASHER, RAM | 42 |
| 1 | 1 | - | A | 7-21002-9 | BOLT, CRIMPER (5/16-24x1.00) | 41 |
| 1 | 1 | - | A | 23241-6 | BALL, STEEL | 40 |
| 1 | 1 | - | A | 690170-1 | SPRING, COMPRESSION | 39 |
| 1 | 1 | - | C | 690142-1 | DISC, INSULATION | 38 |
| 1 | 1 | - | D | 354777-1 | WIRE DISC, PLASTIC | 37 |
| 1 | 1 | - | A | 22480-5 | WASHER, SPRING | 36 |
| 1 | 1 | - | B | 690212-1 | POST, RAM | 35 |
| | | | | | | 34 |
| | | | | | | 33 |
| | | | | | | 32 |
| | | | | | | 31 |
| 1 | 1 | - | B | 1-455888-0 | SPACER, CRIMPER | 30 |
| | | | | | | 29 |
| 1 | 1 | - | B | 2-690451-4 | SPACER, STRIPPER | 28 |
| 1 | 1 | - | A | 468281-1 | STRIPPER | 27 |
| 1 | 1 | - | C | 463915-1 | PLATE, BASE | 26 |
| 2 | 2 | - | A | 22354-8 | DRAG, STUD | 25 |
| 1 | 1 | - | B | 463903-1 | PLATE, STRIP GUIDE | 24 |
| | | | | | | 23 |
| 2 | 2 | - | A | 2-22281-3 | SPRING, DRAG | 22 |
| 1 | 1 | - | B | 464451-2 | ARM, STOCK DRAG | 21 |
| 1 | 1 | - | A | 1-464452-1 | DRAG, STOCK | 20 |
| 1 | 1 | - | B | 468699-2 | GUIDE, STRIP (REAR) | 19 |
| 1 | 1 | - | C | 468698-2 | GUIDE, STRIP (FRONT) | 18 |
| 1 | 1 | - | A | 1804305-2 | GUIDE, FEED ROD | 17 |
| 1 | 1 | - | A | 4-22284-9 | SPRING, FEED RETURN | 16 |
| | | | | | | 15 |
| 2 | 2 | - | B | 469633-3 | BLOCK, SUPPORT | 14 |
| | | | | | | 13 |
| | | | | | | 12 |
| 1 | 1 | - | B | 458255-1 | PLATE, REAR SHEAR | 11 |
| 2 | 2 | - | B | 1-240645-8 | SPACER, SHEAR PLATE | 10 |
| 1 | 1 | - | B | 455961-5 | PLATE, FRONT SHEAR | 9 |
| 1 | 1 | - | D | 8-356038-7 | ANVIL | 8 |
| 1 | 1 | - | B | 1-469634-2 | BLADE, SLUG | 7 |
| | | | | | | 6 |
| 1 | 1 | - | C | 3-238075-9 | SPACER, SLUG BLADE | 5 |
| 1 | 1 | - | B | 238009-1 | SPACER, BLOCK CRIMPER | 4 |
| 1 | 1 | - | C | 464113-6 | CRIMPER, INSULATION | 3 |
| 1 | 1 | - | B | 2-455888-4 | SPACER, CRIMPER | 2 |
| 1 | 1 | - | C | 1-464112-6 | CRIMPER, WIRE | 1 |

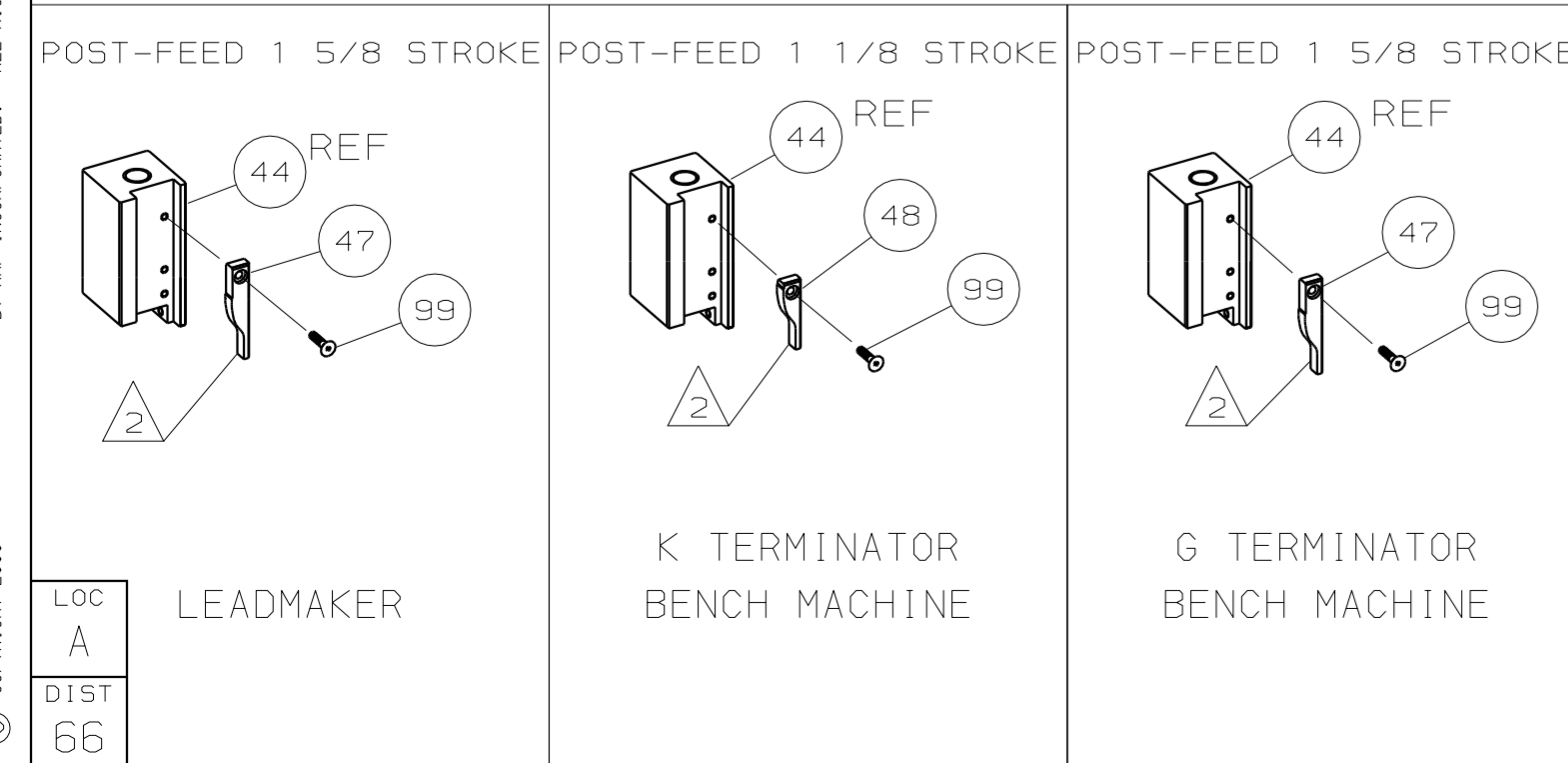

- 1 RECOMMENDED SPARE PARTS.
- 2 GREASE LIGHTLY.
- 3 GUARD MUST BE IN PLACE WHEN OPERATING APPLICATOR IN A BENCH MACHINE.
- 4 LUBRICATE DAILY USING NO. 20 MACHINE OIL.
- 5 STRIP GUIDE ADJUSTMENT REQUIRED TO CONVERT FROM LEFT TO RIGHT HAND TERMINALS OR VISE-VERSA.
- 6 ITEM 78 USED WITH G TERMINATOR ONLY.

| QTY | RECD | PER | ASSY | PART NO | DESCRIPTION | ITEM NO |
|-----|------|-----|----------|---------|-------------|---------|
| -2 | -1 | U/M | DWG SIZE | PART NO | DESCRIPTION | ITEM NO |

| QTY | RECD | PER | ASSY | PART NO | DESCRIPTION | ITEM NO |
|-----|------|-----|----------|---------|-------------|---------|
| -2 | -1 | U/M | DWG SIZE | PART NO | DESCRIPTION | ITEM NO |