

FMS6410

Dual Channel Video Drivers with Integrated Filters and Composite Video Summer

Video Features

- Dual integrated video low pass reconstruction filters on outputs
- Composite Video Summer
- Integrated output drivers provide low impedance outputs and deliver 2VP-P (6dB gain) video into 150Ω.
- 7.1MHz 4th order video filters
- 7.1MHz Y and C filters, with CV out
- 42dB stopband attenuation at 27MHz on Y, C, and CV
- Better than 1dB flatness to 4.5 MHz on Y, C, and CV
- No external frequency select components or clocks
- 9ns group delay flatness on Y, C, and CV output
- AC coupled inputs and outputs
- 0.4% differential gain with 0.4° differential phase
- Integrated DC Restore / Clamp circuitry with low tilt

Applications

- CCTV
- Cable and Satellite Set top boxes
- DVD players
- Televisions
- Personal Video Recorders (PVRs)
- Video On Demand (VOD)
- Distribution Amplifiers

General Description

The FMS6410 Dual Channel Video Filter – Driver Chip with CV Summer offers comprehensive video filtering for set top box or DVD applications. This part consists of two 4th order Butterworth 7.1MHz low pass filters for video signals. The filters are optimized for low overshoot and flat group delay. The device also contains a summing circuit to generate filtered composite video. Integrated video drivers are included to facilitate a direct drive to the outside world.

In a typical application, the Y and C input signals from DACs are AC coupled into the filter. Both channels have DC restore circuitry to clamp the DC input levels during video sync. The Y and C channels use a separate feedback clamp. The clamp pulse is derived from the Y channel.

The outputs are AC coupled. The Y, C and, CV outputs are buffered to drive 2VP-P into a 150Ω load (1VP-P into a doubly terminated 75Ω coax load) with up to 35pF of load capacitance at the output pin. The Y, C, and CV channels have a gain of approximately 2 (6dB) with 1VP-P input levels. There is an option for the video output to be DC coupled which limits the drive output to one output on each channel.

Functional Block Diagram

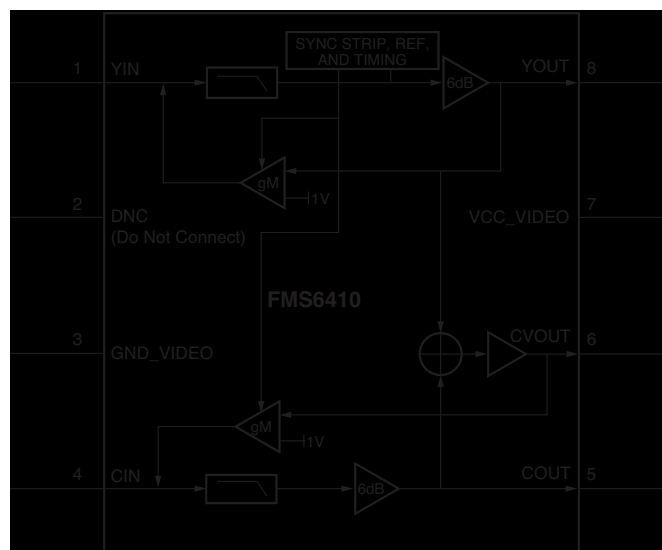

Pin Configuration

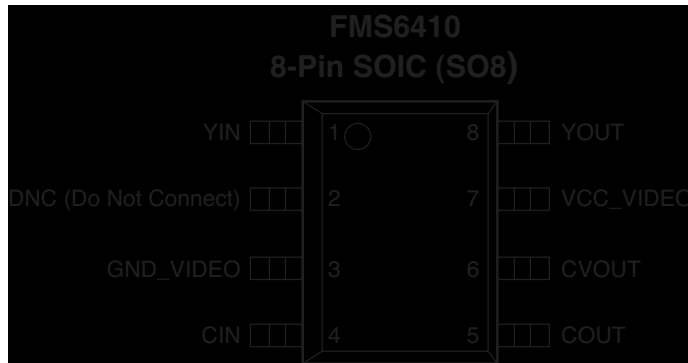

Video Section			
Pin#	Pin	Type	Description
1	YIN	Input	Luma (Luminance) / Composite Input
4	CIN	Input	Chroma (Chrominance) Input
5	COUT	Output	Filtered Chroma (Chrominance) Output
6	CVOUT	Output	Summed Composite Video Output
8	YOUT	Output	Filtered Luma (Luminance) Output
Power/Ground Pins			
7	VCC_VIDEO	Power	+5 VDC for Video
3	GND_VIDEO	Power	Ground for Video
2	DNC	DNC	Do Not Connect

Functional Description

Introduction

The FMS6410 is a dual monolithic continuous time video filter designed for reconstructing the luminance and chrominance signals from an S-Video D/A source. The Composite video output is generated by summing the filtered Y and C outputs. The chip is intended for use in applications with AC coupled inputs and AC coupled outputs (See Figure 1). The reconstruction filters approximate a 4th-order Butterworth characteristic with an optimization toward low overshoot and flat group delay. Y, C, and CV outputs are capable of driving 2V_{p-p} into AC coupled 150Ω video loads with up to 35pF of load capacitance at the output pin. All channels are clamped during sync to establish the appropriate output voltage swing range. Thus the input coupling capacitors do not behave according to the conventional RC time constant. Clamping for all channels settles to less than 10mv within 5ms of a change in video input sources. In most applications the input coupling capacitors are 0.1μF. The Y and C inputs typically sink 1μA during active video, which nominally tilts a horizontal line by about 2mV at the Y output. During sync, the clamp typically sources 20μA to restore the DC level. The net result is that the average input current is zero. Any change in the input coupling capacitor's value will inversely alter the amount of tilt per line. Such a change will also linearly affect the clamp response times. This product is robust and stable under all stated load and input conditions. Capacitive bypassing of VCC directly to ground ensures this performance.

Luminance (Y) I/O

The luma input is driven by either a low impedance source of 1V_{p-p} or the output of a 75Ω terminated line. The input is required to be AC coupled via a 0.1μF coupling capacitor which allows for a settling time of 5ms. The luma output is capable of driving an AC coupled 150Ω load at 2V_{p-p}, or 1V_{p-p} into a doubly terminated 75Ω load. Up to 35pF of load capacitance (at the output pin) can be driven without stability or slew issues. The output is AC coupled with a 220μF or larger AC coupling capacitor.

Chrominance (C) I/O

The chroma input is driven by a low impedance source of 0.7V_{p-p} or the output of a 75Ω terminated line. The input is required to be AC coupled via a 0.1μF coupling capacitor which allows for a clamp setting time of 5ms. The chroma output is capable of driving an AC coupled 150Ω load at 2V_{p-p}, or 1V_{p-p} into a doubly terminated 75Ω load. Up to 35pF of load capacitance can be driven without stability or slew issues. A 0.1μF AC coupling capacitor is recommended at the output. Since chrominance signals do not contain low frequency components, the smaller 0.1μF cap is recommended instead of the 220μF cap to reduce circuit cost.

Composite Video (CV) Output

The composite video output is capable of driving 2 loads to 2V_{p-p}. It is intended to drive a TV and a VCR. Either the TV input or the VCR input can be shorted to ground and the other output will still meet specifications. Up to 35pF of load capacitance (at the output pin) can be driven without stability or slew issues.

DC Coupled Output Applications

The 220μF capacitor coupled with the 150Ω termination forms a high pass filter that blocks the DC while passing the video frequencies and avoiding tilt. Lower values such as 10μF would create a problem. By AC coupling, the average DC level is zero. Thus, the output voltages of all channels will be centered around zero. Alternately, DC coupling the output of the FMS6410 is allowable. There are several tradeoffs: The average DC level on the outputs will be 2V; Each output will dissipate an additional 40mW nominally; The application will need to accommodate a 1V DC offset sync tip; And it is recommended to limit each output to one 150Ω load.

Typical Applications

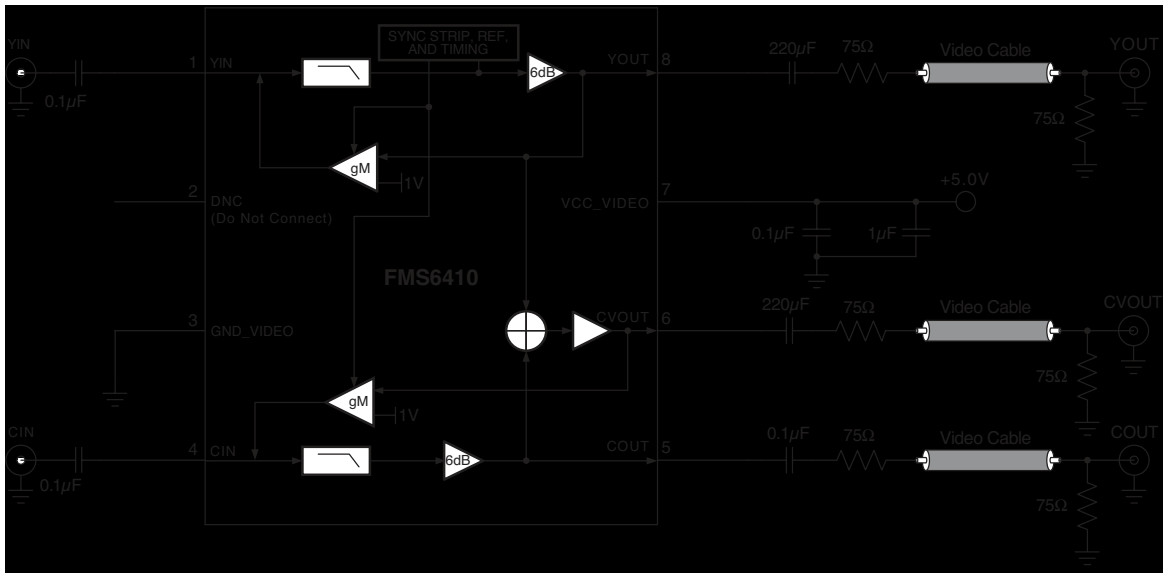

Figure 1. Typical Configuration

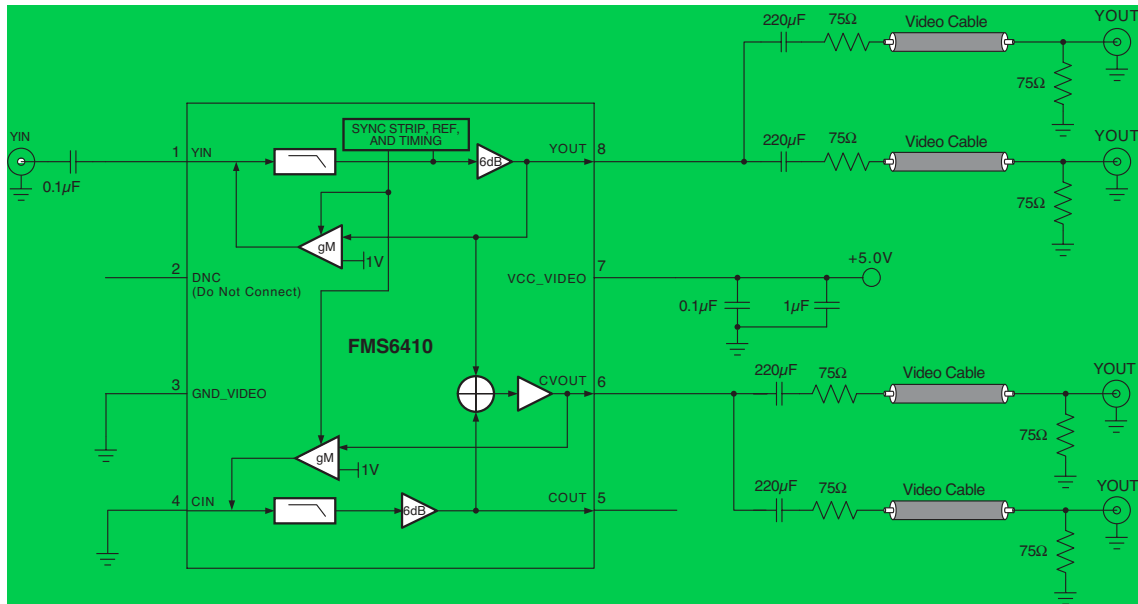

Figure 2. One Input to Four Output Distribution Amplifier Configuration

Typical Performance Graphs

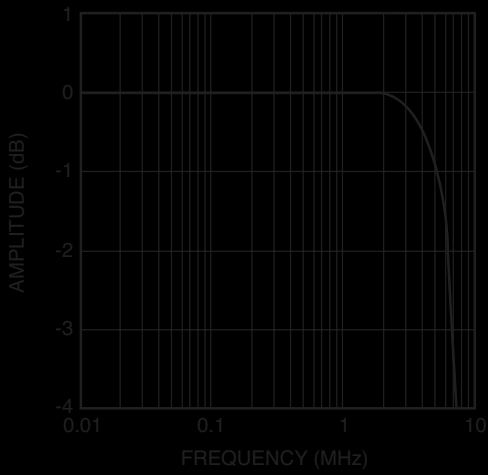

Figure 3. Passband Flatness for Y, C, and CV outputs (Normalized). Passband is ripple-free.

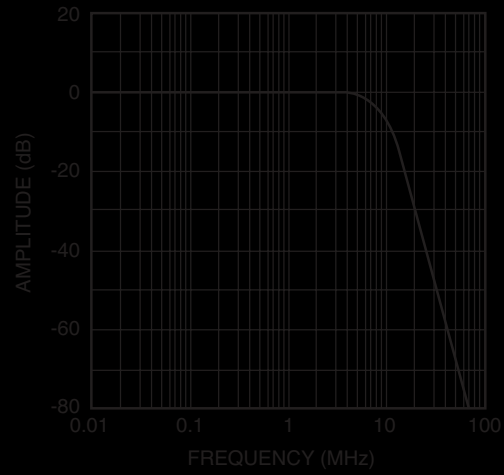

Figure 4. Passband/Stopband Rejection Ratios for Y, C, and CV outputs. (Normalized)

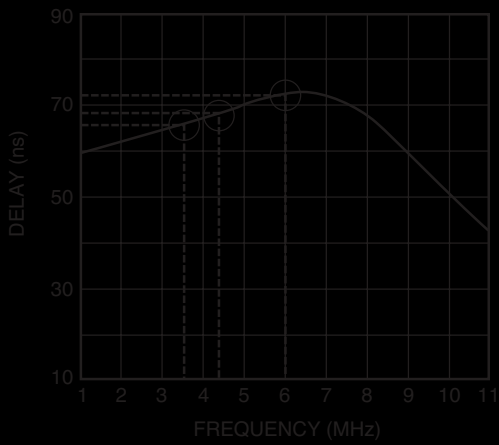

Figure 5. t_{PD} Propagation Delay for Y, C, and CV Outputs

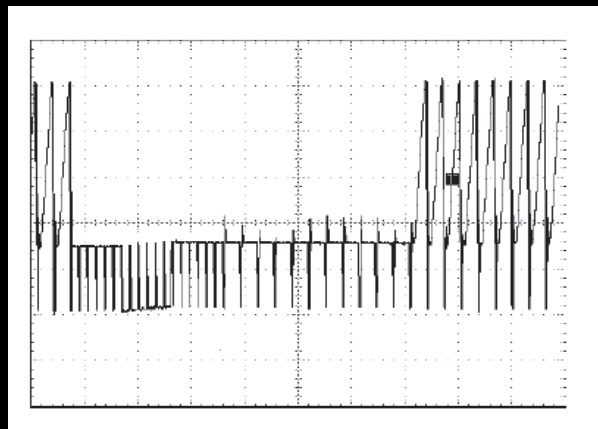

Figure 6. DC Restore Performance of Luma Output. Luma ramp test pattern is shown to have minimal tilt during vertical sync.

Absolute Maximum Ratings (beyond which the device may be damaged)

Parameter	Min	Max	Units
DC Supply Voltage	-0.3	+7.0	V
Analog I/O	GND-0.3	VCC+0.3	V
Output Current (Continuous)	CV Channel	60	mA
	Y and C Channels	30	mA
Junction Temperature		150	°C
Storage Temperature Range	-65	+150	°C
Lead Temperature (Soldering, 10s)		260	°C
Thermal Resistance (θ_{JA})		115	°C/W

Note: Functional operation under any of these conditions is NOT implied. Performance and reliability are guaranteed only if Operating Conditions are not exceeded.

Operating Conditions

Parameter	Min	Typ	Max	Units
Temperature Range	0		70	°C
VCC_VIDEO Range	4.75	5.0	5.25	V
ICC (+5 VDC), AC Coupled Outputs		60	85	mA

Electrical Characteristics 1Vp-p input signal at room temperature

Video Characteristics - Unless otherwise noted, typical output loading on video output is 150 Ω .						
Symbol	Parameter	Condition VCC_VIDEO=+5.0V+/-5%	Min	Typ	Max	Units
AVYC	Low Frequency Gain (YOUT, COUT)	at 400kHz	5.75	6.0	6.25	dB
AVCV	Low Frequency Gain (CVOUT)	at 400kHz	5.55	5.9	6.25	dB
YSYNC	YOUT Output Level (During Sync)	Sync Present on YIN	0.75	1.0	1.25	V
CSYNC	COUT Output Level (During Sync)	Sync Present on YIN	1.6	2.0	2.4	V
CVSYNC	CVOUT Output Level (During Sync)	Sync Present on YIN	0.75	1.0	1.25	V
tCLAMP	Clamp Response Time (Y Channel)	Settled to within 10mV, 0.1 μ F cap on YIN and CIN		5	9	ms
f _{1dB}	-1.0dB Bandwidth (Flatness) (YOUT, COUT, and CVOUT)	No Peaking Cap (Note 1)	4.0	4.5		MHz
f _C	-3dB Bandwidth (Flatness) (YOUT, COUT, and CVOUT)		6.7	7.1		MHz
f _{SB}	Stopband Rejection (YOUT, COUT, and CVOUT)	f _{IN} = 27MHz	-37	-42		dB
V _i	Input Signal Dynamic Range	AC Coupled (All Channels)	1.3	1.4		V _{P-P}
I _{SC}	Output Short Circuit Current (Note 2)	YOUT, COUT, CVOUT to GND		40	80	mA
C _L	Output Shunt Capacitance	All Channels		35		pF
d _G	Differential Gain (Note 3)	YOUT, COUT, and CVOUT		0.4	1	%
d _P	Differential Phase (Note 3)	YOUT, COUT, and CVOUT		0.4	1	°
THD	Output Distortion (All Channels)(Note 3)	YOUT / COUT = 1.8V _{P-P} at 3.58 / 4.43MHz		0.1	0.5	%

Electrical Characteristics 1Vp-p input signal at room temperature (continued)

Video Characteristics - Unless otherwise noted, typical output loading on video output is 150Ω.						
Symbol	Parameter	Condition VCC_VIDEO=+5.0V+/-5%	Min	Typ	Max	Units
XTALK	Crosstalk (Note 3)	From C _{IN} of 0.5V _{P-P} at 3.58MHz to Y _{OUT}	-45	-55		dB
		From Y _{IN} Input of 0.4V _{P-P} at 3.58MHz, to C _{OUT}	-50	-58		dB
PSRR	PSRR (All Channels) (Note 3)	0.5V _{P-P} (100kHz) at V _{CC}	-30	-40		dB
SNR	Y, C Channel (Note 3)	NTC-7 weighting 4.2 MHz lowpass	-65	-75		dB
	CV Channel (Note 3)	NTC-7 weighting 4.2 MHz lowpass	-60	-70		dB
t _{PD}	Propagation Delay (Y, C, CV) (Note 3)	100kHz	30	70	110	ns
Δt _{pd}	Group Delay Deviation from Flatness (Y, C, and CV) (Note 3)	to 3.58MHz (NTSC)		9		ns
		to 4.43MHz (PAL)		7		ns
t _{SKEW}	Skew between Y _{OUT} and C _{OUT} (Note 3)	at 1MHz		0		ns
T _{CLDCV}	Chroma-Luma Delay C _{VOUT}	f = 3.58MHz (referenced to Y _{IN} at 400kHz)	-35	0	35	ns
T _{CLGCV}	Chroma-Luma Gain C _{VOUT}	f = 3.58MHz (referenced to Y _{IN} at 400kHz)	92	95	104	%

Notes:

1. Peaking capacitor of 330pF increases output at 4.2MHz nominally by 0.7dB
2. Sustained short circuit protection limited to 10 seconds
3. Guaranteed by Characterization

Mechanical Dimensions Inches (millimeters)

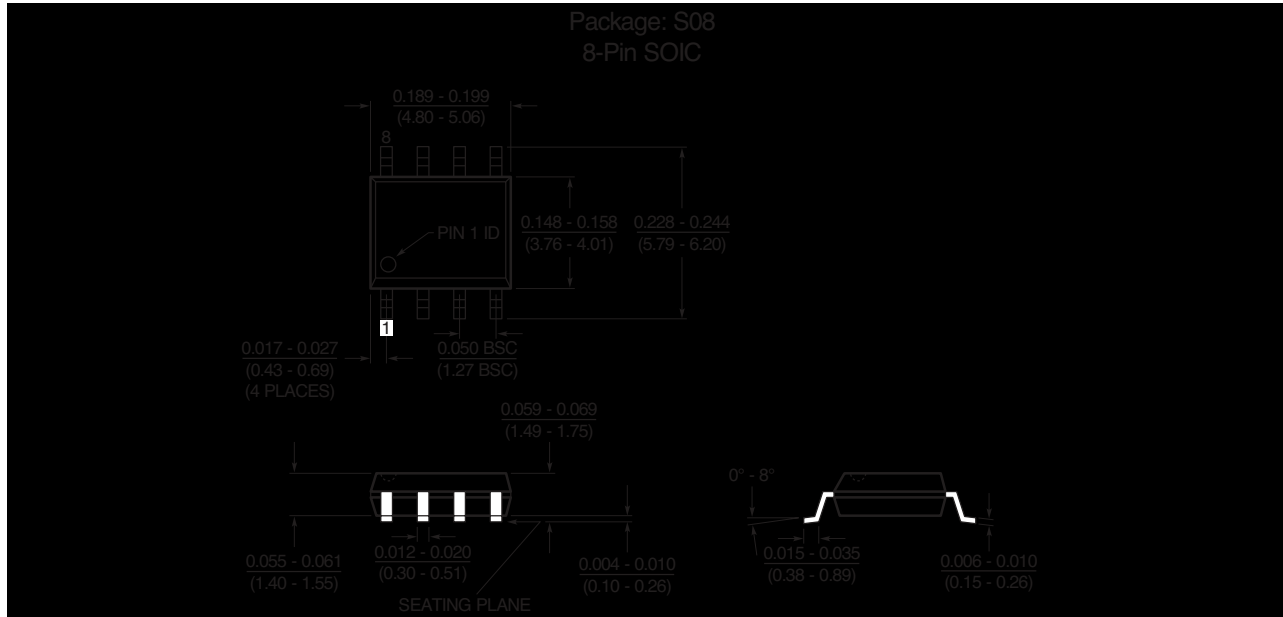

Ordering Information

Model	Part Number	Lead Free	Package	Container	Pack Quantity
FMS6410	FMS6410CS		SOIC-8	Tube	95
FMS6410	FMS6410CSX		SOIC-8	Tape and Reel	2500
FMS6410	FMS6410CS_NL		SOIC-8	Tube	95
FMS6410	FMS6410CSX_NL		SOIC-8	Tape and Reel	2500

DISCLAIMER

FAIRCHILD SEMICONDUCTOR RESERVES THE RIGHT TO MAKE CHANGES WITHOUT FURTHER NOTICE TO ANY PRODUCTS HEREIN TO IMPROVE RELIABILITY, FUNCTION OR DESIGN. FAIRCHILD DOES NOT ASSUME ANY LIABILITY ARISING OUT OF THE APPLICATION OR USE OF ANY PRODUCT OR CIRCUIT DESCRIBED HEREIN; NEITHER DOES IT CONVEY ANY LICENSE UNDER ITS PATENT RIGHTS, NOR THE RIGHTS OF OTHERS.

LIFE SUPPORT POLICY

FAIRCHILD'S PRODUCTS ARE NOT AUTHORIZED FOR USE AS CRITICAL COMPONENTS IN LIFE SUPPORT DEVICES OR SYSTEMS WITHOUT THE EXPRESS WRITTEN APPROVAL OF THE PRESIDENT OF FAIRCHILD SEMICONDUCTOR CORPORATION. As used herein:

1. Life support devices or systems are devices or systems which, (a) are intended for surgical implant into the body, or (b) support or sustain life, and (c) whose failure to perform when properly used in accordance with instructions for use provided in the labeling, can be reasonably expected to result in a significant injury of the user.
2. A critical component in any component of a life support device or system whose failure to perform can be reasonably expected to cause the failure of the life support device or system, or to affect its safety or effectiveness.