

CATALOG NUMBER	MATERIAL NUMBER	CABLE RANGE	LENGTH "M"	N.P.T. FITTING SIZE	FORM SIZE	UL LISTED	CSA APPROVED	PRODUCT SELECTION NUMBER
36491	-----	.187-.250 / 4.75-6.35	4.000±0.500 / 101.60±12.70	3/8	1	---		PG304F
36433	1300970228	.250-.312 / 6.35-7.92	4.250±0.500 / 107.95±12.70			---		PG305F
36434	-----	.312-.375 / 7.92-9.53	4.250±0.500 / 107.95±12.70			---		PG306F
36435	1300970229	.375-.437 / 9.53-11.10	5.500±0.500 / 139.70±12.70			---		PG307F
36280	1300970184	.187-.250 / 4.75-6.35	4.250±0.500 / 107.95±12.70	1/2	2	---		PG404F
36282	1300970185	.250-.375 / 6.35-9.53	4.250±0.500 / 107.95±12.70			---		PG406F
36284	1300970186	.375-.500 / 9.53-12.70	6.250±0.500 / 158.75±12.70			---		PG408F
36286	1300970187	.500-.625 / 12.70-15.88	6.500±0.500 / 165.10±12.70			---		PG410F
36290	1300970191	.250-.375 / 6.35-9.53	4.250±0.500 / 107.95±12.70	3/4	2	---		PG606F
36292	1300970627	.375-.500 / 9.53-12.70	6.250±0.500 / 158.75±12.70			---		PG608F
36294	1300970192	.500-.625 / 12.70-15.88	6.500±0.500 / 165.10±12.70			---		PG610F
36296	1300970496	.625-.750 / 15.88-19.05	6.000±0.500 / 154.40±12.70			---		PG612F
36818	1300970293	.375-.500 / 9.53-12.70	5.750±0.500 / 146.05±12.70	1	4	---		PG809F
36819	1300970628	.500-.625 / 12.70-15.88	5.750±0.500 / 146.05±12.70			---		PG811F
36298	1300970193	.625-.750 / 15.88-19.05	6.500±0.500 / 165.10±12.70			---		PG812F
36300	1300970194	.750-.875 / 19.05-22.23	8.500±1.000 / 209.55±25.40			---		PG814F
36302	1300970195	.875-1.000 / 22.23-25.40	9.250±1.000 / 234.95±25.40			---		PG816F

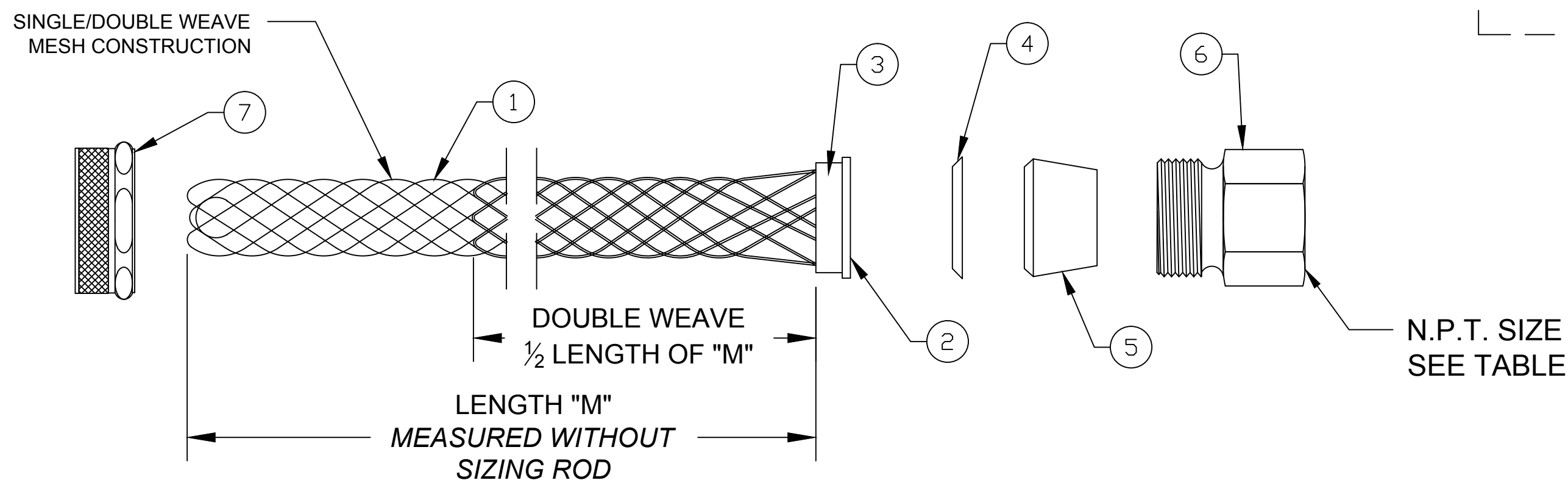
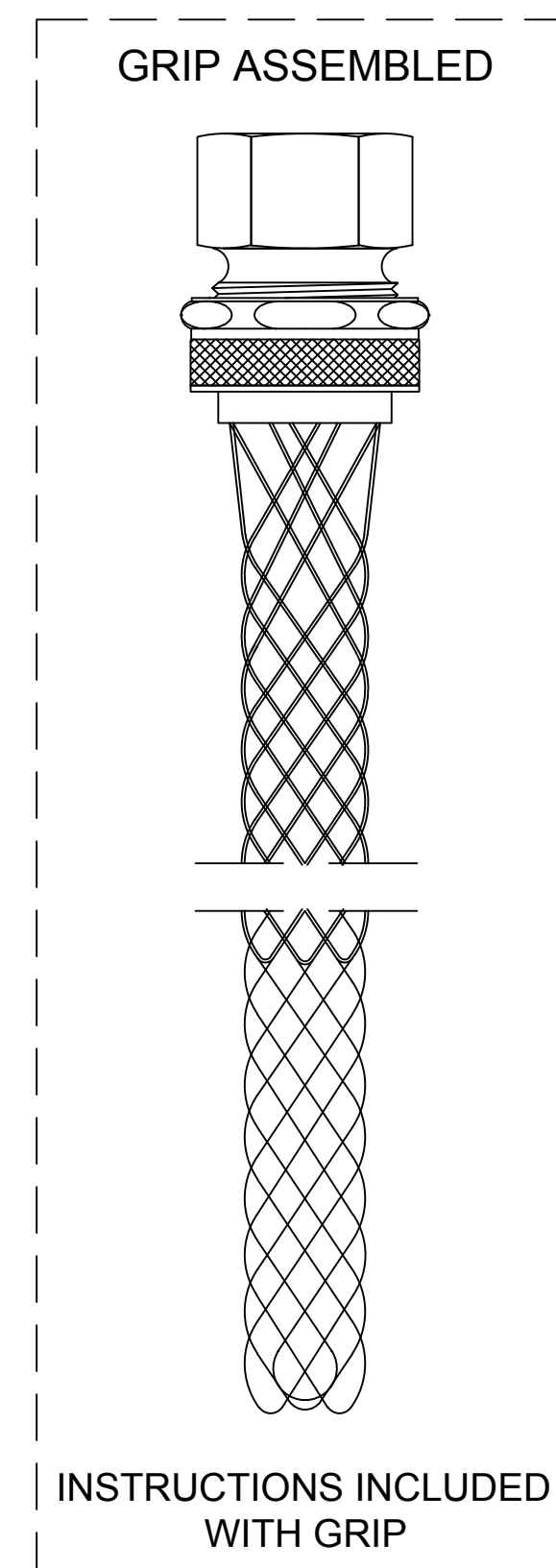

ITEM	DESCRIPTION	MATERIAL
1	WIRE MESH	STAINLESS STEEL
2	INNER RING	ALUMINUM
3	OUTER RING	ALUMINUM
4	FRICTION RING	ZINC PLATED STEEL
5	GROMMET	RUBBER
6	THREADED BODY	ALUMINUM
7	COMPRESSION NUT	ALUMINUM

36818 5.75" WAS 9.25"	EC NO: ICG2017-0557	12/1/16	DRWN: BPATTERS	CH'KD: ---	APPR: HKNEELAN 2016/05/04	DESCRIPTION	REV
QUALITY SYMBOL	▽=0	▽C=0					

	GENERAL TOLERANCES (UNLESS SPECIFIED)	
	mm	INCH
4 PLACES	±---	±---
3 PLACES	±---	±.005
2 PLACES	±.13	±.010
1 PLACE	±.25	±.020

ANGULAR ±1/2°

DRAFT WHERE APPLICABLE MUST REMAIN WITHIN DIMENSIONS

DIMENSION STYLE INCH/MM	
DRAWN BY	DATE
HRUIZ01	2014/10/14
CHECKED BY	DATE
HKNEELAN	2014/10/14
APPROVED BY	DATE
JFMURPHY	2016/05/04
MATERIAL NO.	SEE TABLE
SIZE	C

SCALE NTS	DESIGN UNITS INCH	THIRD ANGLE PROJECTION
TITLE		
STRAIN RELIEF DELUXE STRAIGHT FEMALE 3/8" TO 1" N.P.T.		
MOLEX INCORPORATED		SHEET NO. 1 OF 1
DOCUMENT NO. SD-130097-106		
THIS DRAWING CONTAINS INFORMATION THAT IS PROPRIETARY TO MOLEX INCORPORATED AND SHOULD NOT BE USED WITHOUT WRITTEN PERMISSION		