



ESSENTIAL INFORMATION

BUILD INSTRUCTIONS
CHECKING YOUR PCB & FAULT-FINDING
MECHANICAL DETAILS
HOW THE KIT WORKS

PLAY GAMES ON THE MOVE BY BUILDING THIS

ELECTRONIC DICE KIT

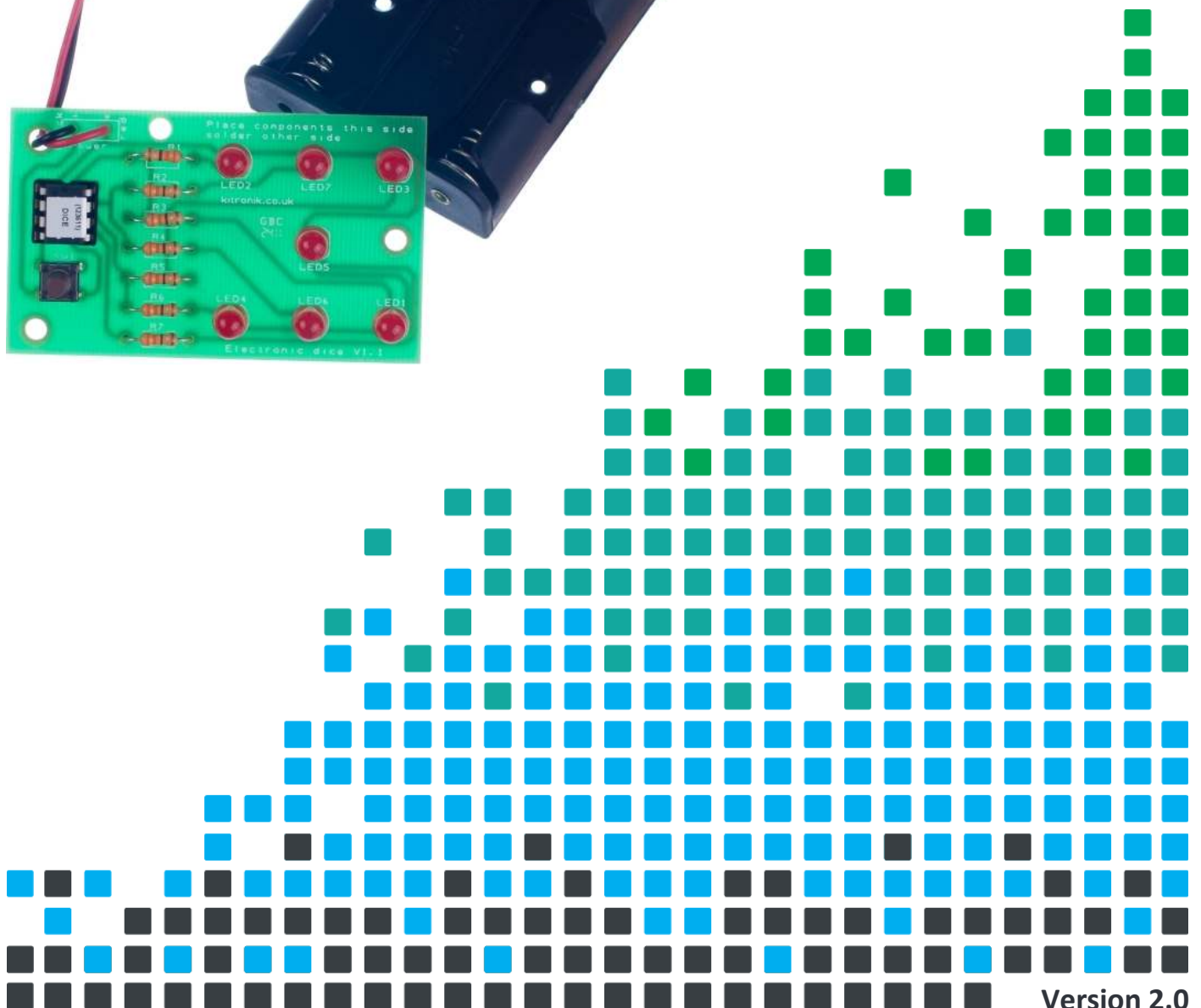
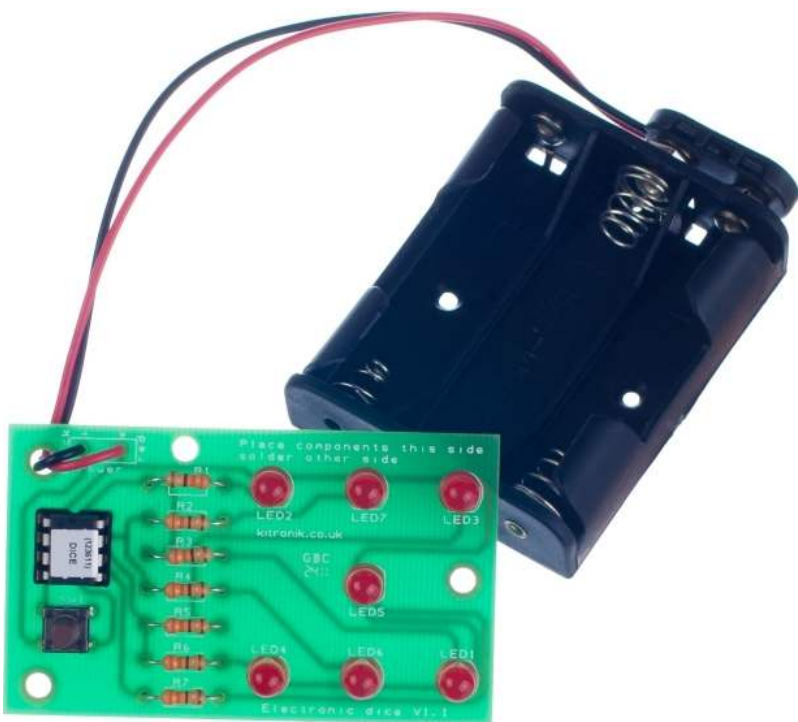

Build Instructions

Before you start, take a look at the Printed Circuit Board (PCB). The components go in the side with the writing on and the solder goes on the side with the tracks and silver pads.

1 PLACE RESISTORS

Start with the seven resistors, R1–R7, which are all 330Ω (orange, orange, brown coloured bands). The text on the PCB shows where R1, R2, etc go.



2 SOLDER THE IC HOLDER

Solder the Integrated Circuit (IC) holder into IC1. When putting this into the board, be sure to get it the right way around. The notch on the IC holder should line up with the notch on the lines marked on the PCB.



3 PLACE THE SWITCH

Insert the switch into the board where it is labelled SW1. Once you have got the pins lined up with the holes, they can be pushed firmly into place and soldered.



4 SOLDER THE LEDs

Solder the seven Light Emitting Diodes (LEDs) into LED1 – LED7. The LEDs won't work if they do not go in the right way around. If you look carefully one side of the LED has a flat edge, which must line up with the flat edge on the lines on the PCB.



5 FIT THE BATTERY CONNECTOR

The battery connector should be soldered into the 'Power' terminal. First feed the power clip through the strain relief hole next to the power connection. You should feed the wire from the solder side of the board. The red wire must go to the '+' terminal (also marked 'red') and the black wire must go to the '-' (also marked 'black') terminal.



6 INSERT INTEGRATED CIRCUIT (IC)

The IC can be put into the holder ensuring the notch on the chip lines up with the notch on the holder.

7 CONNECT THE BATTERIES

Connect the PP3 snap on to the 3xAA battery box. **Do not use a 9V battery with this circuit as it will destroy the IC.**



Checking Your Dice PCB

Check the following before you connect power to the board:

Check the bottom of the board to ensure that:

- All these leads are soldered.
- Pins next to each other are not soldered together.

Check the top of the board to ensure that:

- The notch on the IC holder / IC is next to the power connection.
- The flat edge of each of the LEDs match the outline on the board.
- The red and black power leads are connected to the correct pads (see the PCB markings).

Testing the PCB

Before testing the board it's worth checking to make sure that everything is in the correct place, as detailed above.

The software on the microcontroller has been specially designed to allow easy testing of the PCB. Each time the board is powered up, the LEDs will flash to the pattern shown right before it then works as a dice.

Power up your board and check that this sequence is displayed.

Push the switch and check that the lights flash and that a number is shown once the switch is released.

If your dice doesn't work as described, use the 'Checking Your Dice PCB' information above.

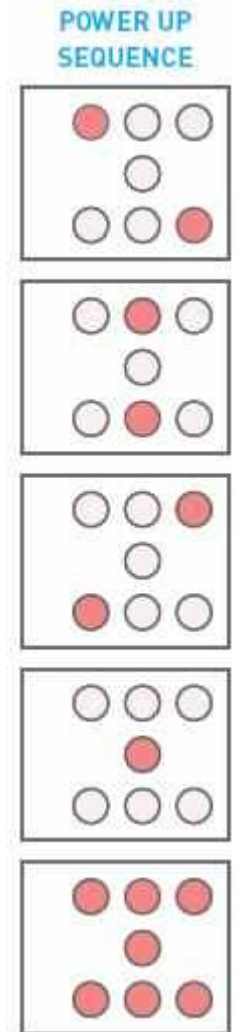

Fault finding flow chart - page 1

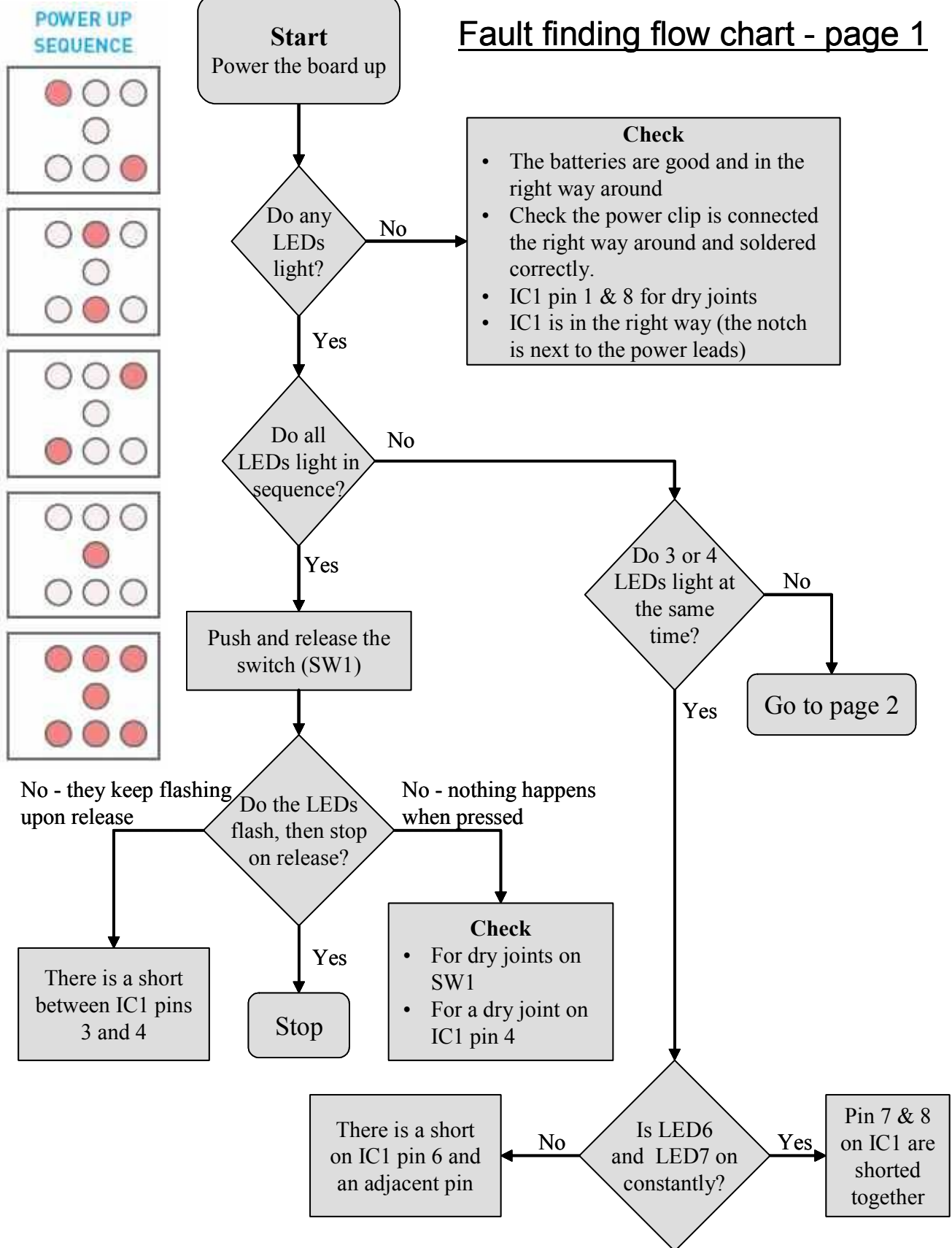

Fault finding flow chart - Page 2

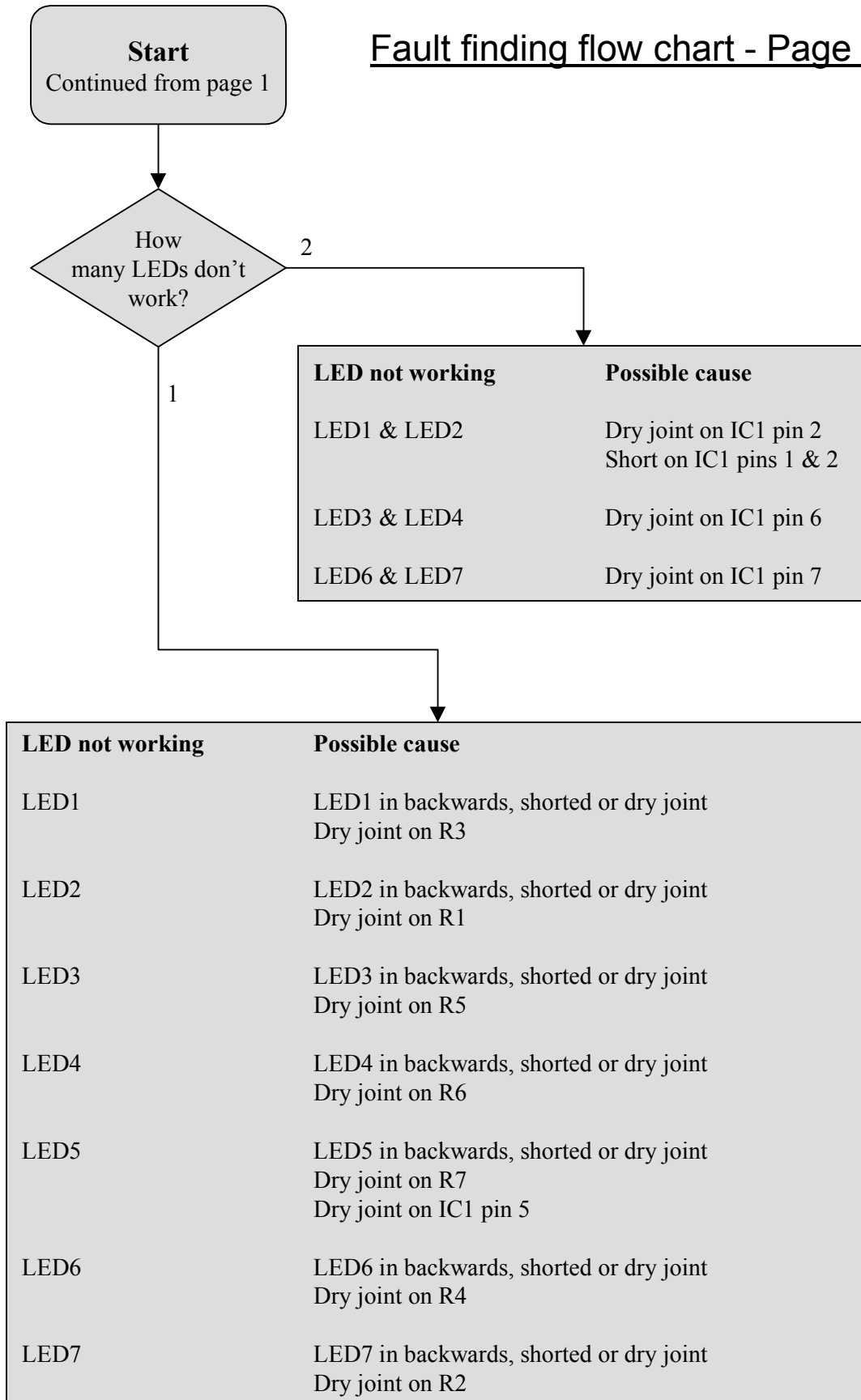

Designing the Enclosure

When you design the enclosure, you will need to consider:

- The size of the PCB (see below)
- Where the LEDs are mounted & how big they are (see below)
- Where the switch is located
- The size of the battery holder (shown right, height = 16mm)

These technical drawings of the dice PCB and the battery holder should help you to plan this.

All dimensions are in mm.

Diameter of the LEDs is 5mm and the height is 9mm.

Diameter of the three mounting holes is 3.3mm.

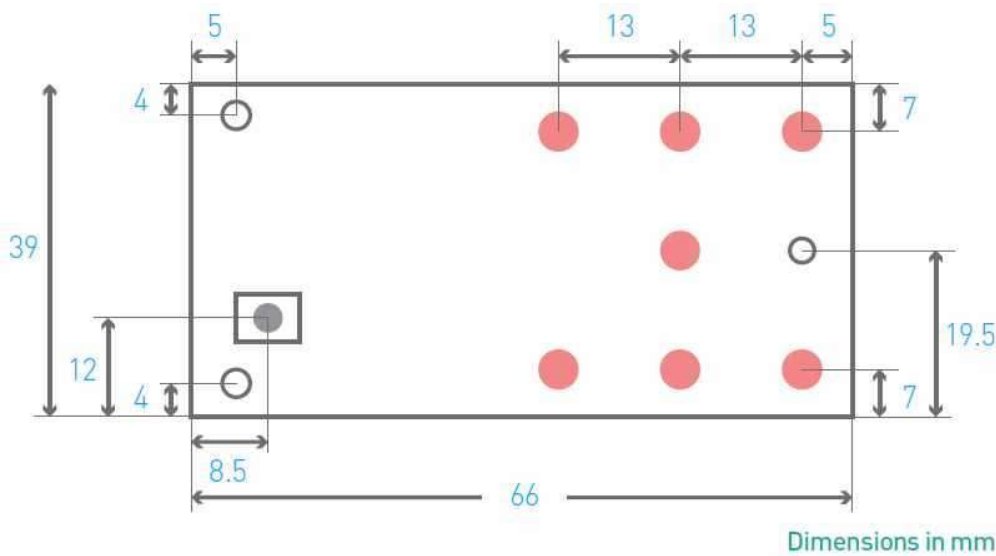
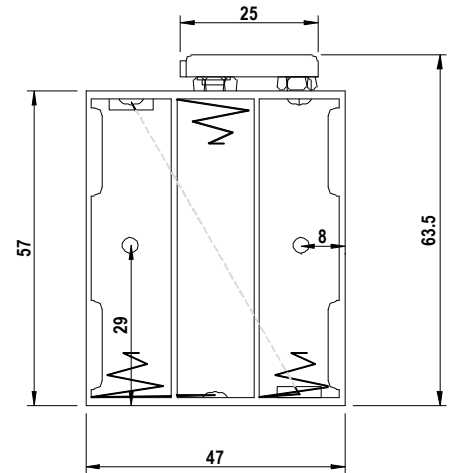

| | |
|---|--|
| <p>P.C.B</p> <p>SPACER</p> <p>ENCLOSURE</p> <p>2 X M3 BOLTS</p> | <p>Mounting the PCB to the enclosure</p> <p>The drawing to the left shows how a hex spacer can be used with two bolts to fix the PCB to the enclosure.</p> <p>Your PCB has four mounting holes designed to take M3 bolts.</p> |
|---|--|



How the Electronic Dice Works

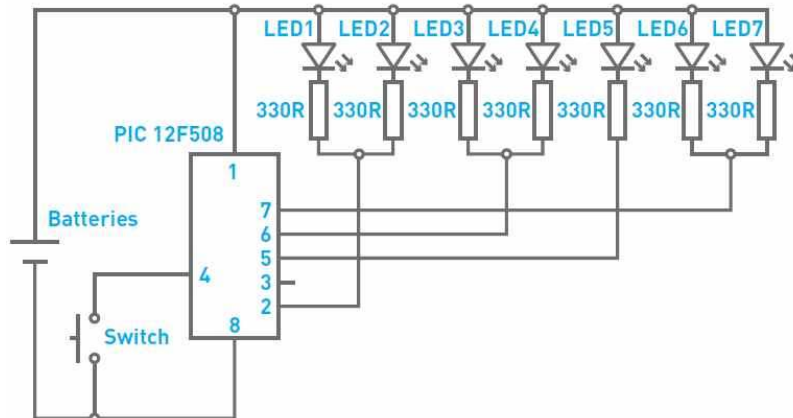

At the heart of the electronic circuit is a PIC microcontroller. A microcontroller is, in effect, a small computer. The circuit uses a push switch to detect when it should start generating the next number to be displayed. When the button is pressed the PIC very rapidly cycles through number 1 to 6, upon release of the button the number is displayed. The PIC then determines which of the LEDs should be lit up and sets pins 2, 5, 6 and 7 as required.

The relationship between the number that is to be displayed on the dice, the LEDs that need to be lit up, and the PIC pins that controls them, are shown in the table below.

| No. on dice | LEDs that are on | PIC Pins |
|-------------|------------------|----------|
| 1 | 5 | 5 |
| 2 | 1+2 | 2 |
| 3 | 1+2+5 | 2+5 |
| 4 | 1+2+3+4 | 2+6 |
| 5 | 1+2+3+4+5 | 2+5+6 |
| 6 | 1+2+3+4+6+7 | 2+6+7 |

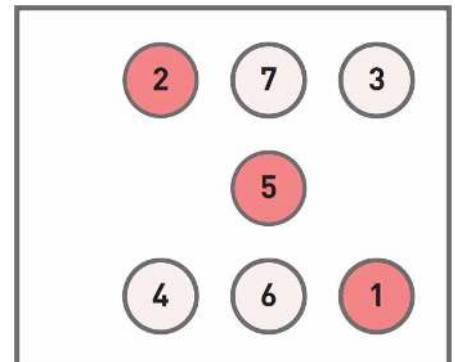

So, for example, if the number 3 (shown right) was to be displayed on the dice, this would require LEDs 1, 2 and 5 to be lit. These are controlled by PIC pins 2 and 5 (pin 2 controls LEDs 1 and 2). As the cathode of the LEDs are permanently connected to V+, the LEDs are turned on by taking their associated PIC pin low. This creates a voltage across the LED(s) and turns it/them on.

The value of resistors R1-R7 is 330Ω. These resistors limit the current that can flow through the LEDs. This protects the LEDs and controls their brightness.

Using your dice

- When the button is pressed a number is shown on the dice.
- Pressing the button again will display a new number.
- After a number has been displayed for 30 seconds the LEDs go out and the microcontroller goes to sleep. In this state it takes virtually no power so the batteries can be left connected when the dice is not in use. Next time the button is pressed the dice wakes up and functions as normal.



Online Information

Two sets of information can be downloaded from the product page where the kit can also be reordered from. The 'Essential Information' contains all of the information that you need to get started with the kit and the 'Teaching Resources' contains more information on soldering, components used in the kit, educational schemes of work and so on and also includes the essentials. Download from:

www.kitronik.co.uk/2109



This kit is designed and manufactured in the UK by Kitronik

Telephone: +44 (0) 845 8380781

Sales email: sales@kitronik.co.uk

Tech support email: support@kitronik.co.uk

Web: www.kitronik.co.uk



www.kitronik.co.uk/twitter



www.kitronik.co.uk/facebook



www.kitronik.co.uk/youtube



www.kitronik.co.uk/google

Every effort has been made to ensure that these notes are correct, however Kitronik accept no responsibility for issues arising from errors / omissions in the notes.

© Kitronik Ltd - Any unauthorised copying / duplication of this booklet or part thereof for purposes except for use with Kitronik project kits is not allowed without Kitronik's prior consent.

