

SECTION A-A

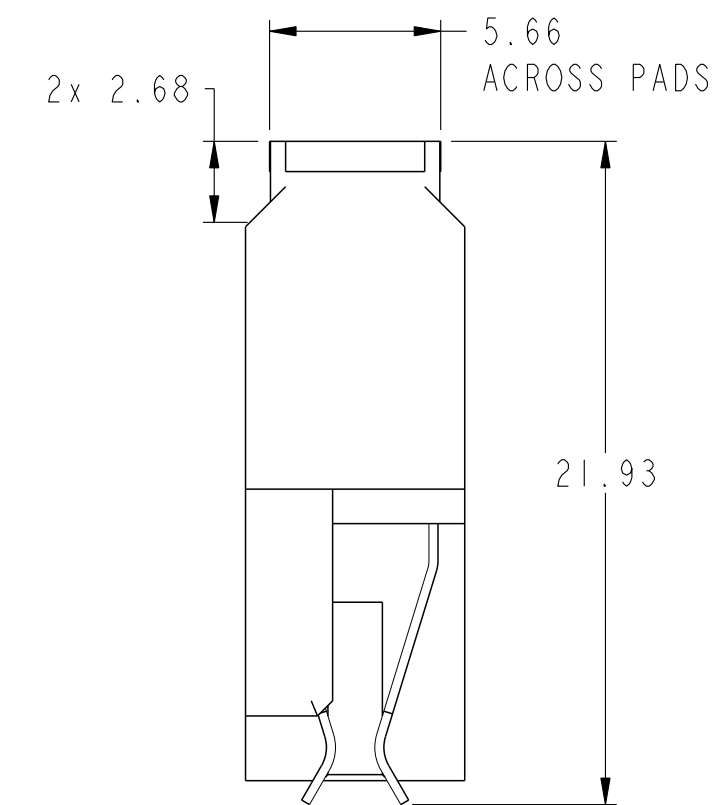

Copyright FCI.

spec ref	-	dr	Jackie Huang	2014-03-21	projection	MM	size	A2	scale	4:1
tolerance std	ISO 406 ISO 1101	eng	Jackie Huang	2014-03-21			ecn no	-	rel level	Released
TOLERANCES UNLESS OTHERWISE SPECIFIED		chr	FANCY ZHANG	2014-03-21						
surface	ISO 1302	appr	PM ZHENG	2014-03-21	product family	HPCE	dwg no	10129515	rev	A
	linear	0.X	±0.5		www.fci.com		cat. no.	-	Product - Customer Drw	sheet 1 of 4
		0.XX	±0.25		SMT ENHANCED WALLS					
		0.XXX	±0.10		40S (12S OMITTED) SPECIAL					
	angular	0°	±2°		PDS: Rev :A					
					STATUS:Released					
					Printed: May 15, 2014					

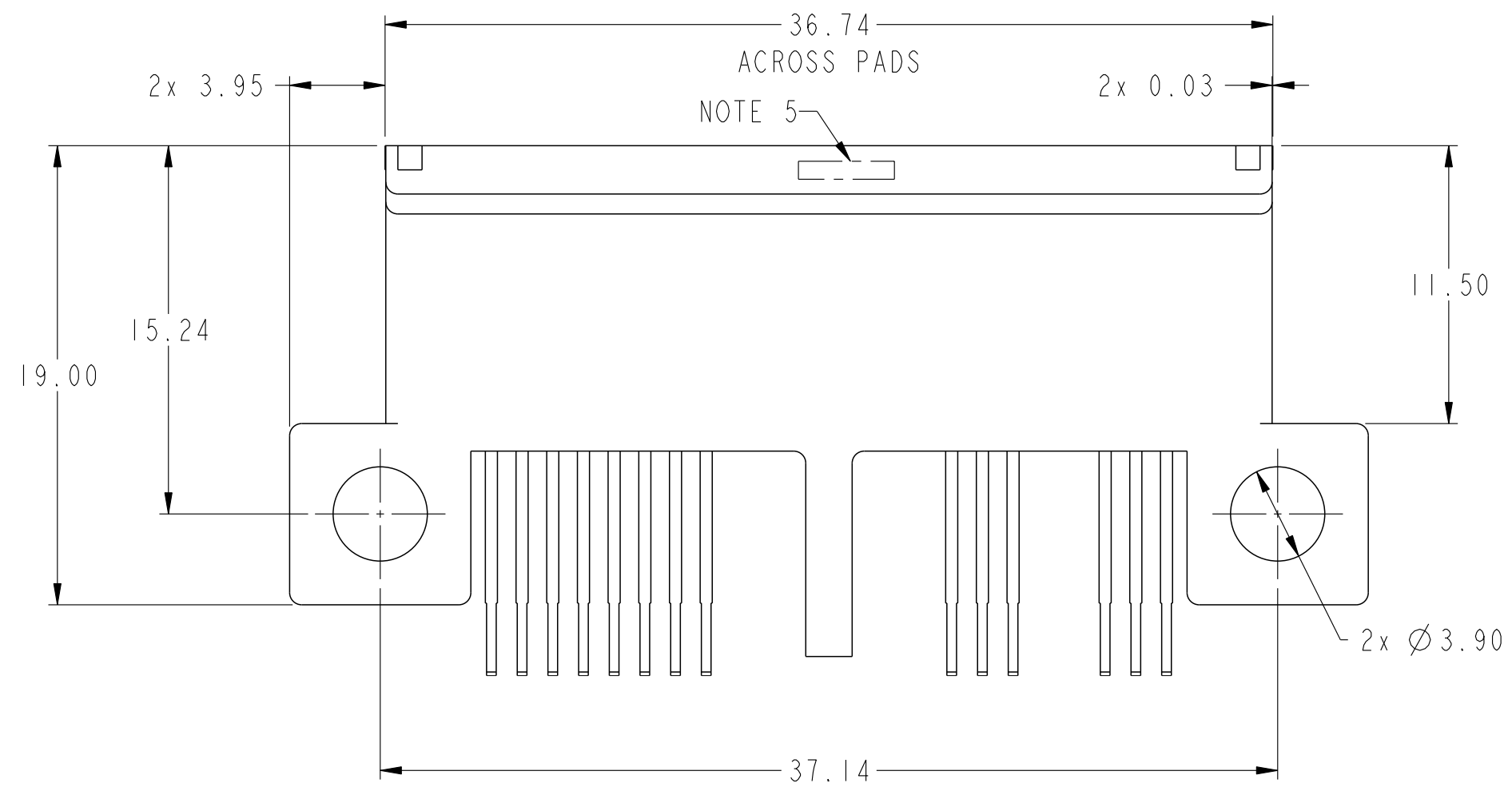
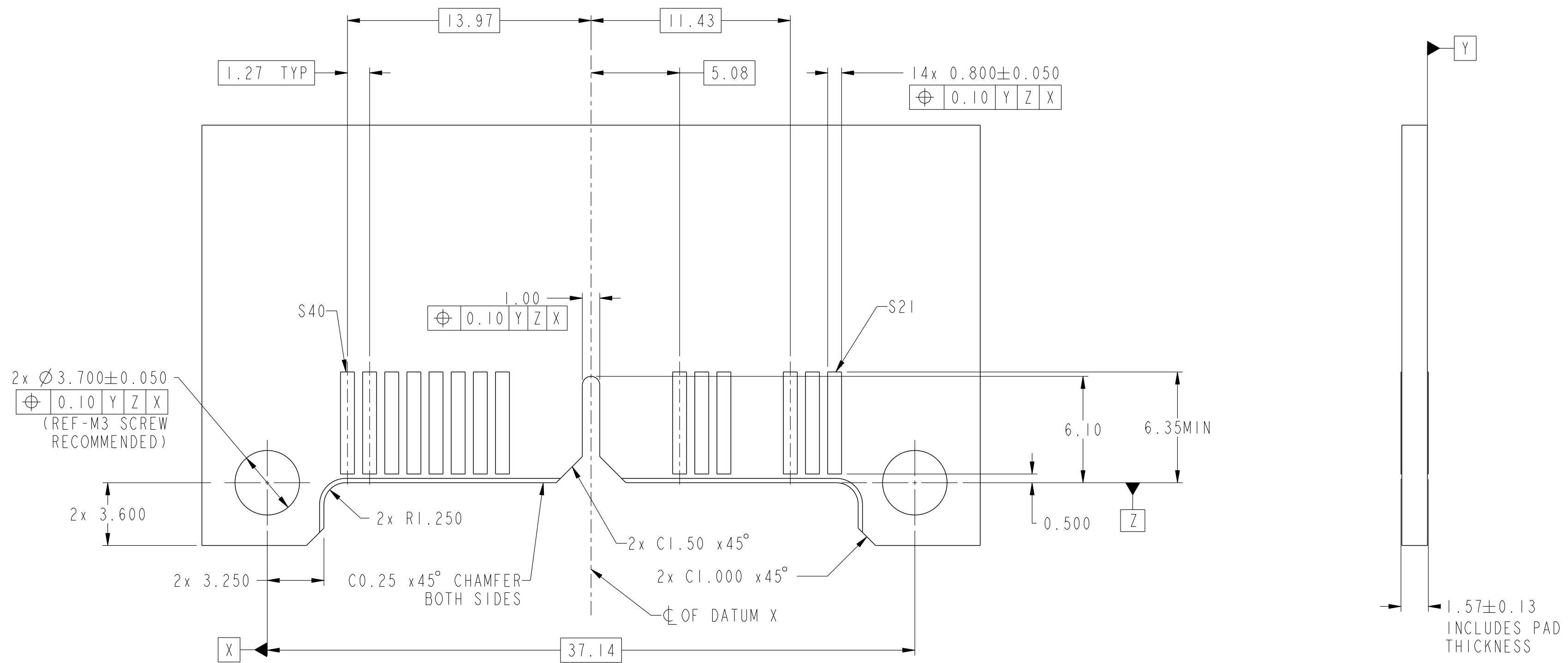

RECOMMENDED HOST BOARD LAYOUT AS VIEWED

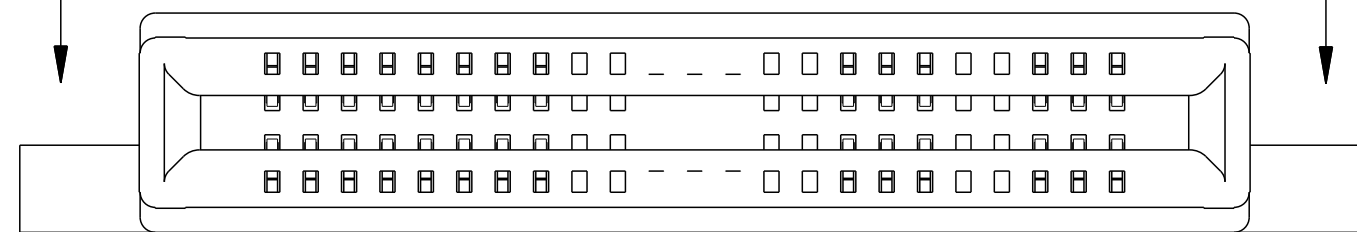

dr	Jackie Huang	2014-03-21	projection	MM	size	A2	scale	4:1
eng	Jackie Huang	2014-03-21			ecn no	-	rel level	Released
chr	FANCY ZHANG	2014-03-21						
appr	PM ZHENG	2014-03-21	product family	HPCE	rel level	Released		
			SMT ENHANCED WALLS 40S (12S OMITTED) SPECIAL			dwg no 10129515	rev A	
www.fci.com			cat. no.	-	Product - Customer Drw	sheet 2 of 4		

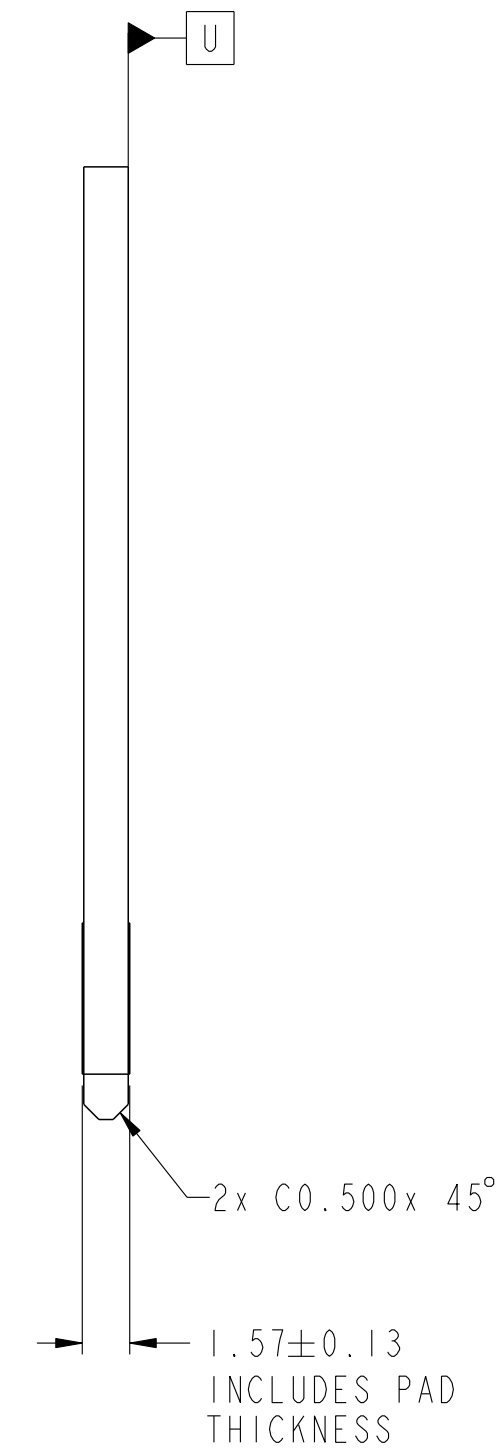
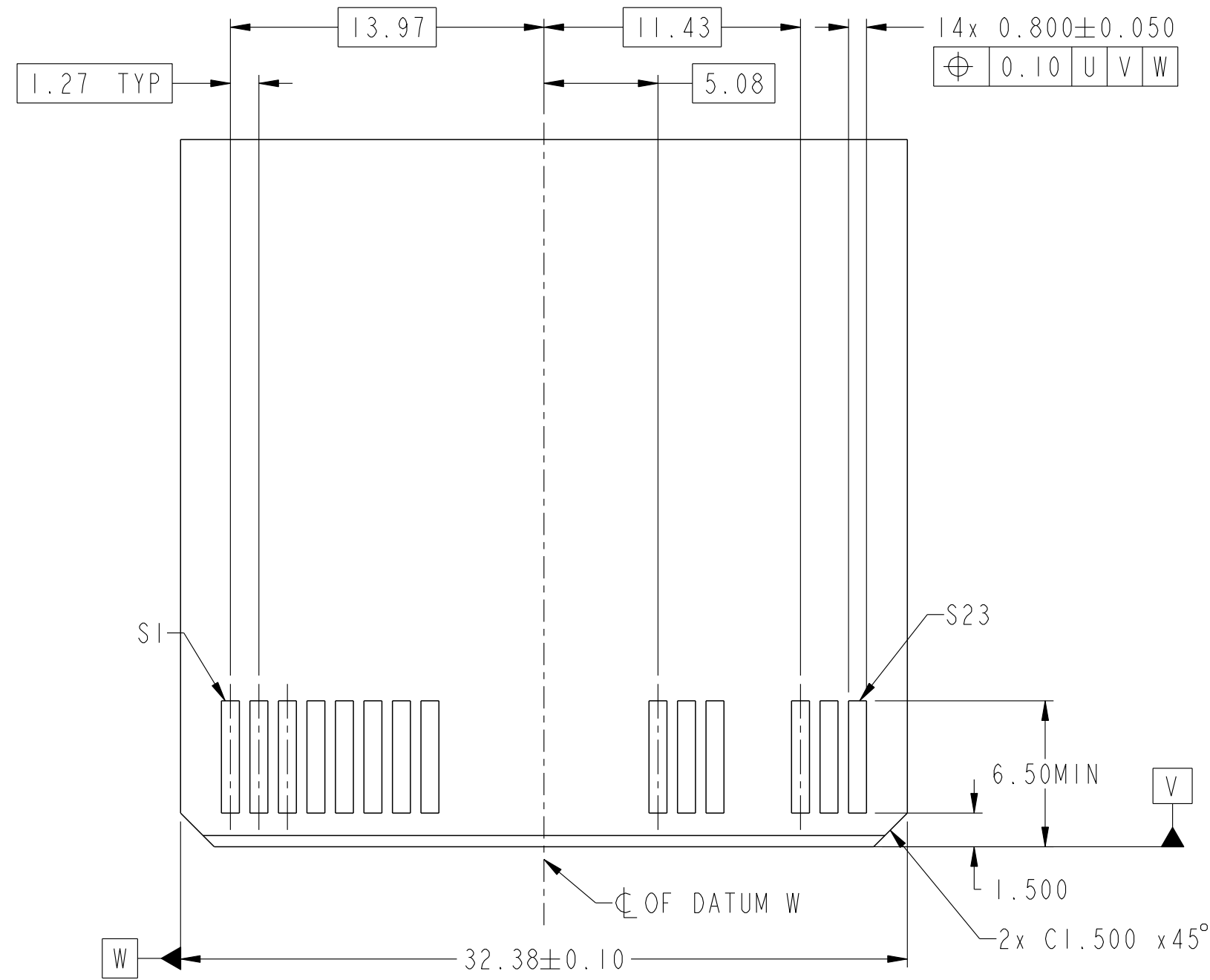

RECOMMENDED MATING BOARD
FOOTPRINT



Copyright FCI.

dr	Jackie Huang	2014-03-21	projection	MM	size	A2	scale	4:1
eng	Jackie Huang	2014-03-21			ecn no	-	rel level	Released
chr	FANCY ZHANG	2014-03-21						
appr	PM ZHENG	2014-03-21	product family	HPCE				
			title SMT ENHANCED WALLS 40S (12S OMITTED) SPECIAL		dwg no 10129515		rev A	
www.fci.com			cat. no.		-		Product - Customer Drw	

PART NUMBER	MOUNTING EARS
10129515-001LF	YES
10129515-002LF	NO

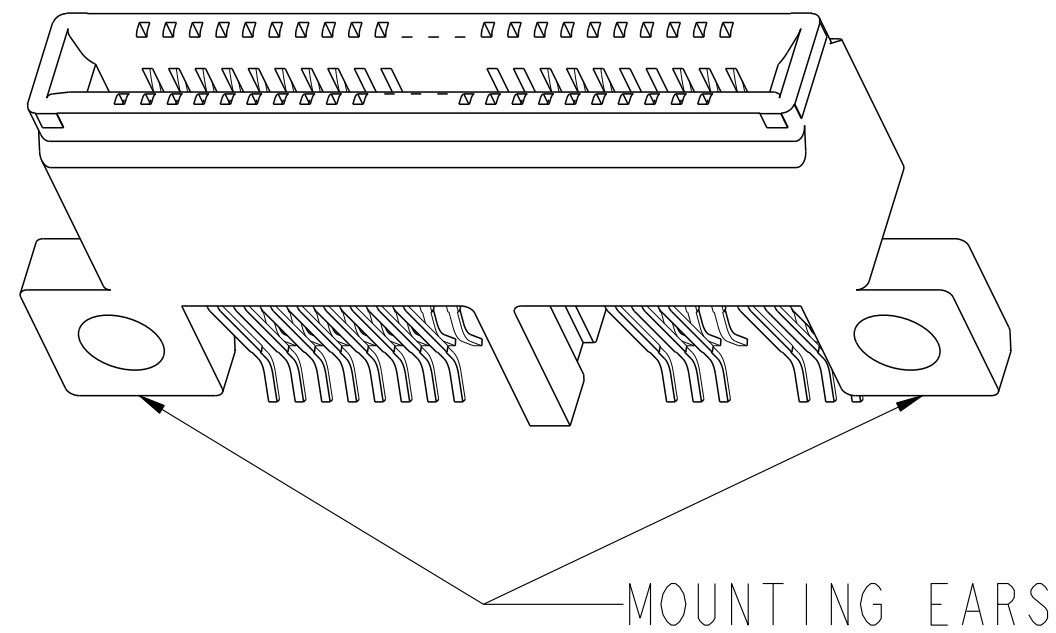

Example: 10129515-001LF

NOTES:

- CONNECTOR MATERIALS:
 HOUSING: HIGH TEMPERATURE THERMAL PLASTIC, BLACK
 UL 94V-0 COMPLIANT
 CONTACTS: HIGH PERFORMANCE COPPER ALLOY.
- CONTACT FINISH REF. GS-12-604 SECTION 5.2.
- PRODUCT SPECIFICATION: GS-12-604.
- APPLICATION SPECIFICATION: GS-20-128.
- PRODUCT MARKING (FCI - PART NUMBER & DATE CODE) ON HOUSING IN AREA SHOWN.
- PACKAGING MEETS FCI SPECIFICATION GS-14-937.
- HOUSING COMPONENT WILL WITHSTAND EXPOSURE TO 260°C PEAK TEMPERATURE FOR 60 SECONDS IN A CONVECTION, INFRA-RED, OR VAPOR PHASE REFLOW OVEN.

dr	Jackie Huang	2014-03-21	projection	MM	size	A2	scale	4:1	
eng	Jackie Huang	2014-03-21			ecn no	-	rel level	Released	
chr	FANCY ZHANG	2014-03-21							
appr	PM ZHENG	2014-03-21	product family	HPCE					
			title	SMT ENHANCED WALLS		dwg no	10129515		
www.fci.com			cat. no.	-		Product - Customer Drw	sheet 4 of 4	rev	A