

P	LTR	DESCRIPTION	DATE	DWN	APVD
A		REVISED PER ECR-18-017862	22NOV2018	SR	DD
B		REVISED PER ECR-19-008311	06JUN2019	SR	DD
B1		REVISED PER ECR-19-015297	01OCT2019	SB	DD
B2		REVISED PER ECR-20-009266	09JUL2020	SB	DD

- 1. MATERIAL:  
- POLYCARBONATE COLOR: SEE TABLE
- 2. MUST COMPLY WITH DIRECTIVE 2002/95/EC (ROHS)
- 3. THIS PRODUCT HAS NOT COMPLETED VALIDATION TESTING
- 4. MODULE BASE TE P/N: 2213837-1
- 5. PACKAGED 66 PER PLASTIC TRAY  
DIM X = 24.25 - 7 TRAYS PER BOX  
DIM X = 39.25 - 4 TRAYS PER BOX

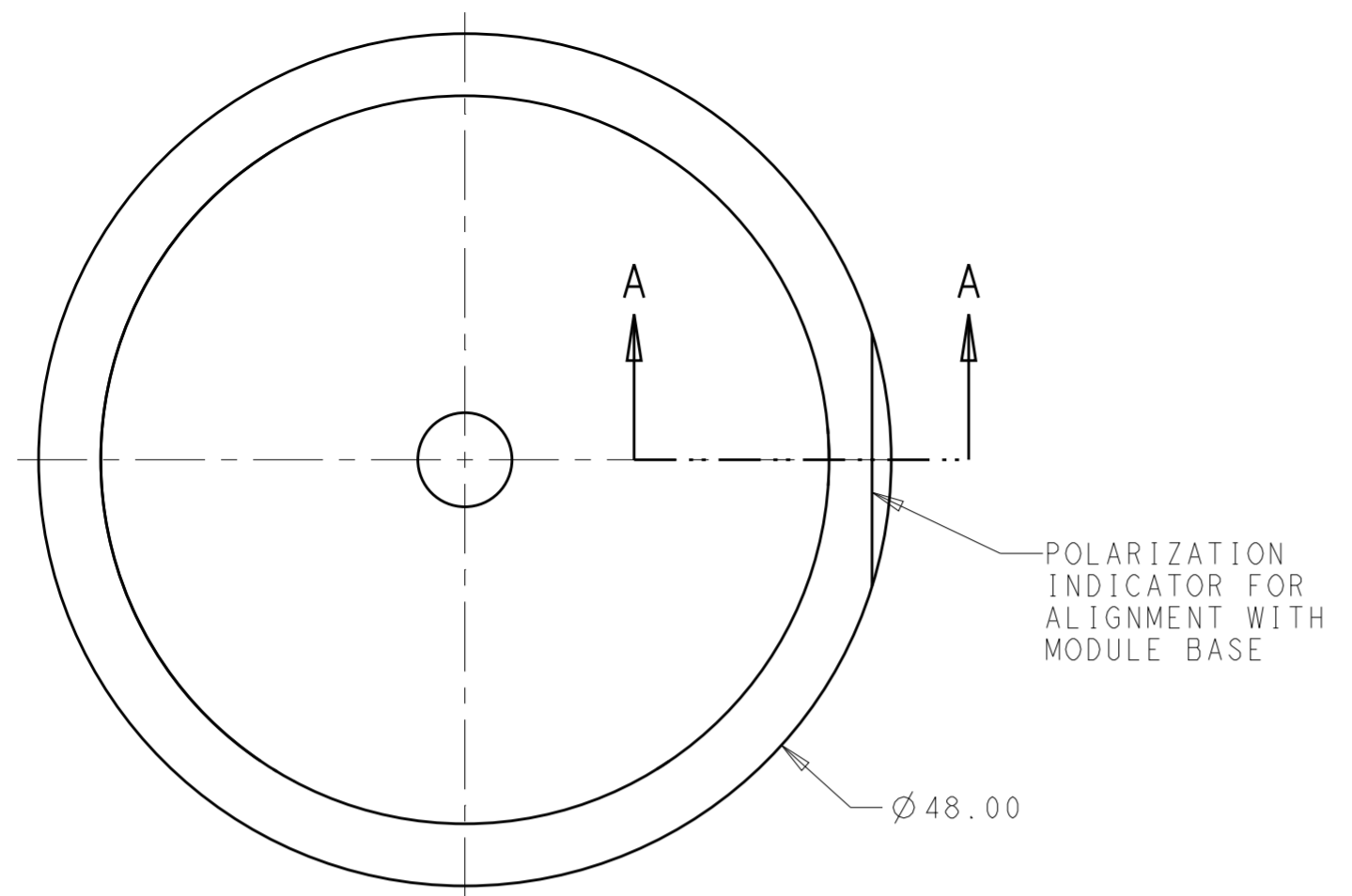

POLARIZATION INDICATOR FOR ALIGNMENT WITH MODULE BASE

Ø48.00

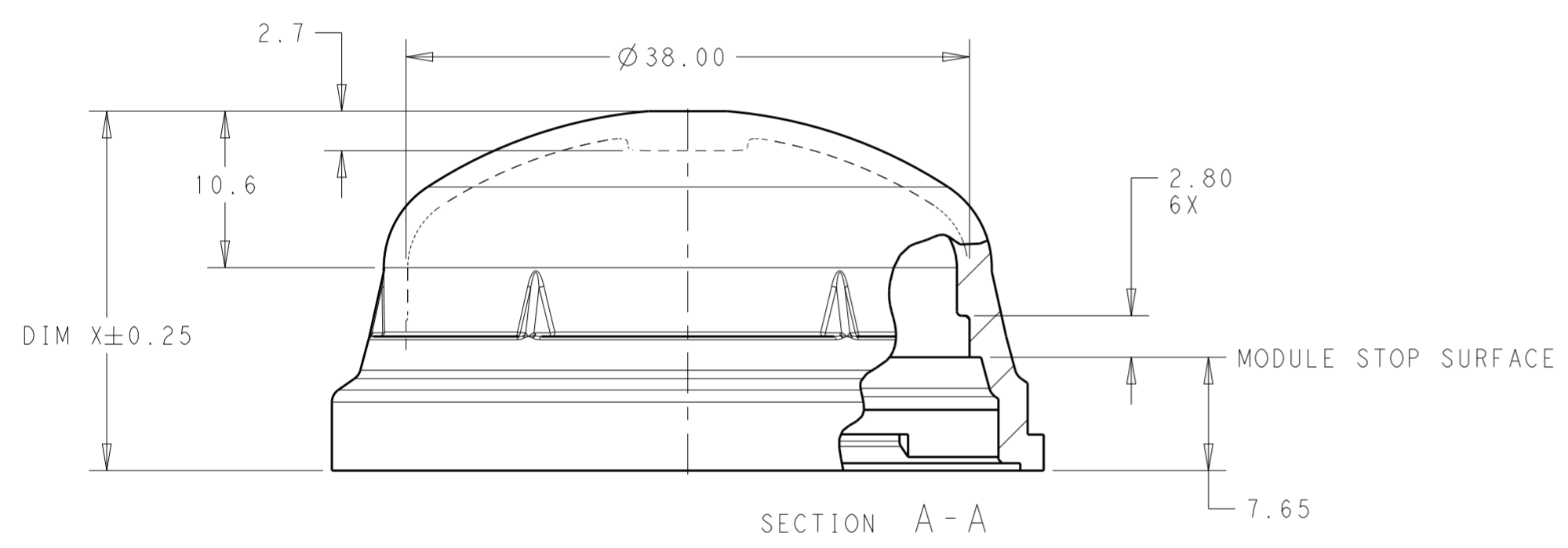

SECTION A-A

MODULE STOP SURFACE

POLARIZATION FEATURES

LATCH 3X

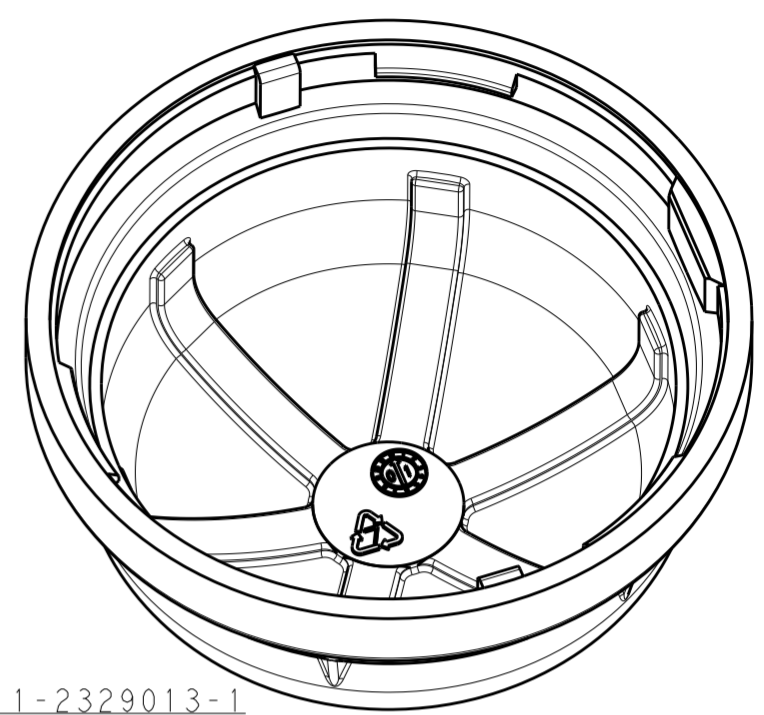
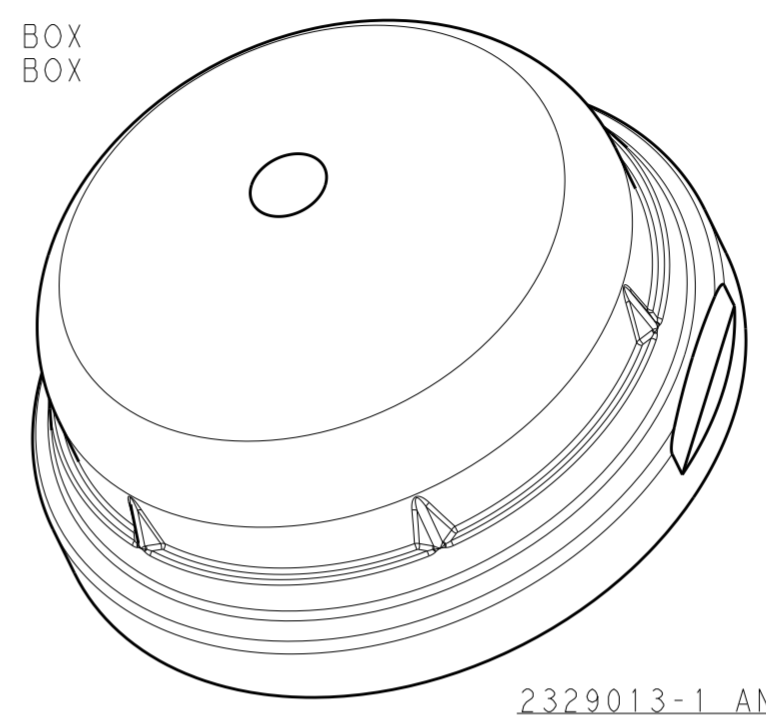
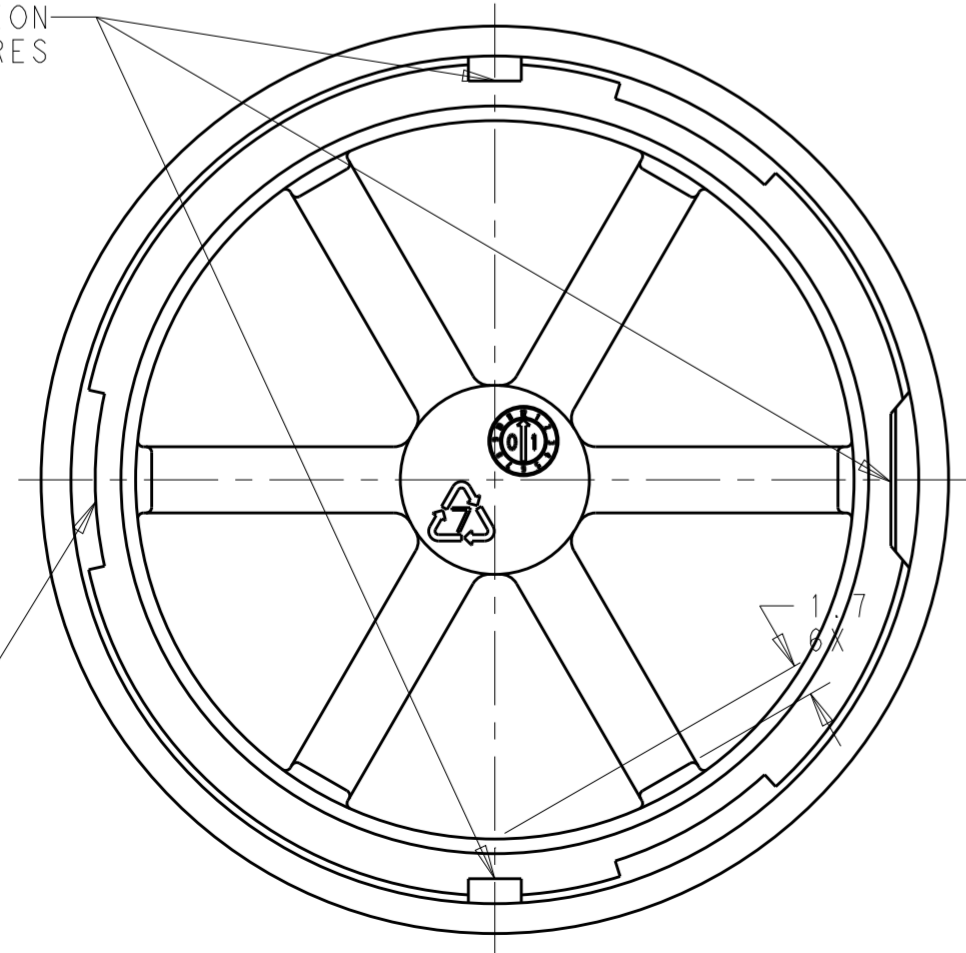

2329013-1 AND 1-2329013-1  
SHOWN  
SCALE 2:1

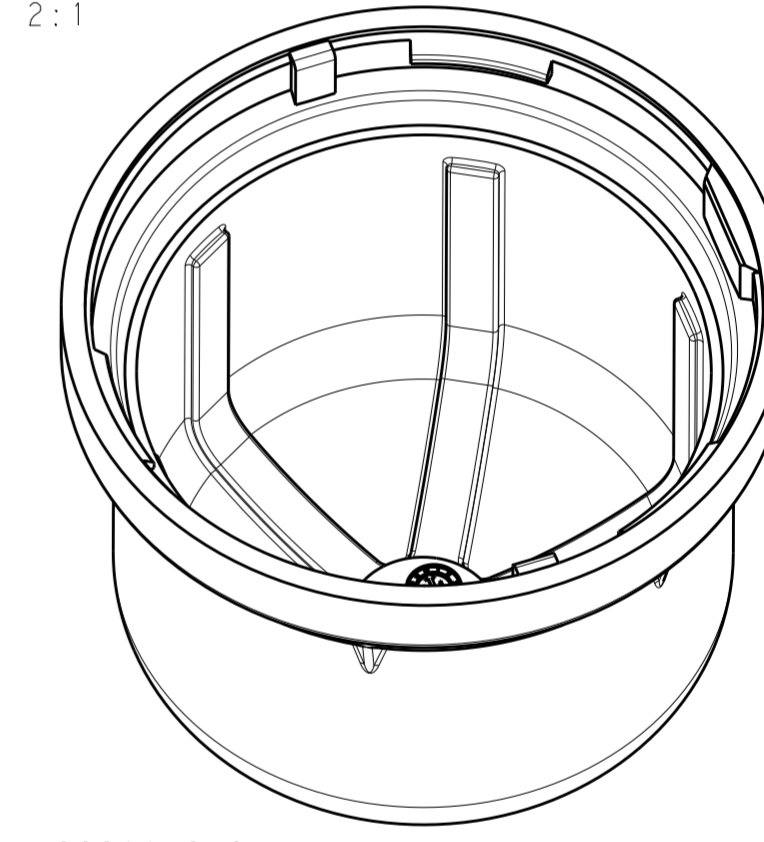
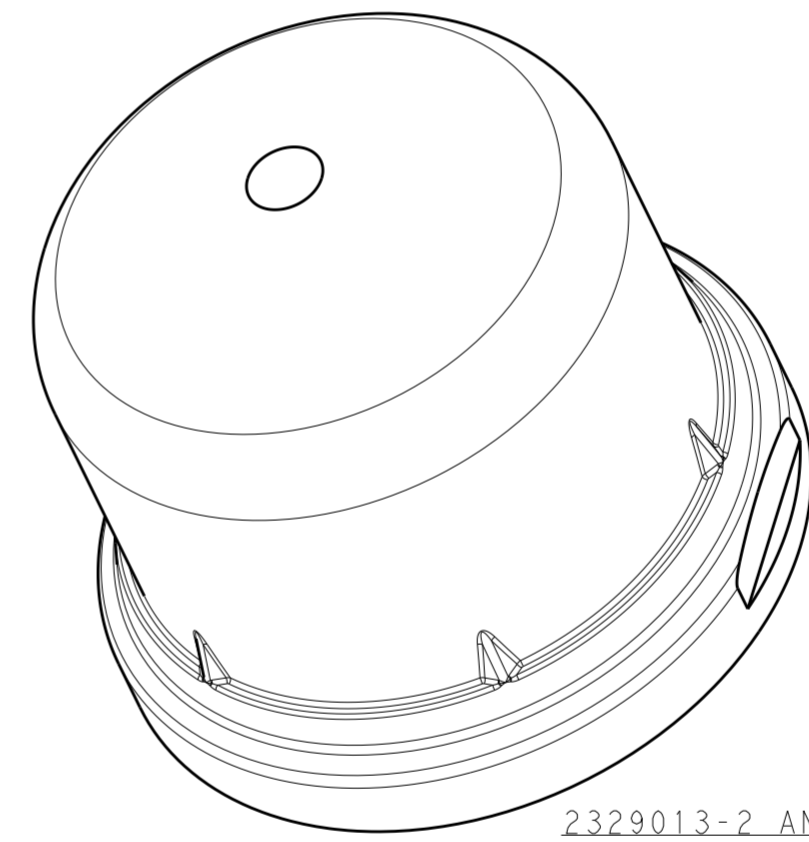

2329013-2 AND 1-2329013-2  
SHOWN  
SCALE 2:1

APPROX. LIGHT TRANSMISSION	COLOR	DIM X	PART NO.
26%	TRANSLUCENT GRAY	39.25	2-2329013-2
26%	TRANSLUCENT GRAY	24.25	2-2329013-1
78%	TRANSPARENT CLEAR	39.25	1-2329013-2
78%	TRANSPARENT CLEAR	24.25	1-2329013-1
24%	TRANSPARENT SMOKE	39.25	2329013-2
24%	TRANSPARENT SMOKE	24.25	2329013-1

THIS DRAWING IS A CONTROLLED DOCUMENT.		DWN C. DAILY 10 JAN 2018	TE Connectivity		
		CHK M. STOLLER 10 JAN 2018			
DIMENSIONS: mm		TOLERANCES UNLESS OTHERWISE SPECIFIED: 0 PLC ± 1 PLC ±0.2 2 PLC ±0.10 3 PLC ± 4 PLC ± ANGLES ±1° FINISH -		NAME DOME, LUMAWISE ENDURANCE S, 40mm	
MATERIAL SEE TABLE		PRODUCT SPEC 108-133073 APPLICATION SPEC 114-133074		SIZE CAGE CODE DRAWING NO A200779 C-2329013	
		WEIGHT -		RESTRICTED TO REV B2	
		CUSTOMER DRAWING		SCALE 5:2 SHEET 1 OF 1	