



# FSA3230 — High-Speed USB2.0 / Mobile High-Definition Link (MHL™) with Negative Swing Audio

## Features

- Low On Capacitance: 6 pF / 6 pF MHL / USB (Typical)
- Low Power Consumption: 30  $\mu$ A Maximum
- Supports MHL Rev. 2.0
- MHL Data Rate: 4.0 Gbps
- Audio Swing: -1.5 V to +1.5 V (Typical)
- $V_{BUS}$  Powers Device with No  $V_{CC}$
- Packaged in 16-Lead UMLP (1.8 x 2.6 mm)
- Over-Voltage Tolerance (OVT) on all USB Ports, Up to 5.25 V without External Components

## Applications

- Cell Phones and Digital Cameras

## Description

The FSA3230 is a bi-directional, low-power, high-speed, 3:1, USB2.0, MHL™ and audio switch. Configured as a double-pole, triple-throw (DP3T) switch, it is optimized for switching between high- or full-speed USB, Mobile High-Definition Link sources (per MHL Rev. 2.0 specification) and negative swing capable audio. A Single-Pole, Double-Throw (SPDT) switch is provided for ID. This ID switch provides path to support On-The-Go (OTG) communication for the USB Path OR CBUS for the MHL Path.

The FSA3230 contains special circuitry on the switch I/O pins, for applications where the  $V_{CC}$  supply is powered off ( $V_{CC}=0$ ), that allows the device to withstand an over-voltage condition. This switch is designed to minimize current consumption even when the control voltage applied to the control pins is lower than the supply voltage ( $V_{CC}$ ). This is especially valuable in mobile applications, such as cell phones; allowing direct interface with the general-purpose I/Os of the baseband processor. Other applications include switching and connector sharing in portable cell phones, digital cameras, and notebook computers.

## Ordering Information

Part Number	Top Mark	Operating Temperature Range	Package
FSA3230UMX	LK	-40 to +85°C	16-Lead, Ultrathin Molded Leadless Package (UMLP), 1.8 x 2.6 mm

## Analog Symbol

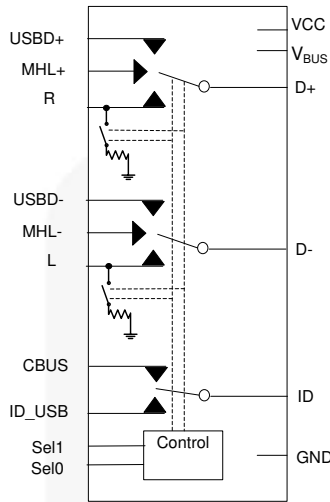

Figure 1. Analog Symbol

Table 1. Data Switch Select Truth Table

SEL1 <sup>(1)</sup>	SEL0 <sup>(1)</sup>	Shunt	Function
0	0	Enable	D+/D- connected to USB+/USB-; ID connected to ID_USB
0	1	Disable	D+/D- connected to R/L; ID connected to ID_USB
1	0	Enable	D+/D- connected to MHL+/MHL; ID connected to CBUS
1	1	Enable	D+/D- high impedance; ID Hi-Z

**Note:**

- Control inputs should never be left floating or unconnected. To guarantee default switch closure to the USB position, the SEL[0:1] pins should be tied to GND with a weak pull-down resistor (3 MΩ) to minimize static current draw.

## Pin Configuration

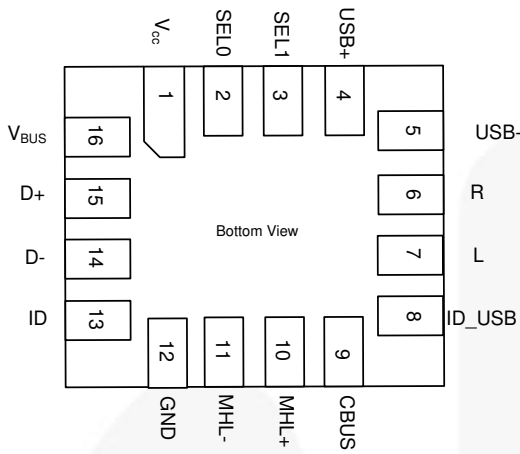

Figure 2. Pin Assignments

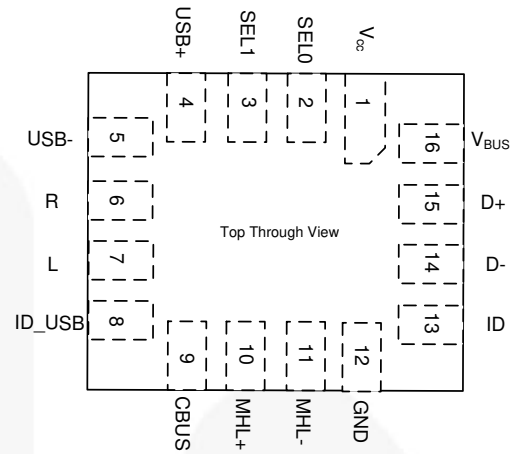

Figure 3. Top Through View

## Pin Definitions

Pin	Name	Description
1	V <sub>CC</sub>	V <sub>CC</sub> Supply
2	SEL0	Control Pin
3	SEL1	Control Pin
4	USB+	USB Differential Data (Positive)
5	USB-	USB Differential Data (Negative)
6	R	Audio R (Negative Swing)
7	L	Audio L (Negative Swing)
8	ID_USB	ID for USB Host
9	CBUS	CBUS for MHL Host
10	MHL+	MHL Differential Data (Positive)
11	MHL-	MHL Differential Data (Negative)
12	GND	Ground
13	ID	Common Data Path for ID
14	D-	Common Data Path D-
15	D+	Common Data Path D+
16	V <sub>BUS</sub>	V <sub>BUS</sub> Pin from Micro-USB Connector

## Absolute Maximum Ratings

Stresses exceeding the absolute maximum ratings may damage the device. The device may not function or be operable above the recommended operating conditions and stressing the parts to these levels is not recommended. In addition, extended exposure to stresses above the recommended operating conditions may affect device reliability. The absolute maximum ratings are stress ratings only.

Symbol	Parameter		Min.	Max.	Unit
$V_{CC}, V_{BUS}$	Supply Voltage		-0.5	6.0	V
$V_{CNTRL}$	DC Input Voltage (SEL[1:0]) <sup>(2)</sup>		-0.5	$V_{CC}$	V
$V_{SW}$	DC Switch I/O Voltage <sup>(2)</sup>	USB	-0.5	6.0	V
		MHL	-0.5	6.0	
		AUDIO	-2.0	3	V
		ID	-0.5	6.0	
$I_{IK}$	DC Input Diode Current		-50		mA
$I_{OUT}$	Switch DC Output Current (Continuous)	USB		60	mA
		MHL		60	mA
		AUDIO		60	mA
$I_{OUTPEAK}$	Switch DC Output Peak Current (Pulsed at 1ms Duration, <10% Duty Cycle)	USB		150	mA
		MHL		150	mA
		AUDIO		150	mA
$T_{STG}$	Storage Temperature		-65	+150	°C
MSL	Moisture Sensitivity Level: JEDEC J-STD-020A			1	
ESD	Human Body Model, JEDEC: JESD22-A114	All Pins		3.5	kV
	IEC 61000-4-2, Level 4, for D+/D- and $V_{CC}$ Pins <sup>(3)</sup>	Contact		8	
	IEC 61000-4-2, Level 4, for D+/D- and $V_{CC}$ Pins <sup>(3)</sup>	Air		15	
	Charged Device Model, JESD22-C101			2	

### Notes:

- The input and output negative ratings may be exceeded if the input and output diode current ratings are observed.  $V_{SW}$  refers to analog data switch paths (USB, MHL, and audio).
- Testing performed in a system environment using TVS diodes.

## Recommended Operating Conditions

The Recommended Operating Conditions table defines the conditions for actual device operation. Recommended operating conditions are specified to ensure optimal performance to the datasheet specifications. Fairchild does not recommend exceeding them or designing to Absolute Maximum Ratings.

Symbol	Parameter	Min.	Max.	Unit
V <sub>BUS</sub>	Supply Voltage Running from V <sub>BUS</sub> Voltage	4.2	5.25	V
V <sub>CC</sub>	Supply Voltage Running from V <sub>CC</sub>	2.5	4.5	V
t <sub>RAMP(VBUS)</sub>	Power Supply Slew Rate from V <sub>BUS</sub>	100	1000	μs/V
t <sub>RAMP(VCC)</sub>	Power Supply Slew Rate from V <sub>CC</sub>	100	1000	μs/V
Θ <sub>JA</sub>	Thermal Resistance, Junction to Ambient		283	C°/W
Θ <sub>JC</sub>	Thermal Resistance, Junction to Case		145	C°/W
V <sub>CNTRL</sub>	Control Input Voltage (SEL[1:0]) <sup>(4)</sup>	0	4.5	V
V <sub>SW(USB)</sub>	Switch I/O Voltage (USB and ID Switch Path)	-0.5	3.6	V
V <sub>SW(MHL)</sub>	Switch I/O Voltage (MHL Switch Path)	1.65	3.45	V
V <sub>SW(AUD)</sub>	Switch I/O Voltage (Audio Switch Path)	-1.5	3.0	V
T <sub>A</sub>	Operating Temperature	-40	+85	°C

### Note:

- The control inputs must be held HIGH or LOW; they must not float.

## DC Electrical Characteristics

All typical value are at T<sub>A</sub>=25°C unless otherwise specified.

Symbol	Parameter	Condition	V <sub>CC</sub> (V)	T <sub>A</sub> =- 40°C to +85°C			Unit
				Min.	Typ.	Max.	
V <sub>IK</sub>	Clamp Diode Voltage	I <sub>IN</sub> =-18 mA	2.5			-1.2	V
V <sub>IH</sub>	Control Input Voltage High SEL[1:0]		2.5 to 4.50	1.0			V
V <sub>IL</sub>	Control Input Voltage Low SEL[1:0]		2.5 to 4.50			0.5	V
I <sub>IN</sub>	Control Input Leakage SEL[1:0]	V <sub>SW(USB/MHL)</sub> =0 to 3.6 V, V <sub>SW(AUD)</sub> =0 to 3.0 V, V <sub>CNTRL</sub> =0 to V <sub>CC</sub>	4.5	-0.5		0.5	μA
I <sub>OZ(MHL)</sub>	Off-State Leakage for Open MHL Data Paths	V <sub>SW</sub> =1.65 ≤ MHL ≤ 3.45 V SEL[1:0]=V <sub>CC</sub>	4.5	-1		1	μA
I <sub>OZ(USB)</sub>	Off-State Leakage for Open USB Data Paths	V <sub>SW</sub> =0 ≤ USB ≤ 3.6 V SEL[1:0]=V <sub>CC</sub>	4.5	-0.5		0.5	μA
I <sub>OZ(ID)</sub>	Off-State Leakage for Open ID Data Paths	V <sub>SW</sub> =0 ≤ ID ≤ 3.6 V, SEL[1:0]=V <sub>CC</sub>	4.5	-1		1	μA
I <sub>CL(MHL)</sub>	On-State Leakage for Closed MHL Data Paths <sup>(5)</sup>	V <sub>SW</sub> =1.65 ≤ MHL ≤ 3.45 V, SEL0=GND, SEL1=V <sub>CC</sub> , Other Side of Switch Float	4.5	-0.75		0.75	μA
I <sub>CL(USB)</sub>	On-State Leakage for Closed USB Data Paths <sup>(5)</sup>	V <sub>SW</sub> =0 ≤ USB ≤ 3.6 V SEL[1:0]=GND, Other Side of Switch Float	4.5	-0.75		0.75	μA

Continued on the following page...

## DC Electrical Characteristics

All typical value are at  $T_A=25^{\circ}\text{C}$  unless otherwise specified.

Symbol	Parameter	Condition	V <sub>CC</sub> (V)	T <sub>A</sub> =- 40°C to +85°C			Unit
				Min.	Typ.	Max.	
I <sub>CL(AUD)</sub>	On-State Leakage for Closed <sup>(5)</sup> AUDIO Data Path	V <sub>SW</sub> =-1.5 ≤ R/L ≤ 1.5 V SEL1=GND, SEL0=V <sub>CC</sub> , Other Side of Switch Float	4.5	-1.0		1.0	μA
I <sub>CL(ID)</sub>	On-State Leakage for Closed ID Data Paths <sup>(5)</sup>	V <sub>SW</sub> =0 ≤ ID ≤ 3.6 V, SEL[1:0]=00, 01 or 10	4.5	-1.0		1.0	μA
I <sub>OFF</sub>	Power-Off Leakage Current (All I/O Ports)	V <sub>SW</sub> (USB/MHL)=0 to 3.6 V, V <sub>SW</sub> (AUD)=0 to 3.0 V, Figure 4	0	-1		1	μA
R <sub>ON(USB)</sub>	HS Switch On Resistance (USB to D Path)	V <sub>SW</sub> =0.4 V, I <sub>ON</sub> =-8 mA, SEL[1:0]=GND, Figure 5	2.5		3.9	6.5	Ω
R <sub>ON(MHL)</sub>	HS Switch On Resistance (MHL to D Path)	V <sub>SW</sub> =V <sub>CC</sub> -1050 mV, SEL0=GND, SEL1=V <sub>CC</sub> , I <sub>ON</sub> =-8 mA, Figure 5	2.5		5		Ω
R <sub>ON(Audio)</sub>	Audio Switch On Resistance (R/L Path)	V <sub>SW</sub> =-1.5 V to 1.5 V, SEL1=GND, SEL0=V <sub>CC</sub> , I <sub>ON</sub> =-24 mA, Figure 5	2.5		4		Ω
R <sub>ON(ID)</sub>	ID Switch On Resistance (ID_USB or CBUS to D Path)	V <sub>SW</sub> =3 V, I <sub>ON</sub> =-8 mA, SEL[1:0]=00, 01 or 10, Figure 5	2.5		12		Ω
ΔR <sub>ON(MHL)</sub>	Difference in R <sub>ON</sub> Between MHL Positive-Negative	V <sub>SW</sub> =V <sub>CC</sub> -1050 mV, SEL0=GND, SEL1=V <sub>CC</sub> , I <sub>ON</sub> =-8 mA, Figure 5	2.5		0.03		Ω
ΔR <sub>ON(USB)</sub>	Difference in R <sub>ON</sub> Between USB Positive-Negative	V <sub>SW</sub> =0.4 V, I <sub>ON</sub> =-8 mA, SEL[1:0]=GND, Figure 5	2.5		0.18		Ω
ΔR <sub>ON(ID)</sub>	Difference in R <sub>ON</sub> Between ID_USB and CBUS	V <sub>SW</sub> =3 V, I <sub>ON</sub> =-8 mA, SEL[1:0]=00, 01 or 10, Figure 5	2.5		0.4		Ω
R <sub>ONF(MHL)</sub>	Flatness for R <sub>ON</sub> MHL Path	V <sub>SW</sub> =1.65 to 3.45 V, SEL0=GND, SEL1=V <sub>CC</sub> , I <sub>ON</sub> =-8 mA, Figure 5	2.5		1		Ω
R <sub>ONFA(AUDIO)</sub>	Flatness for R <sub>ON</sub> Audio Path	V <sub>SW</sub> =-1.5 V to 1.5 V, SEL1=GND, SEL0=V <sub>CC</sub> , I <sub>ON</sub> =-24 mA, Figure 5	2.5		0.1		Ω
R <sub>SH</sub>	Shunt Resistance		3.6		125	200	Ω
I <sub>CC</sub>	Quiescent Current	V <sub>CNTRL</sub> =0 or 4.5 V, I <sub>OUT</sub> =0	4.5			30	μA
I <sub>CCT</sub>	Delta Increase in Quiescent Current per Control Pin	V <sub>CNTRL</sub> =1.65 V, I <sub>OUT</sub> =0	4.5			18	μA
		V <sub>CNTRL</sub> =2.5 V, I <sub>OUT</sub> =0	4.5			10	

**Note:**

5. For this test, the data switch is closed with the respective switch pin floating.

## AC Electrical Characteristics

All typical value are at  $T_A=25^\circ\text{C}$  unless otherwise specified.

Symbol	Parameter	Condition	$V_{CC}$ (V)	$T_A=-40^\circ\text{C}$ to $+85^\circ\text{C}$			Unit
				Min.	Typ.	Max.	
$t_{ONUSB}$	USB Turn-On Time, SEL[1:0] to Output	$R_L=50\ \Omega$ , $C_L=5\text{pF}$ , $V_{SW(USB)}=0.8\text{ V}$ , $V_{SW(MHL)}=3.3\text{ V}$ , $V_{SW(AUD)}=1.5\text{ V}$ , Figure 6, Figure 7	2.5 to 3.6		445	600	ns
$t_{OFFUSB}$	USB Turn-Off Time, SEL[1:0] to Output	$R_L=50\ \Omega$ , $C_L=5\text{ pF}$ , $V_{SW(USB)}=0.8\text{ V}$ , $V_{SW(MHL)}=3.3\text{ V}$ , $V_{SW(AUD)}=1.5\text{ V}$ , Figure 6, Figure 7	2.5 to 3.6		445	600	ns
$t_{ONAUD}$	AUDIO Turn-On Time, SEL[1:0] to Output	$R_L=50\ \Omega$ , $C_L=5\text{ pF}$ , $V_{SW(USB)}=0.8\text{ V}$ , $V_{SW(MHL)}=3.3\text{ V}$ , $V_{SW(AUD)}=1.5\text{ V}$ , Figure 6, Figure 7	2.5 to 3.6		445	600	ns
$t_{OFFAUD}$	AUDIO Turn-Off Time, SEL[1:0] to Output	$R_L=50\ \Omega$ , $C_L=5\text{ pF}$ , $V_{SW(USB)}=0.8\text{ V}$ , $V_{SW(MHL)}=3.3\text{ V}$ , $V_{SW(AUD)}=1.5\text{ V}$ , Figure 6, Figure 7	2.5 to 3.6		445	600	ns
$t_{ONMHL}$	MHL Turn-On Time, SEL[1:0] to Output	$R_L=50\ \Omega$ , $C_L=5\text{ pF}$ , $V_{SW(USB)}=0.8\text{ V}$ , $V_{SW(MHL)}=3\text{ V}$ , $V_{SW(AUD)}=1.5\text{ V}$ , Figure 6, Figure 7	2.5 to 3.6		445	600	ns
$t_{OFFMHL}$	MHL Turn-Off Time, SEL[1:0] to Output	$R_L=50\ \Omega$ , $C_L=5\text{ pF}$ , $V_{SW(USB)}=0.8\text{ V}$ , $V_{SW(MHL)}=3.3\text{ V}$ , $V_{SW(AUD)}=1.5\text{ V}$ , Figure 6, Figure 7	2.5 to 3.6		445	600	ns
$t_{PD}$	Propagation Delay <sup>(6)</sup>	$C_L=5\text{ pF}$ , $R_L=50\ \Omega$ , Figure 6, Figure 8	2.5 to 3.6		0.25		ns
$t_{BBM}$	Break-Before-Make <sup>(6)</sup>	$R_L=50\ \Omega$ , $C_L=5\text{ pF}$ , $V_{AUD}=1.5\text{ V}$ , $V_{MHL}=3.3\text{ V}$ , $V_{USB}=0.8\text{ V}$ , Figure 9	2.5 to 3.6		350		ns
$O_{IRR(MHL)}$	Off Isolation <sup>(6)</sup>	$V_S=1\text{ V}_{pk-pk}$ , $R_L=50\ \Omega$ , $f=240\text{ MHz}$ , Figure 10	2.5 to 3.6		-41		dB
$O_{IRR(USB)}$		$V_S=400\text{ mV}_{pk-pk}$ , $R_L=50\ \Omega$ , $f=240\text{ MHz}$ , Figure 10	2.5 to 3.6		-38		dB
$Xtalk_{MHL}$	Non-Adjacent Channel Crosstalk <sup>(6)</sup>	$V_S=1\text{ V}_{pk-pk}$ , $R_L=50\ \Omega$ , $f=240\text{ MHz}$ , Figure 11	2.5 to 3.6		-37		dB
$Xtalk_{USB}$		$V_S=400\text{ mV}_{pk-pk}$ , $R_L=50\ \Omega$ , $f=240\text{ MHz}$ , Figure 11	2.5 to 3.6		-34		dB
$Xtalk_{AUD}$		$V_S=100\text{ mV}_{RMS}$ , $R_L=32\ \Omega$ , $f=20\text{ kHz}$ , Figure 11	2.5 to 3.6		-70		dB
THD	Total Harmonic Distortion	$R_T=32\ \Omega$ , $V_{SW}=2\text{ V}_{pk-pk}$ , $f=20\text{ Hz}$ to $20\text{ kHz}$ , $V_{BIAS}=0\text{ V}$	2.5		0.03		%
BW	$S_{DD21}$ Differential -3db Bandwidth <sup>(6)</sup>	$V_{IN}=1\text{ V}_{pk-pk}$ , Common Mode Voltage= $V_{CC} - 1.1\text{ V}$ , MHL Path, $R_L=50\ \Omega$ , $C_L=0\text{ pF}$ , Figure 12	2.5 to 3.6		2.0		GHz
		$V_{IN}=400\text{ mV}_{pk-pk}$ , Common Mode Voltage= $0.2\text{ V}$ , USB Path, $R_L=50\ \Omega$ , $C_L=0\text{ pF}$ , Figure 12			2.0		
		AUDIO Path, $R_L=50\ \Omega$ , $C_L=0\text{ pF}$			50		MHz

**Note:**

6. Guaranteed by characterization.

## USB High-Speed AC Electrical Characteristics

All typical value are at  $T_A=25^{\circ}\text{C}$  unless otherwise specified.

Symbol	Parameter	Condition	$V_{CC}$ (V)	Typ.	Unit
$t_{SK(P)}$	Skew of Opposite Transitions of the Same Output <sup>(7)</sup>	$C_L=5\text{ pF}$ , $R_L=50\ \Omega$ , Figure 13	3.0 to 3.6	3	ps
$t_J$	Total Jitter <sup>(7)</sup>	$R_L=50\ \Omega$ , $C_L=5\text{ pF}$ , $t_R=t_F=500\text{ ps}$ (10-90%) at 480 Mbps, PN7	3.0 to 3.6	15	ps

**Note:**

7. Guaranteed by characterization.

## MHL AC Electrical Characteristics

All typical value are at  $T_A=25^{\circ}\text{C}$  unless otherwise specified.

Symbol	Parameter	Condition	$V_{CC}$ (V)	Typ.	Unit
$t_{SK(P)}$	Skew of Opposite Transitions of the Same Output <sup>(8)</sup>	$R_{PU}=50\ \Omega$ to $V_{CC}$ , $C_L=0\text{ pF}$	3.0 to 3.6	3	ps
$t_J$	Total Jitter <sup>(8)</sup>	$f=2.25\text{ Gbps}$ , PN7, $R_{PU}=50\ \Omega$ to $V_{CC}$ , $C_L=0\text{ pF}$	3.0 to 3.6	26	ps

**Note:**

8. Guaranteed by characterization.

## Capacitance

All typical value are at  $T_A=25^{\circ}\text{C}$  unless otherwise specified.

Symbol	Parameter	Condition	Typ.	Unit
$C_{IN}$	Control Pin Input Capacitance <sup>(9)</sup>	$V_{CC}=0\text{ V}$ , $f=1\text{ MHz}$	1.5	pF
$C_{ON(USB)}$	USB Path On Capacitance <sup>(9)</sup>	$V_{CC}=3.3\text{ V}$ , $f=240\text{ MHz}$ , Figure 14	6.0	
$C_{OFF(USB)}$	USB Path Off Capacitance <sup>(9)</sup>	$V_{CC}=3.3\text{ V}$ , $f=240\text{ MHz}$ , Figure 15	2.5	
$C_{ON(MHL)}$	MHL Path On Capacitance <sup>(9)</sup>	$V_{CC}=3.3\text{ V}$ , $f=240\text{ MHz}$ , Figure 14	6.0	
$C_{OFF(MHL)}$	MHL Path Off Capacitance <sup>(9)</sup>	$V_{CC}=3.3\text{ V}$ , $f=240\text{ MHz}$ , Figure 15	2.5	
$C_{ON(AUD)}$	Audio Path On Capacitance <sup>(9)</sup>	$V_{CC}=3.3\text{ V}$ , $f=1\text{ MHz}$ , Figure 14	10	
$C_{OFF(AUD)}$	Audio Path Off Capacitance <sup>(9)</sup>	$V_{CC}=3.3\text{ V}$ , $f=1\text{ MHz}$ , Figure 15	2.5	
$C_{ON(ID)}$	ID Path On Capacitance <sup>(9)</sup>	$V_{CC}=3.3\text{ V}$ , $f=1\text{ MHz}$ , Figure 14	3.5	
$C_{OFF(ID)}$	ID Path Off Capacitance <sup>(9)</sup>	$V_{CC}=3.3\text{ V}$ , $f=1\text{ MHz}$ , Figure 15	1.5	

**Note:**

9. Guaranteed by characterization.



**Test Diagrams**

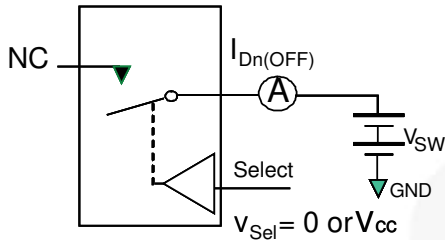

\*\*Each switch port is tested separately

**Figure 4. Off Leakage**

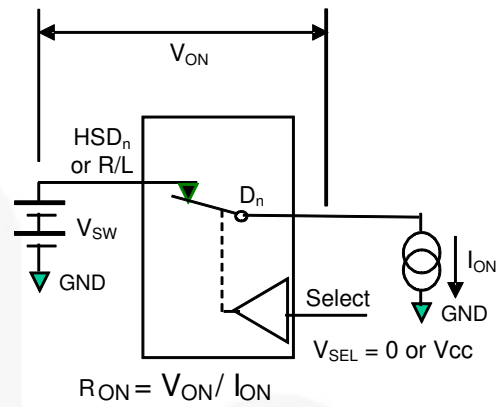

**Figure 5. On Resistance**

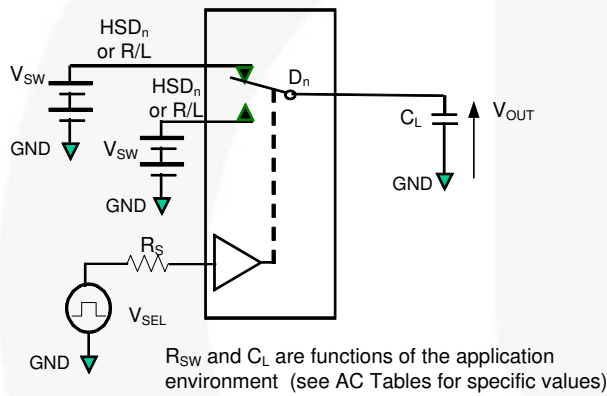

**Figure 6. AC Test Circuit Load**

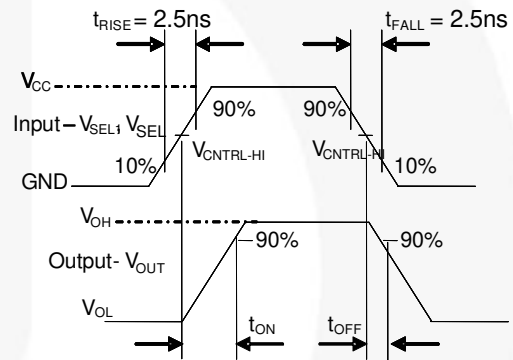

**Figure 7. Turn-On / Turn-Off Waveforms**

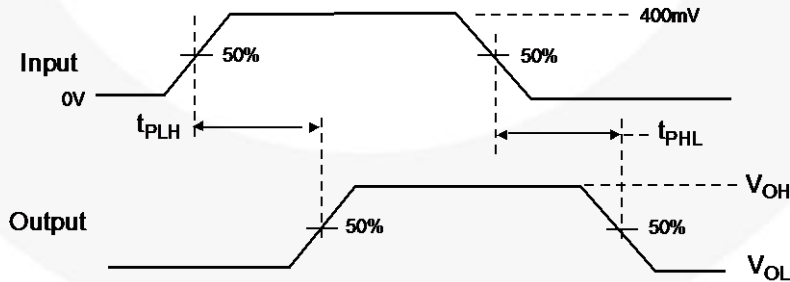
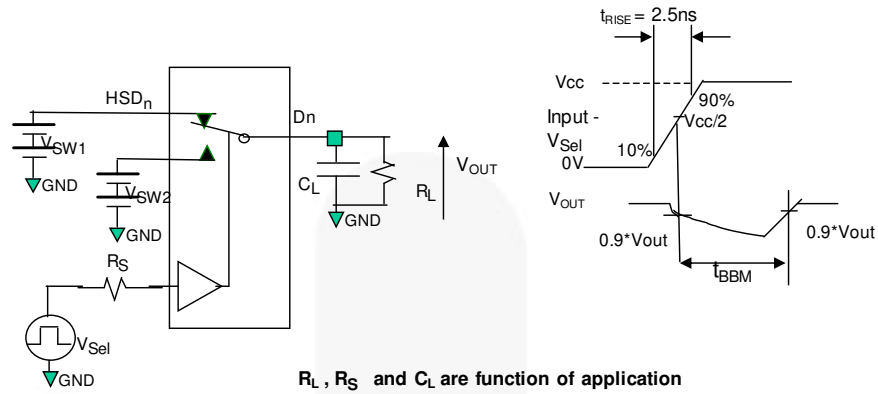

**Figure 8. Propagation Delay ( $t_{RTF} = 500ps$ )**

**Note:**

10. HSD<sub>n</sub> refers to the high-speed data USB or MHL paths.

## Test Diagrams



$R_L$ ,  $R_S$  and  $C_L$  are function of application environment (see AC Tables for specific values)  
 $C_L$  includes test fixture and stray capacitance

**Figure 9. Break-Before-Make Interval Timing**

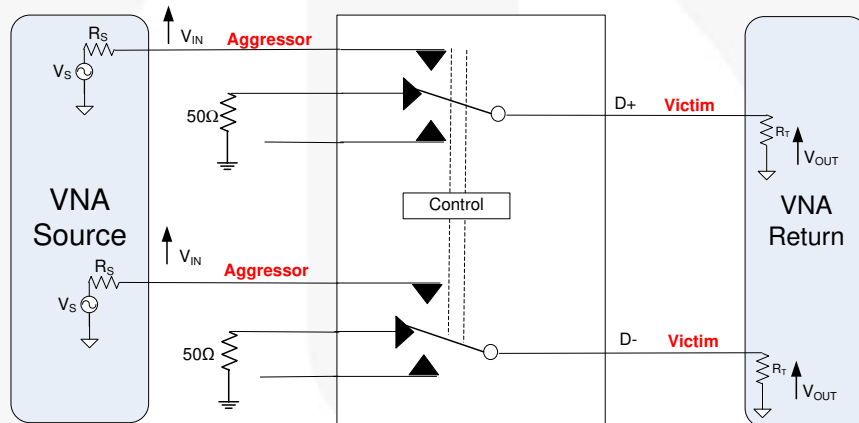

$V_S$ ,  $R_S$  and  $R_T$  are functions of the application environment (see AC/DC Tables for values).  
 Off Isolation =  $20 \text{ Log } (V_{OUT} - V_{IN})$

**Figure 10. Channel Off Isolation (SDD21)**

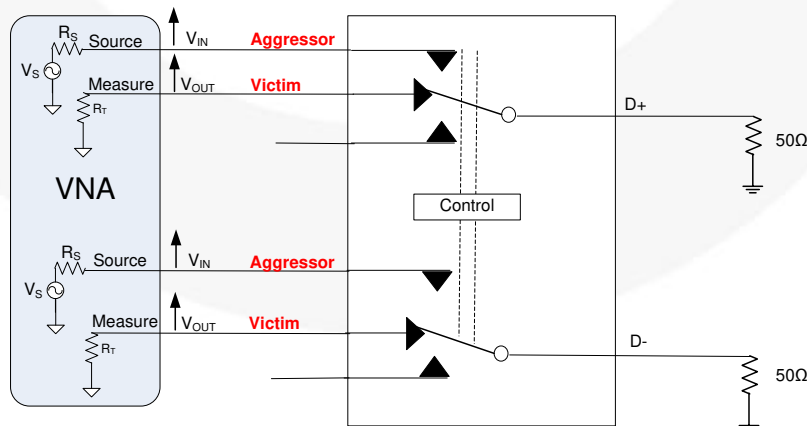

$V_S$ ,  $R_S$  and  $R_T$  are functions of the application environment (see AC/DC Tables for values).  
 Off Isolation =  $20 \text{ Log } (V_{OUT} - V_{IN})$

**Figure 11. Non-Adjacent Channel-to-Channel Crosstalk (SDD21)**

### Test Diagrams

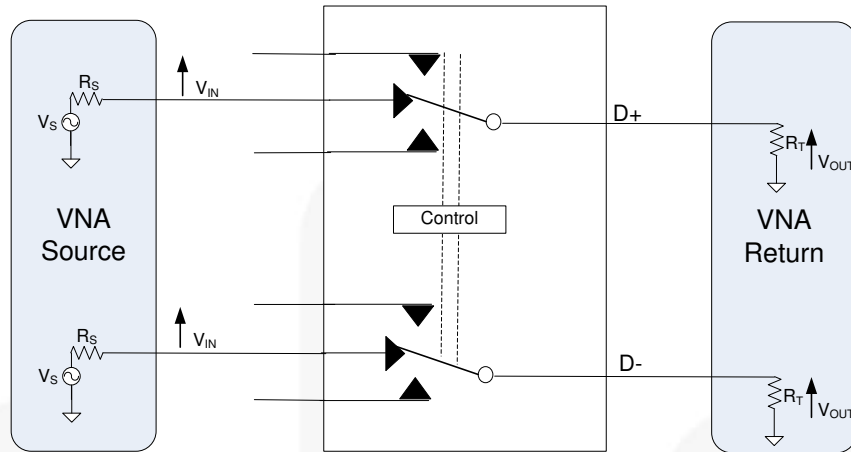

$V_S$ ,  $R_S$  and  $R_T$  are functions of the application environment (see AC/DC Tables for values).

**Figure 12. Insertion Loss (SDD21)**

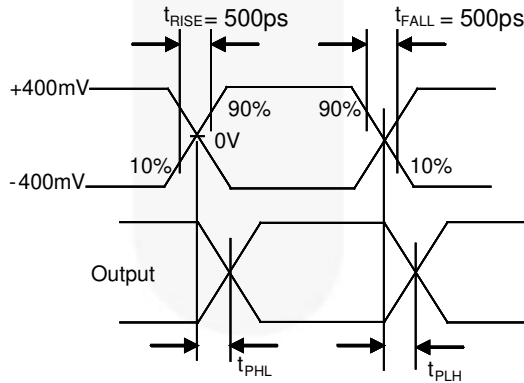

**Figure 13. Intra-Pair Skew Test  $t_{SK(P)}$**

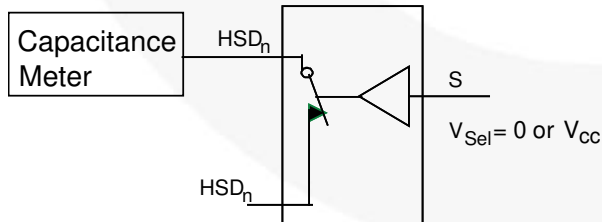

**Figure 14. Channel On Capacitance**

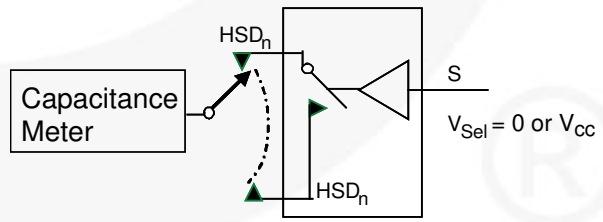

**Figure 15. Channel Off Capacitance**

## Functional Description

### Insertion Loss

One of the key factors for using the FSA3230 in mobile digital video applications is the small amount of insertion loss experienced by the received signal as it passes through the switch. This results in minimal degradation of the received eye. One of the ways to measure the quality of the high data rate channels is using balanced ports and four-port differential S-parameter analysis, particularly SDD21.

Bandwidth is measured using the S-parameter SDD21 methodology.



Figure 16. MHL Path SDD21 Insertion Loss Curve



Figure 17. USB Path SDD21 Insertion Loss Curve

### Typical Applications

Figure 18 shows the FSA3230 utilizing the  $V_{BUS}$  from the micro-USB connection. The 3 M $\Omega$  resistors are used

to ensure, for manufacturing test via the micro-USB connector, that the FSA3230 configures for connectivity to the baseband or application processor. Figure 19 shows the configuration for the FSA3230 “self powered” by battery only.

### Switch Power Operation

In normal operation, the FSA3230 is powered from the  $V_{CC}$  pin, which typically is derived from a regulated power management device. In special circumstances, such as production test or system firmware upgrade, the device can be powered from the  $V_{BUS}$  pin. If both  $V_{CC}$  and  $V_{BUS}$  pins are present,  $V_{CC}$  is selected as the power source and  $V_{BUS}$  is ignored (see Table 2).

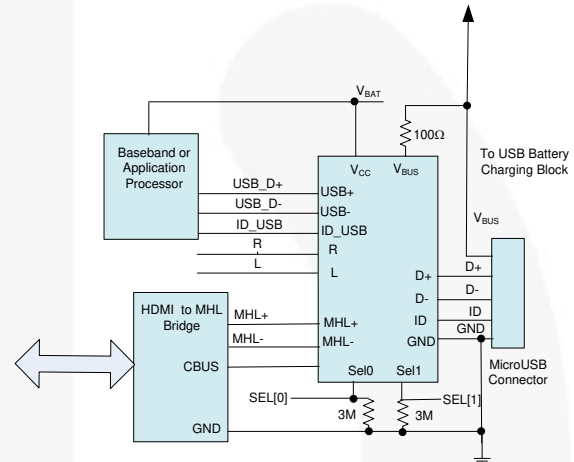

Figure 18. Application Using  $V_{BUS}$

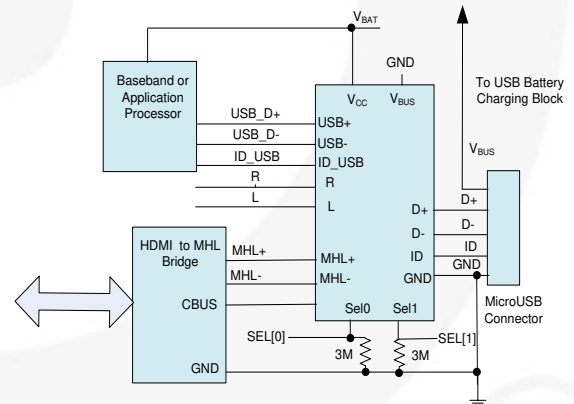
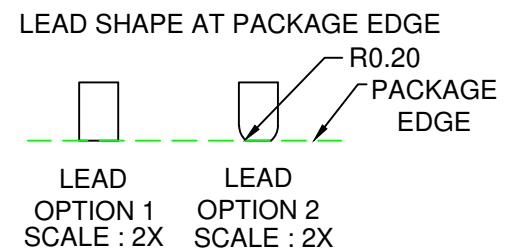
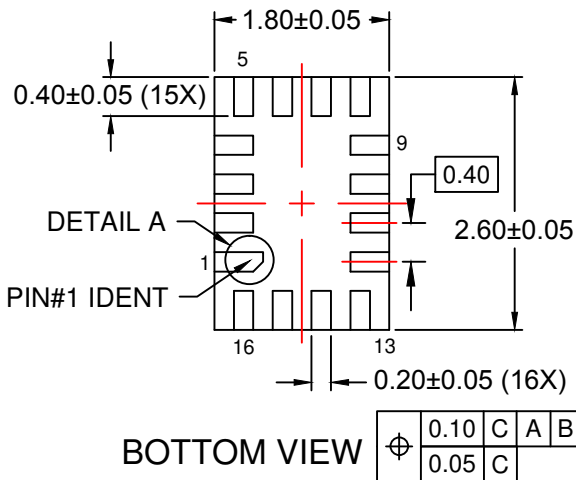
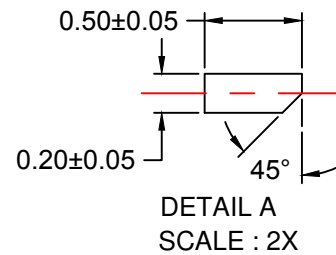
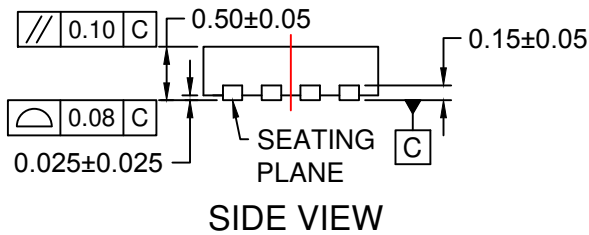
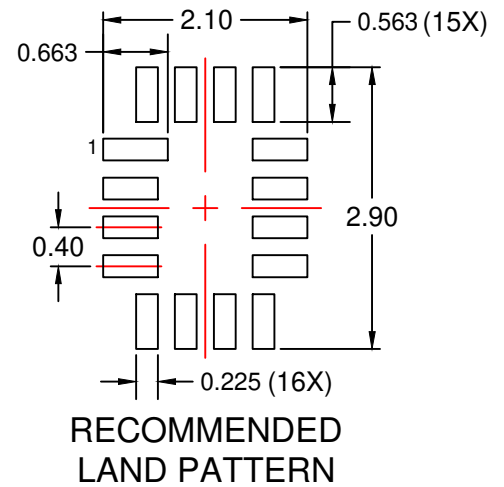
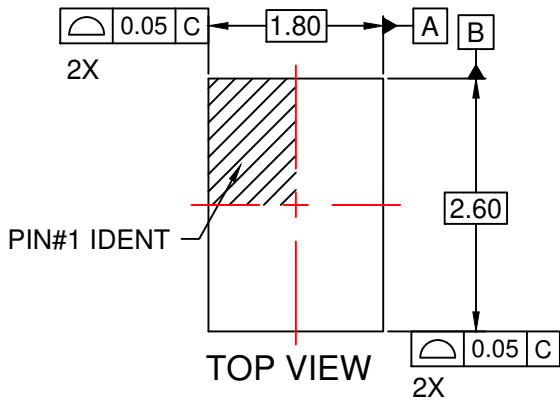

Figure 19. “Self-Powered” Application Using  $V_{BAT}$

Table 2. Switch Power Selection Truth Table

$V_{CC}$	$V_{BUS}$	Switch Power Source
0	0	No Switch Power, Switch Paths High Z
0	1	$V_{BUS}$
1	0	$V_{CC}$
1	1	$V_{CC}$

Description	Nominal Values for MKT-UMLP16A Rev5 (mm)
Overall Height	0.50
Package Standoff	0.012
Lead Thickness	0.15
Lead Width	0.20
Lead Length	0.40
Lead Pitch	0.40
Body Length (Y)	Min: 2.50, Nom: 2.60, Max: 2.70
Body Width (X)	Min: 1.70, Nom: 1.80, Max: 1.90



**NOTES:**





- A. PACKAGE DOES NOT FULLY CONFORM TO JEDEC STANDARD.
- B. DIMENSIONS ARE IN MILLIMETERS.
- C. DIMENSIONS AND TOLERANCES PER ASME Y14.5M, 2009.
- D. LAND PATTERN RECOMMENDATION IS EXISTING INDUSTRY LAND PATTERN.
- E. DRAWING FILENAME: MKT-UMLP16Arev5.
- F. TERMINAL SHAPE MAY VARY ACCORDING TO PACKAGE SUPPLIER, SEE TERMINAL SHAPE VARIANTS.





**TRADEMARKS**

The following includes registered and unregistered trademarks and service marks, owned by Fairchild Semiconductor and/or its global subsidiaries, and is not intended to be an exhaustive list of all such trademarks.

- |   |  |   |   |
|---|--|---|---|
| AccuPower™  | F-PFS™   | OPTOPLANAR®   |  |
| AttitudeEngine™   | FRFET®   |  | TinyBoost®  |
| Awinda®   | Global Power Resource <sup>SM</sup>            | PowerTrench®  | TinyBuck®   |
| AX-CAP®*  | GreenBridge™                                   | PowerXS™  | TinyCalc™   |
| BitSiC™   | Green FPS™                                     | Programmable Active Droop™  | TinyLogic®  |
| Build it Now™   | Green FPS™ e-Series™                           | QFET®   | TINYOPTO™   |
| CorePLUS™   | Gmax™  | QS™   | TinyPower™  |
| CorePOWER™  | GTO™   | Quiet Series™   | TinyPWM™  |
| CROSSVOL™   | IntelliMAX™                                    | RapidConfigure™   | TinyWire™   |
| CTL™  | ISOPLANAR™                                     |  | TranSiC™  |
| Current Transfer Logic™   | Making Small Speakers Sound Louder and Better™ | Saving our world, 1mW/W/kW at a time™   | TriFault Detect™  |
| DEUXPEED®   | MegaBuck™                                      | SignalWise™   | TRUECURRENT®*   |
| Dual Cool™  | MICROCOUPLER™                                  | SmartMax™   | μSerDes™  |
| EcoSPARK®   | MicroFET™                                      | SMART START™  |  |
| EfficientMax™   | MicroPak™                                      | Solutions for Your Success™   | UHC®  |
| ESBC™   | MicroPak2™                                     | SPM®  | Ultra FRFET™  |
|  | MillerDrive™                                   | STEALTH™  | UniFET™   |
| Fairchild®  | MotionMax™                                     | SuperFET®   | VCX™  |
| Fairchild Semiconductor®  | MotionGrid®                                    | SuperSOT™-3   | VisualMax™  |
| FACT Quiet Series™  | MTi®   | SuperSOT™-6   | VoltagePlus™  |
| FACT®   | MTX®   | SuperSOT™-8   | XS™   |
| FastvCore™  | MVN®   | SupreMOS®   | Xsens™  |
| FETBench™   | mWSaver®                                       | SyncFET™  | 仙童®   |
| FPS™  | OptoHiT™                                       | Sync-Lock™  |   |
|   | OPTOLOGIC®                                     |   |   |

\* Trademarks of System General Corporation, used under license by Fairchild Semiconductor.

**DISCLAIMER**

FAIRCHILD SEMICONDUCTOR RESERVES THE RIGHT TO MAKE CHANGES WITHOUT FURTHER NOTICE TO ANY PRODUCTS HEREIN TO IMPROVE RELIABILITY, FUNCTION, OR DESIGN. TO OBTAIN THE LATEST, MOST UP-TO-DATE DATASHEET AND PRODUCT INFORMATION, VISIT OUR WEBSITE AT [HTTP://WWW.FAIRCHILDSEMI.COM](http://www.fairchildsemi.com). FAIRCHILD DOES NOT ASSUME ANY LIABILITY ARISING OUT OF THE APPLICATION OR USE OF ANY PRODUCT OR CIRCUIT DESCRIBED HEREIN; NEITHER DOES IT CONVEY ANY LICENSE UNDER ITS PATENT RIGHTS, NOR THE RIGHTS OF OTHERS. THESE SPECIFICATIONS DO NOT EXPAND THE TERMS OF FAIRCHILD'S WORLDWIDE TERMS AND CONDITIONS, SPECIFICALLY THE WARRANTY THEREIN, WHICH COVERS THESE PRODUCTS.

**AUTHORIZED USE**

Unless otherwise specified in this data sheet, this product is a standard commercial product and is not intended for use in applications that require extraordinary levels of quality and reliability. This product may not be used in the following applications, unless specifically approved in writing by a Fairchild officer: (1) automotive or other transportation, (2) military/aerospace, (3) any safety critical application – including life critical medical equipment – where the failure of the Fairchild product reasonably would be expected to result in personal injury, death or property damage. Customer's use of this product is subject to agreement of this Authorized Use policy. In the event of an unauthorized use of Fairchild's product, Fairchild accepts no liability in the event of product failure. In other respects, this product shall be subject to Fairchild's Worldwide Terms and Conditions of Sale, unless a separate agreement has been signed by both Parties.

**ANTI-COUNTERFEITING POLICY**

Fairchild Semiconductor Corporation's Anti-Counterfeiting Policy. Fairchild's Anti-Counterfeiting Policy is also stated on our external website, [www.fairchildsemi.com](http://www.fairchildsemi.com), under Terms of Use

Counterfeiting of semiconductor parts is a growing problem in the industry. All manufacturers of semiconductor products are experiencing counterfeiting of their parts. Customers who inadvertently purchase counterfeit parts experience many problems such as loss of brand reputation, substandard performance, failed applications, and increased cost of production and manufacturing delays. Fairchild is taking strong measures to protect ourselves and our customers from the proliferation of counterfeit parts. Fairchild strongly encourages customers to purchase Fairchild parts either directly from Fairchild or from Authorized Fairchild Distributors who are listed by country on our web page cited above. Products customers buy either from Fairchild directly or from Authorized Fairchild Distributors are genuine parts, have full traceability, meet Fairchild's quality standards for handling and storage and provide access to Fairchild's full range of up-to-date technical and product information. Fairchild and our Authorized Distributors will stand behind all warranties and will appropriately address any warranty issues that may arise. Fairchild will not provide any warranty coverage or other assistance for parts bought from Unauthorized Sources. Fairchild is committed to combat this global problem and encourage our customers to do their part in stopping this practice by buying direct or from authorized distributors.

**PRODUCT STATUS DEFINITIONS**

**Definition of Terms**

Datasheet Identification	Product Status	Definition
Advance Information	Formative / In Design	Datasheet contains the design specifications for product development. Specifications may change in any manner without notice.
Preliminary	First Production	Datasheet contains preliminary data; supplementary data will be published at a later date. Fairchild Semiconductor reserves the right to make changes at any time without notice to improve design.
No Identification Needed	Full Production	Datasheet contains final specifications. Fairchild Semiconductor reserves the right to make changes at any time without notice to improve the design.
Obsolete	Not In Production	Datasheet contains specifications on a product that is discontinued by Fairchild Semiconductor. The datasheet is for reference information only.

Rev. I77