



## SPECIFICATION

FOR ELECTRO-MAGNET DYNAMIC MICROPHONE

TOTAL PAGE 06 [www.bestargroups.com](http://www.bestargroups.com) RoHS

Customer		Model Name	BCM9750ULF-47-J50 LF
Customer P/N		Product No.	195149
Date	7 Oct.2014	Issue No.	BS/TEM01.450A
Page	01 of 07	Issue Date	2014.10.07

### Approval:

- 1.Characteristics
- 2.Drawing
- 3.Measurement Circuit
- 4.Reliability Test
- 5.Packing
- 6.History change record

Drawn by	Checked by	Approved by	Customer approved

### **BESTAR HOLDING CO.,LTD**

No.199 HuangHe West Road.New district,ChangZhou,JiangSu Province,P.R.China

**Tel:** +86 519 88222567 **Fax:** +86 519 88222551

**[www.bestargroups.com](http://www.bestargroups.com)** [info@be-star.com](mailto:info@be-star.com) **<http://www.bestargroups.com>**

# BCM9750ULF-47-J50 LF

## 1. Characteristics

Test Condition (Vs=2V RL=2.2K Ω Ta=20°C R.H.=65%)

No.	Item	Specifications
1	Sensitivity	-47 ± 3dB(0dB=1V/Pa,1kHz)
2	Frequency Response	100Hz-10kHz
3	Current Consumption	0.5mA Max.
4	Directional	omnidirectional
5	S/N Ratio	more than 58dB
6	Standard Operating Voltage	2V
7	Operating Voltage	1V~10V
8	Sensitivity reduction	within -3dB at 1.5V
9	Distortion	2%
10	Storage Temperature	-40°C to +70°C
11	Operating Temperature	-30°C to +60°C

### ★Frequency Resonse Curve

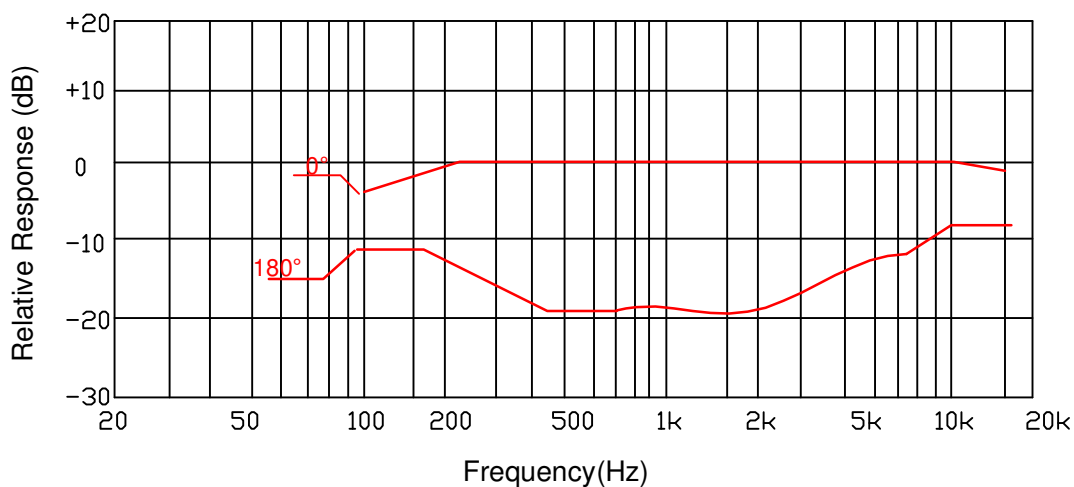

This print and information there in are proprietary to Bestar Holding Co., Ltd. and shall not be used in whole or in part without its written content.

				Date:	2014.10.07	BCM9750ULF-47-J50 LF
				Drawn by:	王焕焕	
A	2014.10.07	王焕焕		Checked by:	徐波	Microphone
Rev.	Date	Drawn	Note	Approved by:	徐金国	
BESTAR HOLDING CO.,LTD						DRG NO: BS/TEM01.450A
www.bestargroups.com wu@be-star.com						Page: 2 of 7

# BCM9750ULF-47-J50 LF

## ★Angular Response

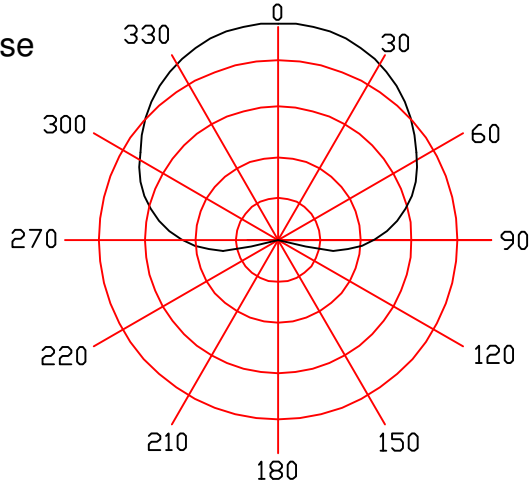

## 2. Drawing

filter

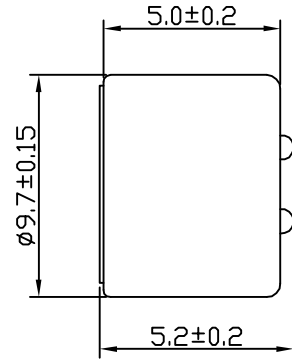
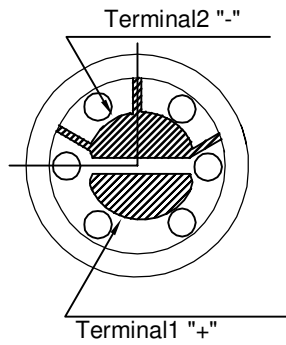
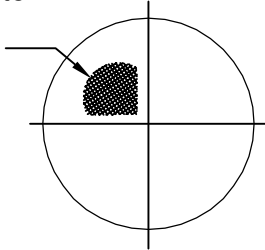

Unit: mm

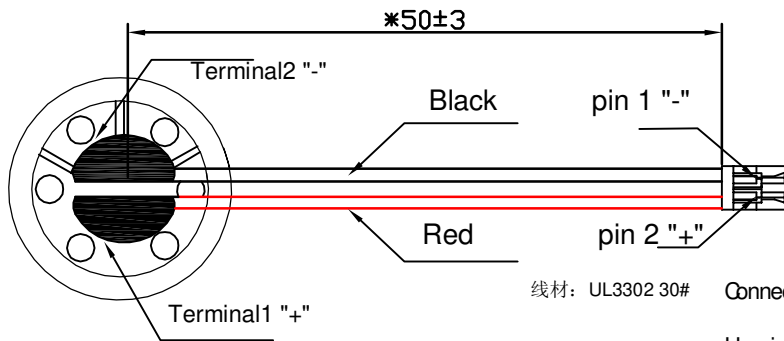

线材: UL3302 30#    Connect or: JST  
 Hbusi ng: GFR 02V-S  
 Ori n p i ns: SSL-002T-P0.2

This print and information there in are proprietary to Bestar Holding Co., Ltd. and shall not be used in whole or in part without its written content

				Date:	2014.10.07	BCM9750ULF-47-J50 LF
				Drawn by:	王焕焕	
A	2014.10.07	王焕焕		Checked by:	徐波	Microphone
Rev.	Date	Drawn	Note	Approved by:	徐金国	
BESTAR HOLDING CO.,LTD						DRG NO: BS/TEM01.450A
www.bestargroups.com    wu@be-star.com						Page:3 of 7

# BCM9750ULF-47-J50 LF

## 3. Measurement Circuit:

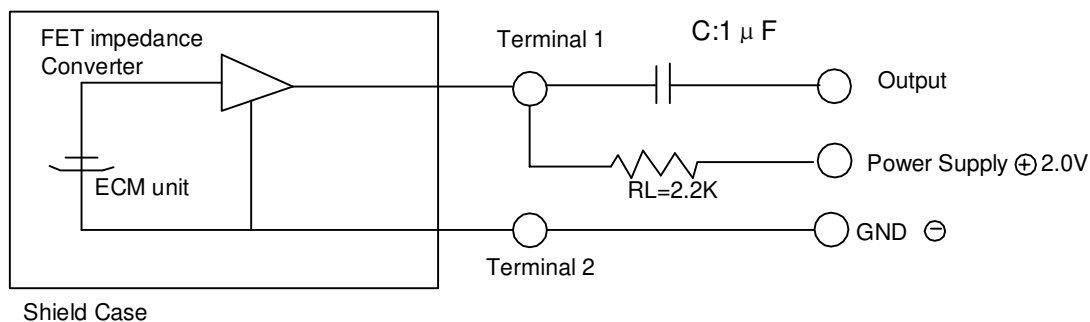

This print and information there in are proprietary to Bestar Holding Co., Ltd. and shall not be used in whole or in part without its written consent

				Date:	2014.10.07	BCM9750ULF-47-J50 LF
				Drawn by:	王焕焕	
A	2014.10.07	王焕焕		Checked by:	徐波	Microphone
Rev.	Date	Drawn	Note	Approved by:	徐金国	
BESTAR HOLDING CO.,LTD						DRG NO: BS/TEM01.450A
www.bestargroups.com wu@be-star.com						Page:4 of 7

# BCM9750ULF-47-J50 LF

## 4. Reliability Test

- 4.1 High temp.life test
  - Temperature + 70 °C
  - Duration 100hrs
- 4.2 Low temp.life test
  - Temperature -40 °C
  - Duration 100hrs
- 4.3 Temperature cycle test
  - Cycles 10

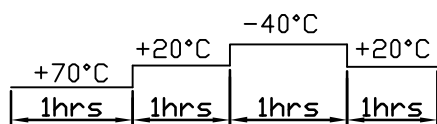

- 4.4 Humidity Test
  - Temperature +40 °C
  - Relative Humidity 90~95%
  - Duration 48hrs

Tests above should be measured after leaving normal temperature for 6hrs.

- 4.5 Vibration Test
  - Vibration Frequency 10~55Hz
  - Amplitude 1.52mm/min
  - Direction 3(x.y&z)
  - Duration 2hrs each cycle(total 6 hrs)
- 4.6 Drop test
  - Height 1m
  - (Dropped to 20mm thick hardwood board without packing.)
  - Direction 3
- 4.7 Soldering Heat Shock
  - Temperature 260 ± 5 °c
  - Duration 2 ± 0.5 sec
- 4.8 Terminal Mechanical Strength
  - Strength 1kg
  - Duration 1 min

### Notice:

All specifications must be satisfied in this condition.  
Sensitivity :Allowable deviation within ±3dB from initial sensitivity.

This print and information here in are proprietary to Bestar Holding Co., Ltd. and shall not be used in whole or in part without its written content

				Date:	2014.10.07	BCM9750ULF-47-J50 LF
				Drawn by:	王焕焕	
A	2014.10.07	王焕焕		Checked by:	徐波	Microphone
Rev.	Date	Drawn	Note	Approved by:	徐金国	
BESTAR HOLDING CO.,LTD						DRG NO: BS/TEM01.450A
www.bestargroups.com wu@be-star.com						Page:5 of 7

# BCM9750ULF-47-J50 LF

## 5. Packing

100PCS  
per anti-static bag

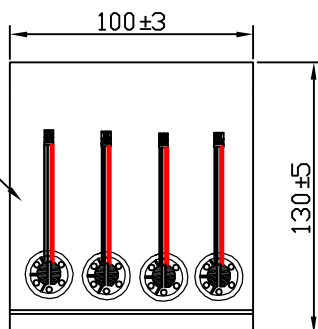

500 PCS  
5 anti-static bags per middle box

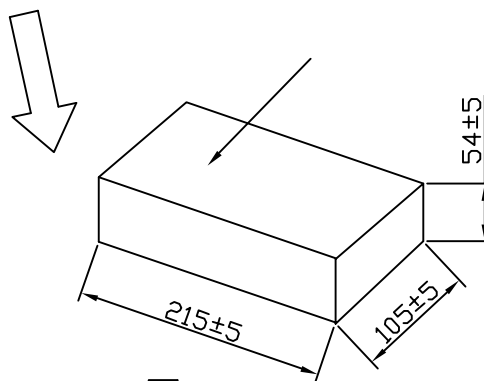

4500PCS  
9 middle boxes per carton

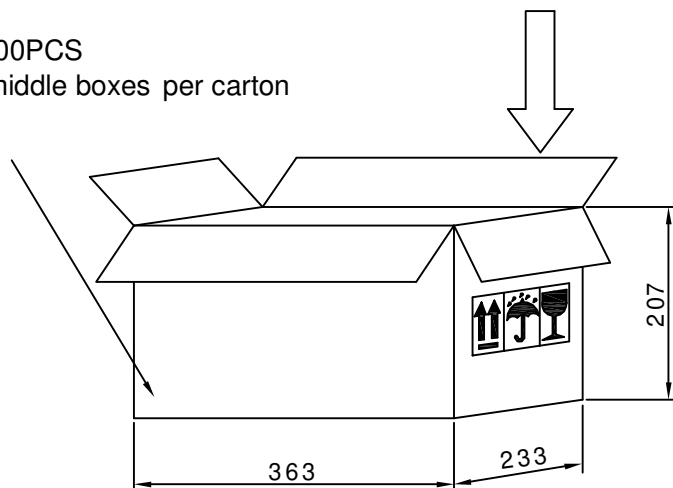

Remark:  
100 pcs per anti-static bag  
5 anti-static bags per middle box  
9 middle boxes per carton  
Total 4500pcs per carton  
Size: 363×233×207(mm)

This print and information there in are proprietary to Bestar Holding Co., Ltd. and shall not be used in whole or in part without its written consent.

				Date:	2014.10.07	BCM9750ULF-47-J50 LF
				Drawn by:	王焕焕	
A	2014.10.07	王焕焕		Checked by:	徐波	Microphone
Rev.	Date	Drawn	Note	Approved by:	徐金国	
BESTAR HOLDING CO.,LTD						DRG NO: BS/TEM01.450A
www.bestargroups.com _ wu@be-star.com						Page: 6 of 7

