

**Ten60 Power™
Receptacle
Removal Tool**

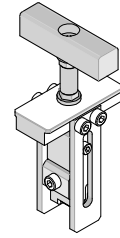

**Application Tooling
Specification Sheet**



Order No. 62100-7900

FEATURES

- Removes two terminals per tool cycle.
- Use tool 62100-7700 for removing the 5.5mm centerline receptacle housing.
- Use tool 62100-7750 for removing the 7.5mm centerline receptacle housing.

SCOPE

Products: Ten60Power™ Receptacle Assembly. See Product List below for specific order numbers.

Product List

The following is a partial list of the product order numbers and their specifications that this tool is designed to run. Updates to this list are available on www.molex.com.

Series No.	Assembly Order Number							
46532	46532-0001	46532-0002	46532-0003	46532-0004	46532-0005	46532-0006	46532-0007	46532-0008
	46532-0009	46532-0010	46532-0101	46532-0102	46532-0103	46532-0104	46532-0105	46532-0106
	46532-0107	46532-0108	46532-0109	46532-0110				
46562	46562-1000	46562-1001	46562-1002	46562-1003	46562-1004	46562-1005	46562-1006	46562-1007
	46562-1008	46562-1009	46562-1010	46562-1011	46562-1012	46562-1013	46562-1014	46562-1015
	46562-1016	46562-1017	46562-1018	46562-1019	46562-1020	46562-1021	46562-1022	46562-1023
	46562-1024	46562-1025	46562-1026	46562-1027	46562-1028	46562-1029	46562-1030	46562-1031
	46562-1032	46562-1033	46562-1034	46562-1035	46562-1036	46562-1037	46562-1038	46562-1039
	46562-1040	46562-1041	46562-1042	46562-1043	46562-1044	46562-1045	46562-1046	46562-1047
	46562-1048	46562-1049	46562-1050	46562-1051	46562-1052	46562-1053	46562-1054	46562-1055
	46562-1056	46562-1057	46562-1058	46562-1059	46562-1060	46562-1061	46562-1062	46562-1063
	46562-1064	46562-1065	46562-1066	46562-1067	46562-1068	46562-1069	46562-1070	46562-1071
	46562-1072	46562-1073	46562-1074	46562-1075	46562-1077	46562-1078	46562-1079	46562-1084
	46562-1085	46562-1086	46562-1087	46562-1088	46562-1090	46562-1093	46562-1094	46562-1097
	46562-1099	46562-1100	46562-1101	46562-1102	46562-1103	46562-1106	46562-1110	46562-1111
	46562-1112	46562-1116	46562-1117	46562-1119	46562-1123	46562-1124	46562-1125	46562-1126
	46562-1127	46562-1129	46562-1131	46562-1139	46562-1150	46562-1161	46562-1166	46562-1171
	46562-1172	46562-1190	46562-1191	46562-1194	46562-1195	46562-1197	46562-1199	46562-1206
	46562-1208	46562-1212	46562-1217	46562-1223	46562-1227	46562-1229	46562-1232	46562-1234
	46562-1235	46562-1239	46562-1240	46562-1246	46562-1260	46562-1264	46562-1270	46562-1271
	46562-1272	46562-1276	46562-1278	46562-1279	46562-1280	46562-1284	46562-1285	46562-1286
	46562-1290	46562-1295	46562-1297	46562-1300	46562-1302	46562-1303	46562-1305	46562-1307
	46562-1323	46562-1331	46562-1336	46562-1348	46562-1349	46562-1355	46562-1356	46562-1367
	46562-1375	46562-1379	46562-1383	46562-1388	46562-1389	46562-1390	46562-1394	46562-1401
	46562-1413	46562-1419	46562-1420	46562-1421	46562-1424	46562-1425	46562-1426	46562-1430
	46562-1445	46562-1446	46562-1447	46562-1463	46562-1469	46562-1470	46562-1475	46562-1493
	46562-1495	46562-1499	46562-1500	46562-1501	46562-1508	46562-1509	46562-1518	46562-1519
	46562-1524	46562-1527	46562-1528	46562-1529	46562-1530	46562-1532	46562-1537	46562-1542
	46562-1543	46562-1547	46562-1550	46562-1552	46562-1553	46562-1556	46562-1557	46562-1558

Series No.	Assembly Order Number							
46562	46562-1559	46562-1561	46562-1565	46562-1567	46562-1568	46562-1574	46562-1581	46562-1584
	46562-1589	46562-1590	46562-1591	46562-1594	46562-1602	46562-1603	46562-1610	46562-1611
	46562-1614	46562-1616	46562-1618	46562-1619	46562-1620	46562-1625	46562-1629	46562-1630
	46562-1632	46562-1636	46562-1637	46562-1645	46562-1646	46562-1650	46562-1652	46562-1653
	46562-1658	46562-1659	46562-1660	46562-1664	46562-1666	46562-1667	46562-1669	46562-1672
	46562-1674	46562-2001	46562-3001	46562-3002	46562-3003	46562-3004	46562-3005	46562-3006
	46562-3007	46562-3008	46562-3009	46562-3010	46562-3011	46562-3012	46562-3013	46562-3101
	46562-3102	46562-3103	46562-3104	46562-3105	46562-3106	46562-3107	46562-3108	46562-3109
	46562-3110	46562-3111	46562-3112	46562-3113	46562-3120	46562-3121	46562-3122	46562-3123
	46562-3124	46562-3125	46562-3126	46562-9001	46562-9002	46562-9003	46562-9004	46562-9005
	46562-9006	46562-9007	46562-9008	46562-9009	46562-9010	46562-9102	46562-9103	46562-9104
	46562-9105	46562-9106						

Tool Setup

The principal parts of the terminal removal tool are shown in Figure 1.

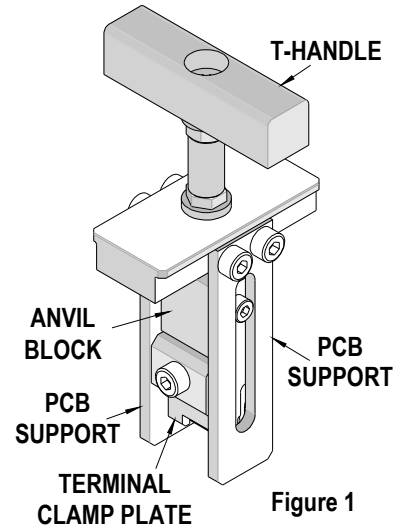

Figure 1

Tool Operation

1. Remove the receptacle housing using Molex tool 62100-7700 or 62100-7750. The terminals will be exposed as shown in Figure 2.
2. Turn the T-handle counterclockwise (CCW) until the clamp plates and anvil block are fully down. See Figure 1.

NOTE: The threaded shaft will disengage from the anvil block.

3. Using a 3mm hex wrench, loosen the two screws holding each clamp plate 1-1/2 turns.

NOTE: If the screws are not loosened, the tool will not fit over the power terminals.

4. Move the clamp plates away from the anvil.
5. Position the tool over a row of terminals.
6. Working from the top, move the anvil block and clamp plates down over the power terminals until the clamp plates rest on the shoulder of the terminal. See Figure 3.

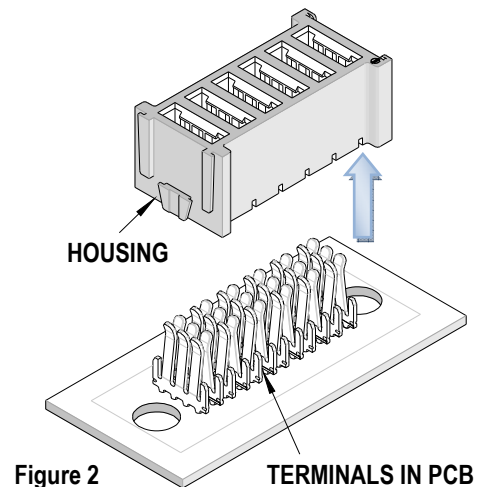
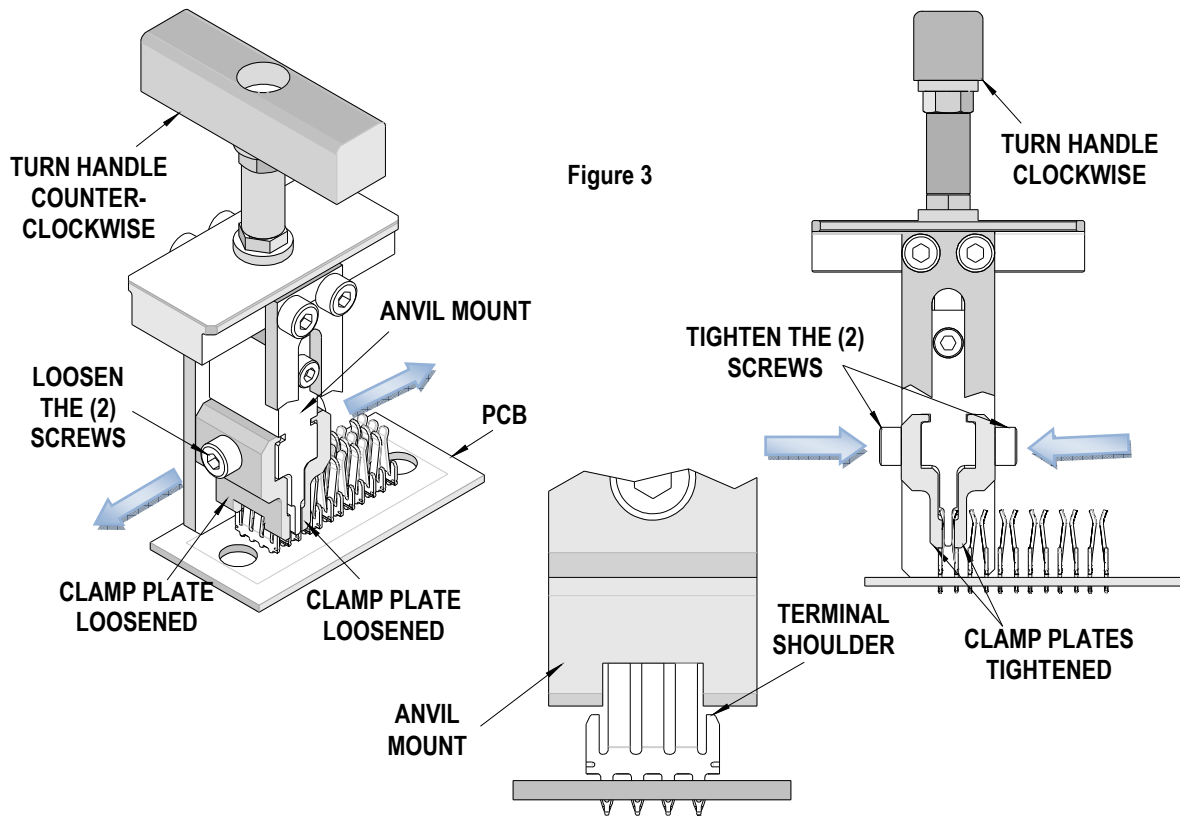

Figure 2



7. Tighten the screws holding the terminal clamp plates.
8. Turn the T-handle clockwise (CW) until the threaded shaft engages the anvil block.
9. Continue turning the T-handle; the PCB supports will contact the PCB then the terminals will be pulled up.
10. When the terminals are free from the PCB, pull the tool straight up and away from the PCB.
11. Loosen the clamp plate screws and take the terminals out of the tool.
12. After terminals are removed, they cannot be reused and should be discarded or recycled.

Contact Information

For more information on Molex application tooling please contact Molex at 1-800-786-6539.

Parts List

Item	Order No	Description	Quantity
	62100-7900	Ten60Power™ Receptacle Removal Tool	Figure 4
1	621007901	Anvil Block	1**
2	621007902	Side Plate Guide	2**
3	621007903	Terminal Clamp Plate	2**
4	621007904	Top Plate	1**
5	621006204	T Handle	1**
6	636001959	Collar	1**
7	636001960	Stop Screw	1**
8	637004553	E-Ring, 0.187" Shaft	1**
Hardware			
9	N/A	M3 by 5 Long SHCS	2**
10	N/A	M4 by 8 Long SHCS	6**
11	N/A	M5 Flat Washer	2**
12	N/A	M5 by 0.8 Jam Nut	1**

** Available from an industrial supply company such as MSC (1-800-645-7270).

Assembly Drawing

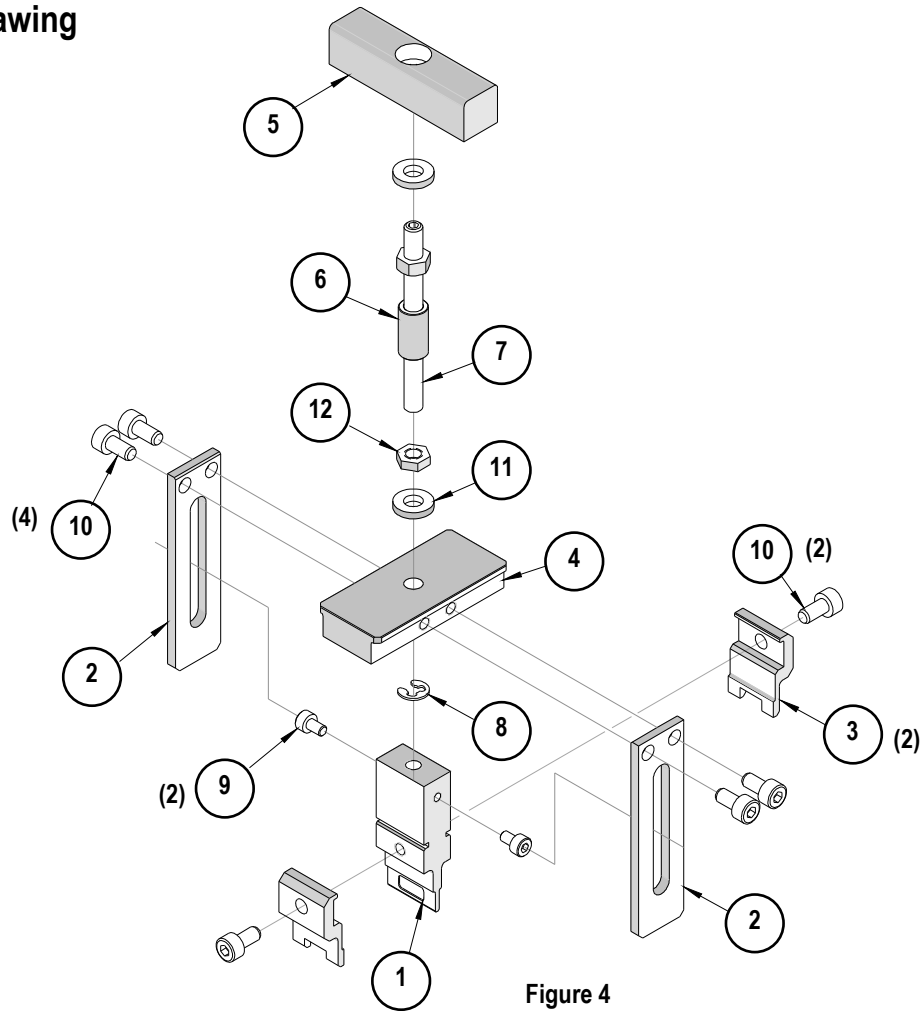

Figure 4

Visit our Web site at <http://www.molex.com>