

AN-1657 LM3401 Demo Board

1 Introduction

The Texas Instruments LM3401 is a switching buck regulator derived current source designed to drive a series string of high power, high brightness LEDs. The LM3401 controls an external P-FET, allowing the user to select a power device for the desired level of forward LED current. The LM3401 demo board can supply continuous current as high as 1.0A from an input voltage range of 4.5V to 35V. It is designed to operate at ambient temperatures up to 75°C.

The LM3401 maintains constant current through any number of series-connected LEDs as long as the input voltage is greater than the combined forward voltage of the LED string.

The LM3401 demo board includes an input terminal for a digital dimming signal, which is compatible with PWM dimming frequencies up to 10 kHz.

The complete demo board schematic is shown in [Figure 1](#). Typical waveforms and performance curves for the LM3401 demo board are shown in [Figure 3](#) through [Figure 10](#).

The standard Bill of Materials is shown in [Section 8](#), with an additional Bill of Materials for a high current application shown in [Table 3](#). The pcb layout is shown in [Figure 11](#) and [Figure 12](#).

2 Powering Up

First, referring to [Table 1](#), verify that the current setting resistor, R1, matches the desired LED current, and that the current limit resistor (R3) is set appropriately. The default values for R1 and R3 set the average LED current at 340 mA with a typical peak current limit threshold of 1.5A.

Next, connect the LED string to the terminals as shown in [Figure 2](#). Connect the input voltage supply to the VIN and GND terminal posts. If dimming is being used, connect a digital PWM signal to the DIM post. When all connections and polarities are verified, power can be applied. LED strings should not be connected or disconnected from the output terminals while the demo board is powered up.

The LM3401 demo board can be easily modified to drive a variety of LEDs. Three current setting options are described in [Table 1](#). For more detailed design and device information, refer to *LM3401 Hysteretic PFET Controller for High Power LED Drive* ([SNVS516](#)).

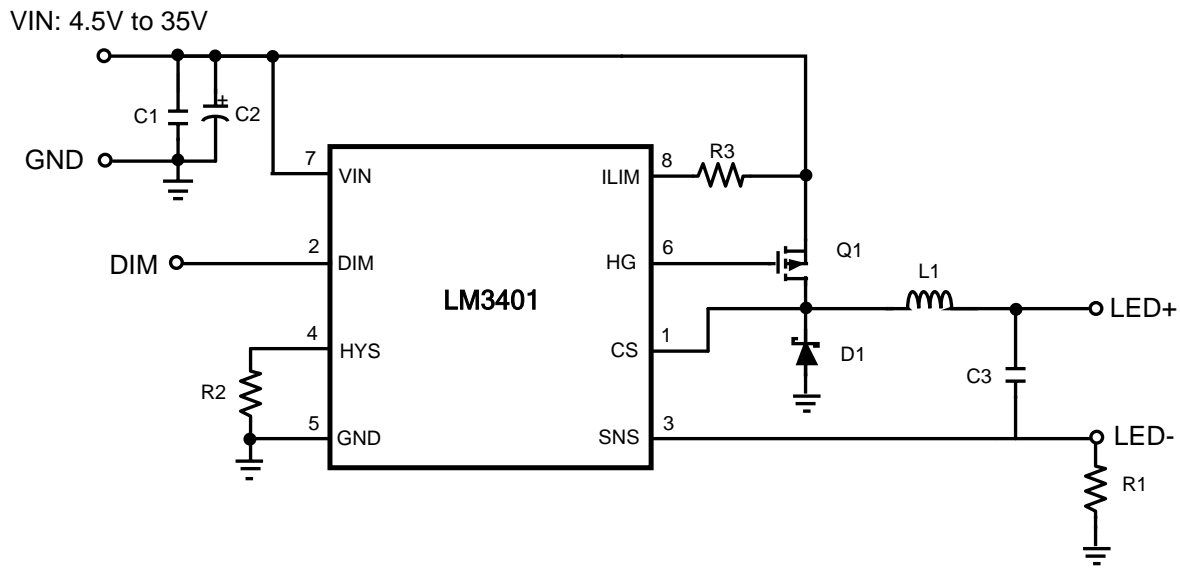
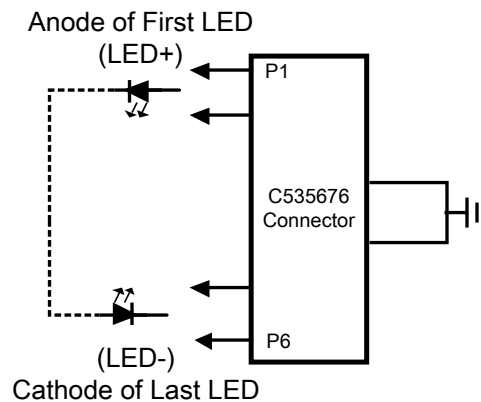

Figure 1. Complete LM3401 Demo Board Schematic
Table 1. LED Current Setting Resistors

LED average current	R1	R3 (typical current limit)	R1 power dissipation
340 mA ⁽¹⁾	0.59Ω ⁽¹⁾	24.9 kΩ (1.5A) ⁽¹⁾	68 mW
700 mA	0.29Ω	47 kΩ (2.8A)	142 mW
1.0A	0.20Ω	68 kΩ (3.9A)	200 mW

⁽¹⁾ Default value

3 Connecting the LED Array

The LM3401 demo board includes a female 6-pin SIP connector as well as two turret posts for the cathode and anode connections of the LED array. These are labeled “LED+” and “LED-“. Either connection can be used. [Figure 2](#) shows the pinout of the SIP connector.

Figure 2. LED Connection

4 Ripple Reduction Capacitor C3

The component C3 is optional and not installed on the standard demo board. This capacitor is used to reduce LED ripple current without changing average LED current or inductor current. Without C3, the LED ripple current is equal to the inductor ripple current. The peak-to-peak ripple current values shown in [Table 2](#) are without C3 installed. A typical C3 value of 1 μF is recommended for most applications. Any type of low ESR capacitor can be used. However, the working voltage must be rated higher than the maximum input voltage. C3 can also be used to reduce switching noise which could affect the SNS and DIM pins, especially at higher LED current. For noise reduction purposes, a C3 value of 220 pF is recommended.

Table 2. Typical Operating Conditions

# of Series LEDs	LED Type	Average LED Current	Freq. ⁽¹⁾	p-p Ripple ⁽¹⁾	Minimum VIN
1	Osram golden dragon	340 mA	425 kHz	110 mA	4.5V
2	Osram golden dragon	340 mA	655 kHz	110 mA	7.0V
3	Luxeon Star	340 mA	800 kHz	110 mA	10.4V
4	Luxeon Star	340 mA	845 kHz	110 mA	13.8V
1	Luxeon V Star	700 mA	415 kHz	190 mA	7.0V
2	Luxeon V Star	700 mA	500 kHz	190 mA	14.5V
1	Luxeon K2 Emitter	1A	230 kHz	280 mA	4.5V

⁽¹⁾ at 24Vin

5 PWM Dimming

The DIM terminal on the PCB provides an input for a pulse width modulated (PWM) signal to control dimming of the LED string. The PWM signal should have a minimum logic high level of 2.25V, and minimum low and high periods of 100 ns. For the default demo board circuit, a dimming frequency less than 1kHz is recommended to maintain an adequate contrast ratio. The maximum contrast ratio is shown in [Figure 10](#), and assumes a minimum of 2 switching cycles. The maximum contrast ratio depends largely on the rise time of the inductor current, and therefore is dependant on input voltage, inductor size, and LED string forward voltage. Additionally, if C3 is installed, the maximum contrast ratio or DIM frequency will be further reduced.

6 Open Circuit/Short Circuit

If the LED array is disconnected or fails open, the LM3401 will operate at 100% duty cycle. The output voltage (at LED+) and CS node will rise to equal the input voltage; the circuit is rated to 40V and will not suffer damage. However, care should be taken not to connect an LED string when the demo board is powered up and the output is high as excessive surge current may damage the LEDs.

The default current limit threshold is typically 1.5A, set by R3. The current limit will protect the circuit from a short at the LED anode or cathode. Current limit is sensed across the R_{DSon} of the PFET and will therefore vary with temperature. R3 can be adjusted if a different current limit threshold is required. For the current limit details, refer to [LM3401 Hysteretic PFET Controller for High Power LED Drive \(SNVS516\)](#).

7 LED String Options

The default LED current setting is 340 mA, typical of many 1W LEDs. To adjust this value, the current setting resistor, R1, can be changed according to [Table 1](#). For other values, use the equation below:

$$R1 = \frac{200 \text{ mV}}{I_{LED}} \quad (1)$$

R1 must be rated to handle the power dissipation of the LED current. For example, in steady state R1 will dissipate $(0.340^2 \times 0.59) = 68 \text{ mW}$, indicating that a resistor with a 1/8W power rating would be appropriate.

The LM3401 demo board can drive a wide variety of LEDs. Ripple current and switching frequency will vary with the LED forward voltage, number of LEDs, and input voltage. [Table 2](#) shows the typical results for some common LED strings when using the [Table 1](#) settings at an input voltage of 24V. Typical switching frequency vs input voltage is shown in [Figure 5](#).

For some LED strings, the demo board settings given in [Table 1](#) may not be appropriate. For example, where the switching frequency increases above the 1.5 MHz maximum or where LED ripple current is higher than the maximum LED rating. In this case, refer to *LM3401 Hysteretic PFET Controller for High Power LED Drive* ([SNVS516](#)) to modify the demo board as needed.

The LM3401 can also drive LED currents in excess of 1A. For these applications a larger pad is provided for a higher current PFET. An example BOM for a typical 3.5A application is shown in [Table 3](#). The switching frequency, ripple current, and current limit values will depend on the number and type of LEDs installed, as well as the selected PFET. A low Vgs threshold PFET is recommended for higher current applications, as the initial HG voltage will decrease somewhat when driving PFETs with a larger gate capacitance. For detailed design information, refer to *LM3401 Hysteretic PFET Controller for High Power LED Drive* ([SNVS516](#)).

Table 3. Bill of Materials for 3.5A Application (Vin = 5V to 20V)

Ref. #	Description	Part Number	Size	Vendor
IC1	LED Controller	LM3401	VSSOP-8	Texas Instruments
L1	5.2 μH, 5A, Inductor	MSS1038-522NL	10.2 × 10.4	Coilcraft
Q1	20V, 4A, 25 mΩ, PFET	Si3493BDV	SO-6	Vishay
D1	30V, 4A, Schottky	SSB43L	SMB	Vishay
C1	25V, 10 μF, ceramic	C3225X5R1E106K	1210	TDK
C2	50V, 33 μF, electrolytic	EEEHA1H330XP	6.6 × 6.6	Panasonic
C3	25V, 220 pF, ceramic	-	0805	-
R1	0.0576Ω, 1%, 1W	WSL2512R0576F	2512	Vishay
R2	4.7 kΩ, 1%	-	0805	-
R3	40 kΩ, 1%	-	0805	-

8 Bill of Materials

Table 4. Bill of Materials

Ref. #	Description	Part Number	Size	Vendor
IC1	LED Controller	LM3401	VSSOP-8	Texas Instruments
L1	68 μ H, 1.7A, Inductor	MSS1260T-683ML	12 \times 12	Coilcraft
Q1	40V, 1.8A, 100 m Ω , PFET	Si2319DS	SOT-23	Vishay
D1	40V, 2A, Schottky	SSA24	SMA	Vishay
C1	50V, 2.2 μ F, ceramic	C3225X5R1H225K	1210	TDK
C2	50V, 33 μ F, electrolytic	EEEHA1H330XP	6.6 \times 6.6	Panasonic
C3*	Not installed	-	1206	-
R1	0.59 Ω , 1%, 1/4W	SR732BLTER590F	1206	KOA
R2	5.76 k Ω , 1%	CRCW08055761F	0805	Vishay
R3	24.9 k Ω 1%	CRCW08052492F	0805	Vishay

9 Typical Performance Characteristics

Unless otherwise specified, the following conditions apply: $V_{in} = 24V$, $T_a = 25^\circ C$, LED = 2 \times Osram Golden Dragon ($V_f = 3.4V$, $I_f = 350 mA$)

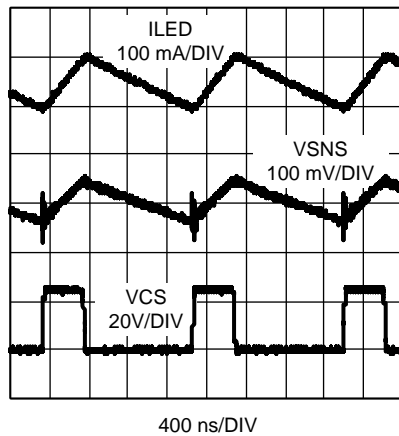
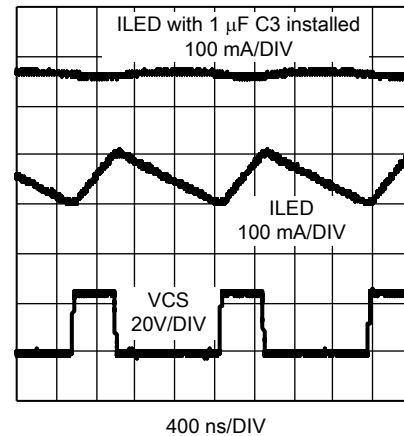
Figure 3. CS, SNS, and LED Current Waveforms

Figure 4. ILED with and without C3

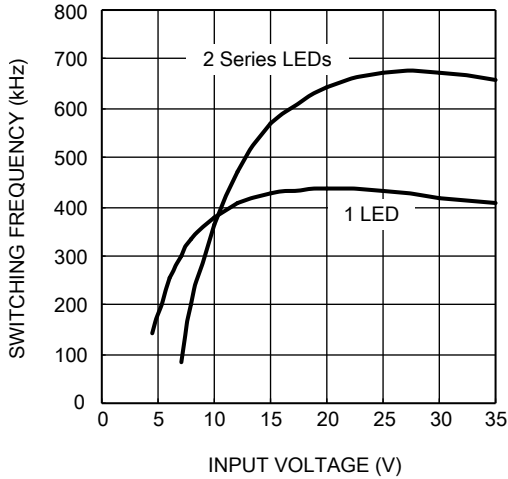

Figure 5. Switching Frequency vs VIN

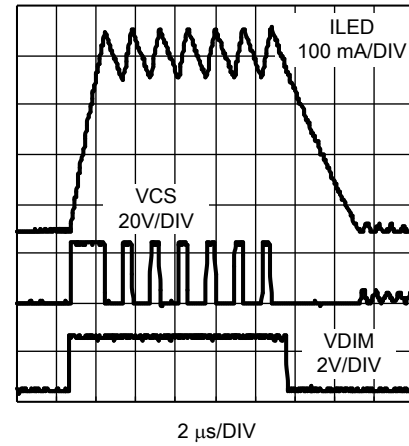

Figure 6. Dimming Waveforms

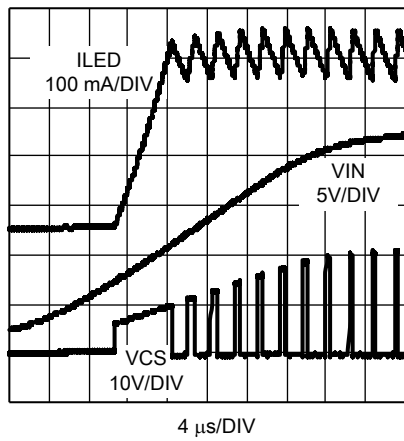

Figure 7. Startup Waveforms

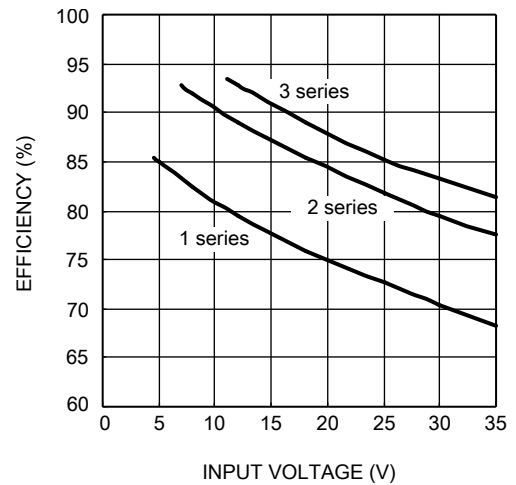

Figure 8. Efficiency vs Input Voltage Driving 350 mA LEDs

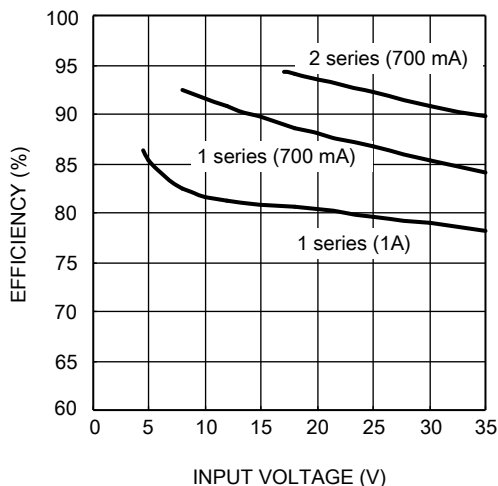

Figure 9. Efficiency vs Input Voltage Driving 700 mA and 1A LEDs

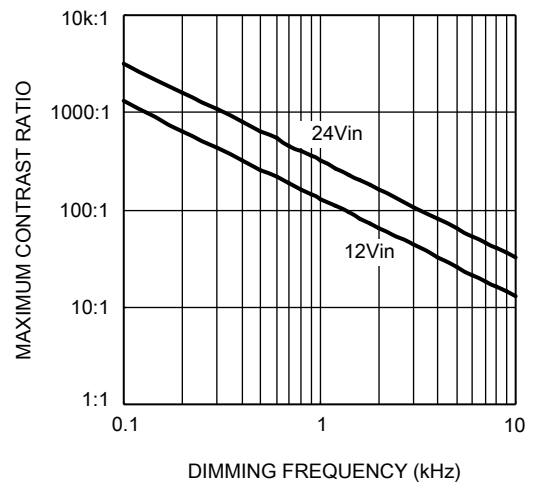

Figure 10. Maximum Contrast Ratio vs Dimming Frequency (100:1 = 1% duty)

10 PCB Layout

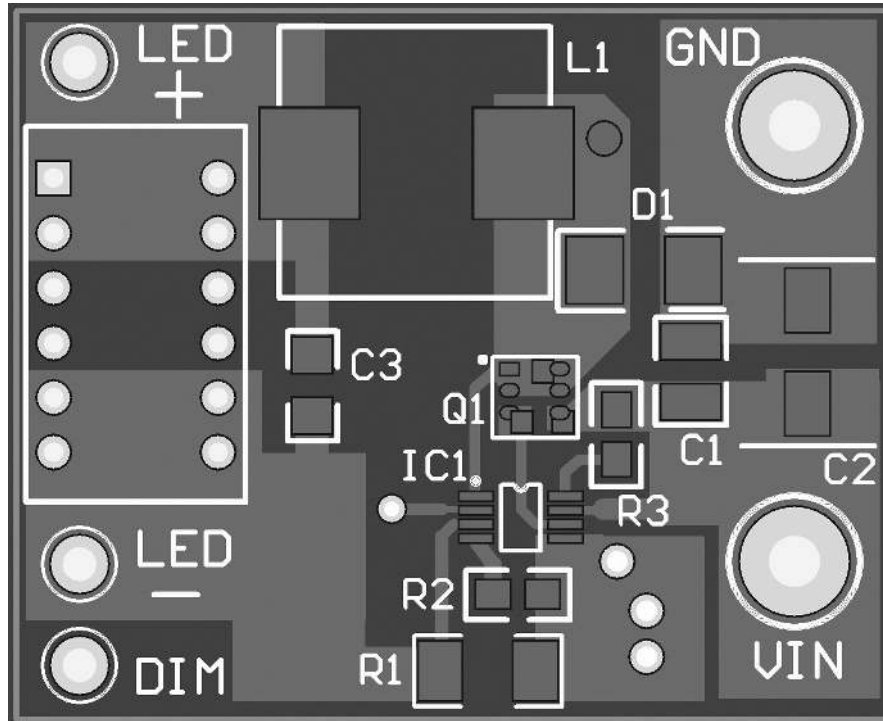

Figure 11. Top Side PCB Layout

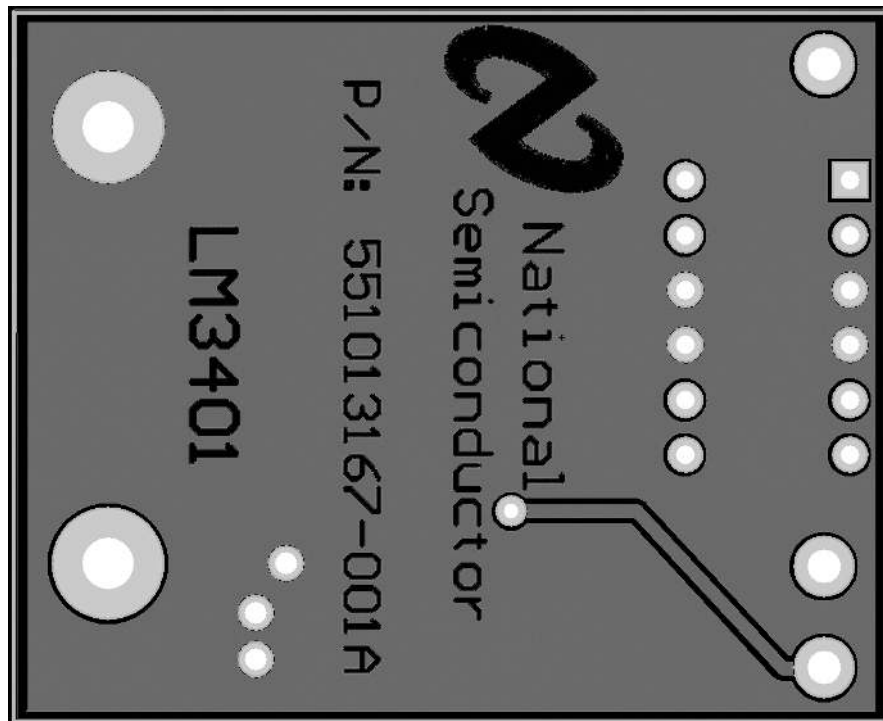

Figure 12. Bottom Side PCB Layout

IMPORTANT NOTICE

Texas Instruments Incorporated and its subsidiaries (TI) reserve the right to make corrections, enhancements, improvements and other changes to its semiconductor products and services per JESD46, latest issue, and to discontinue any product or service per JESD48, latest issue. Buyers should obtain the latest relevant information before placing orders and should verify that such information is current and complete. All semiconductor products (also referred to herein as "components") are sold subject to TI's terms and conditions of sale supplied at the time of order acknowledgment.

TI warrants performance of its components to the specifications applicable at the time of sale, in accordance with the warranty in TI's terms and conditions of sale of semiconductor products. Testing and other quality control techniques are used to the extent TI deems necessary to support this warranty. Except where mandated by applicable law, testing of all parameters of each component is not necessarily performed.

TI assumes no liability for applications assistance or the design of Buyers' products. Buyers are responsible for their products and applications using TI components. To minimize the risks associated with Buyers' products and applications, Buyers should provide adequate design and operating safeguards.

TI does not warrant or represent that any license, either express or implied, is granted under any patent right, copyright, mask work right, or other intellectual property right relating to any combination, machine, or process in which TI components or services are used. Information published by TI regarding third-party products or services does not constitute a license to use such products or services or a warranty or endorsement thereof. Use of such information may require a license from a third party under the patents or other intellectual property of the third party, or a license from TI under the patents or other intellectual property of TI.

Reproduction of significant portions of TI information in TI data books or data sheets is permissible only if reproduction is without alteration and is accompanied by all associated warranties, conditions, limitations, and notices. TI is not responsible or liable for such altered documentation. Information of third parties may be subject to additional restrictions.

Resale of TI components or services with statements different from or beyond the parameters stated by TI for that component or service voids all express and any implied warranties for the associated TI component or service and is an unfair and deceptive business practice. TI is not responsible or liable for any such statements.

Buyer acknowledges and agrees that it is solely responsible for compliance with all legal, regulatory and safety-related requirements concerning its products, and any use of TI components in its applications, notwithstanding any applications-related information or support that may be provided by TI. Buyer represents and agrees that it has all the necessary expertise to create and implement safeguards which anticipate dangerous consequences of failures, monitor failures and their consequences, lessen the likelihood of failures that might cause harm and take appropriate remedial actions. Buyer will fully indemnify TI and its representatives against any damages arising out of the use of any TI components in safety-critical applications.

In some cases, TI components may be promoted specifically to facilitate safety-related applications. With such components, TI's goal is to help enable customers to design and create their own end-product solutions that meet applicable functional safety standards and requirements. Nonetheless, such components are subject to these terms.

No TI components are authorized for use in FDA Class III (or similar life-critical medical equipment) unless authorized officers of the parties have executed a special agreement specifically governing such use.

Only those TI components which TI has specifically designated as military grade or "enhanced plastic" are designed and intended for use in military/aerospace applications or environments. Buyer acknowledges and agrees that any military or aerospace use of TI components which have **not** been so designated is solely at the Buyer's risk, and that Buyer is solely responsible for compliance with all legal and regulatory requirements in connection with such use.

TI has specifically designated certain components as meeting ISO/TS16949 requirements, mainly for automotive use. In any case of use of non-designated products, TI will not be responsible for any failure to meet ISO/TS16949.

Products

Audio	www.ti.com/audio
Amplifiers	amplifier.ti.com
Data Converters	dataconverter.ti.com
DLP® Products	www.dlp.com
DSP	dsp.ti.com
Clocks and Timers	www.ti.com/clocks
Interface	interface.ti.com
Logic	logic.ti.com
Power Mgmt	power.ti.com
Microcontrollers	microcontroller.ti.com
RFID	www.ti-rfid.com
OMAP Applications Processors	www.ti.com/omap
Wireless Connectivity	www.ti.com/wirelessconnectivity

Applications

Automotive and Transportation	www.ti.com/automotive
Communications and Telecom	www.ti.com/communications
Computers and Peripherals	www.ti.com/computers
Consumer Electronics	www.ti.com/consumer-apps
Energy and Lighting	www.ti.com/energy
Industrial	www.ti.com/industrial
Medical	www.ti.com/medical
Security	www.ti.com/security
Space, Avionics and Defense	www.ti.com/space-avionics-defense
Video and Imaging	www.ti.com/video

TI E2E Community

e2e.ti.com