

REV.	DATE	ECR NO.	DESCRIPTION
NC	08/06/10	XXXXXX	INITIAL RELEASE
A	09/09/10	2096	CHANGE GASKET TO A ROUN O-RING

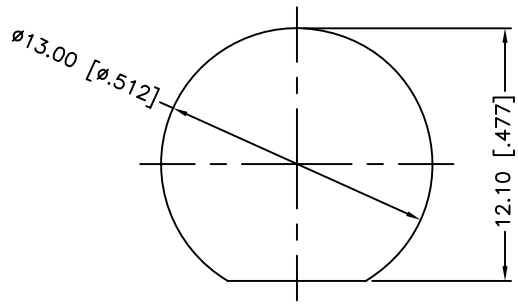

RECOMMENDED MOUNTING HOLE

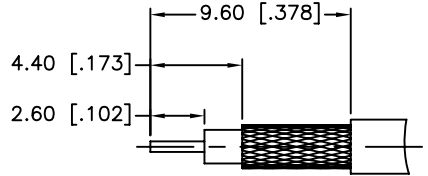

RECOMMENDED CABLE STRIPPING DIM'S

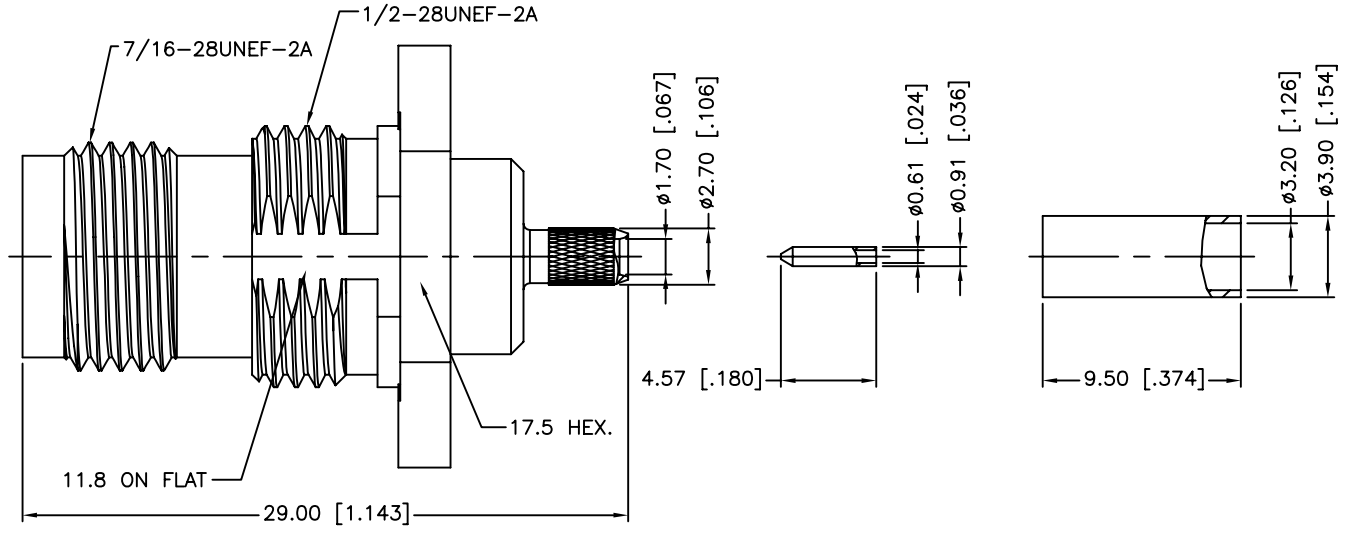
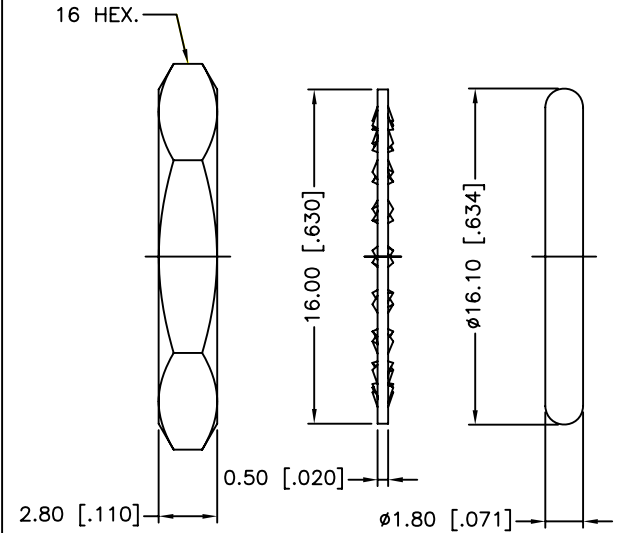

1. CRIMPED FERRULE
HEX CRIMP SIZE .128"
2. CRIMPED CONTACT PIN
SQ. CRIMP SIZE 0.7 MM
3. SEALED TO IP67.

QTY	DESCRIPTION	MATERIAL	FINISH
1	HEX NUT	BRASS	NICKEL
1	LOCK WASHER	BRASS	NICKEL
1	GASKET	SILICONE	RED
1	FERRULE	BRASS	NICKEL
1	CONTACT PIN	BRASS	GOLD
1	RETAINING RING	BRASS	NICKEL
1	CONTACT PIN	PHOSPHOR BRONZE	GOLD
1	GASKET	SILICONE	RED
1	INSULATOR	PTFE	NATURAL
1	BODY	BRASS	NICKEL

UNLESS OTHERWISE SPECIFIED DIMENSIONS ARE IN MILLIMETERS. DIMENSIONS IN [] ARE IN INCHES AND FOR CUSTOMER REFERENCE ONLY.

UNLESS OTHERWISE SPECIFIED TOLERANCES FOR MILLIMETERS ARE:
0.5 - 8mm ± 0.20mm
8 - 30mm ± 0.40mm
30 - 120mm ± 0.50mm

UNLESS OTHERWISE SPECIFIED TOLERANCES FOR INCHES ARE:
.020 - .315 = ± 0.007"
.315 - 1.180 = ± 0.015"
1.180 - 4.724 = ± 0.020"

DO NOT SCALE DRAWING

APPROVALS	DATE
DRAWN M.ZHANG	09/09/10
CHECKED	
ISSUED	
SHEET 1 OF 1	
CAD FILE C:/CONNEX/122192-15RP.DWG	

Amphenol Connex

RP-TNC BULKHEAD CRIMP JACK, IP-67 COMPLIANT (FOR RG-174 AND 316U CABLE)

PART NO. **122192-15RP**

DWG. NO. 122192-15RP.DWG REV. A SIZE A SCALE NA