

ITEM NO.	NAME	MATERIAL	NOTES
1	HOUSING	PA66	UL94-V0
2	WIRE SCREW	STEEL	M8/ZN PLATED
3	WIRE CONNECTOR	STEEL	M8/ZN PLATED
4	CONDUCTOR	COPPER ALLOY	TIN PLATED
5	MOUNT SCREW	STEEL	M6/ZN PLATED
6	GROUND CLMAP	COPPER ALLOY	TIN PLATED

PART NO.	COLOR	PANTONE #
DG230-YG	YELLOW/GREEN	7404U/362U

REVISIONS					
REV	ZONE	DESCRIPTION	DATE	ECN	BY
A	-	INITIAL RELEASE	09/24/2012	BU-J12374	TJN

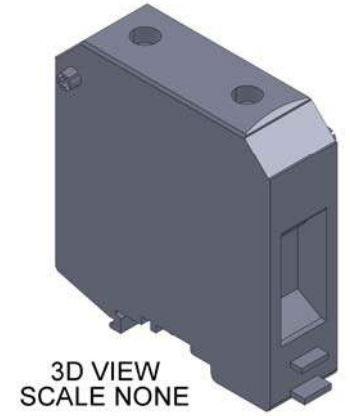
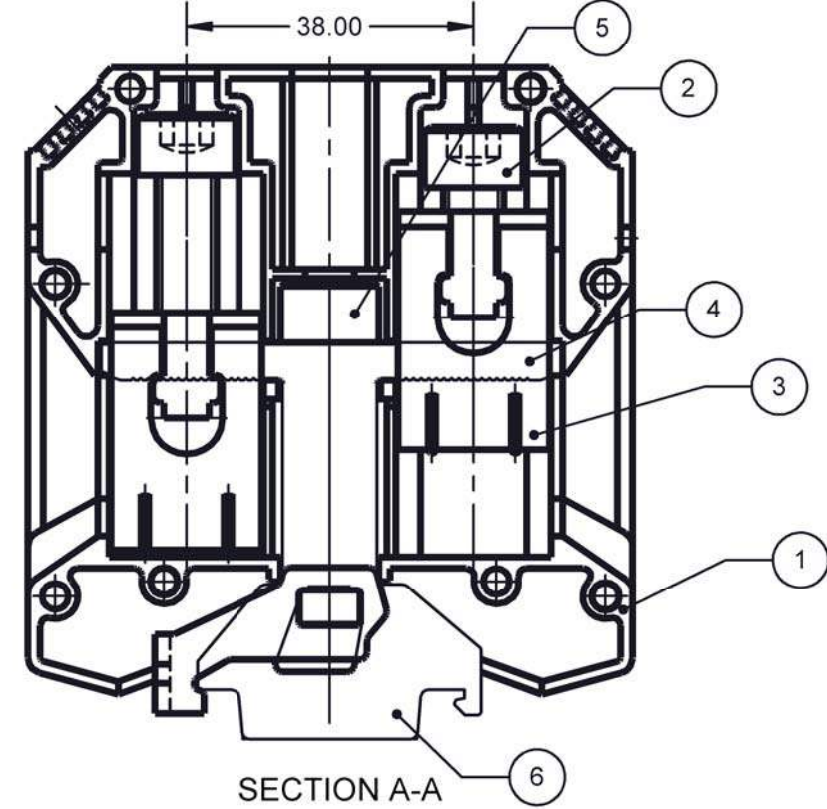
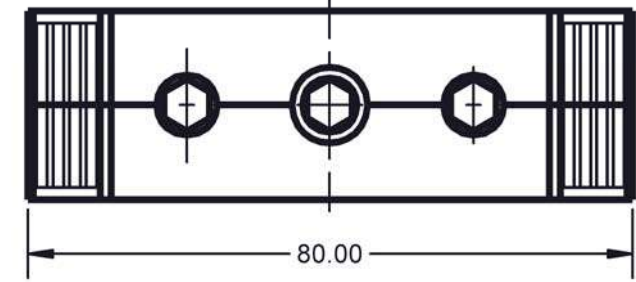
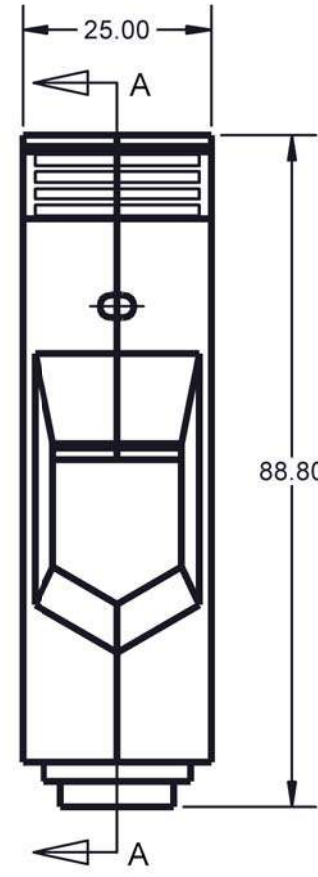
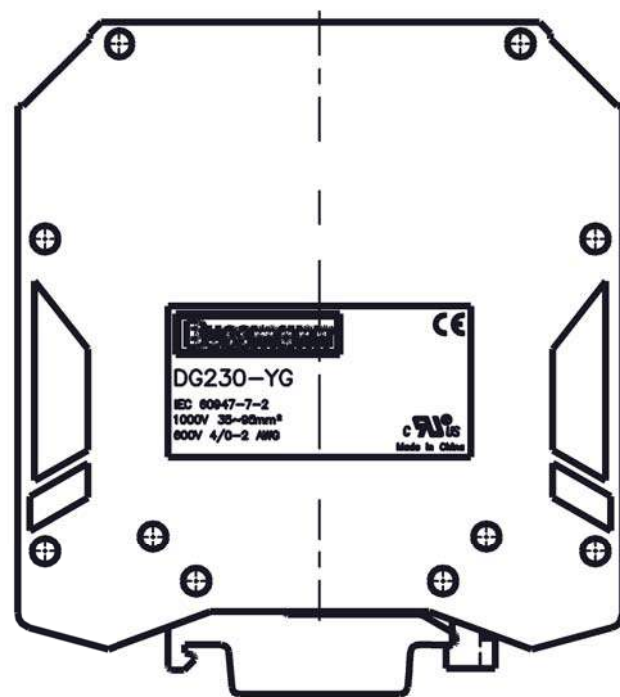

- NOTES:
- RATINGS: UL 600V, IEC 1000V
INSULATION WITHSTAND VOLTAGE 750VAC/1MINUTE
TEMPERATURE RANGE -40°C~105°C
 - SEE 2A2943 FOR DIN DIMENSION DETAILS
 - WIRE SCREW TORQUE 11.6N-M (100.6IN-LB)
 - CLAMPING SCREW TORQUE 5.7N-M (49.4IN-LB)
 - WIRE RANGE UL 2~4/0AWG, IEC 35~95 mm²
 - ASSEMBLY MUST BE FREE OF OIL, GREASE AND OTHER FOREIGN MATERIALS.
 - ASSEMBLY MUST COMPLY WITH RoHS SPECIFICATION #1P2163.

MODEL SOURCE DATA	MODEL VERSION	GENERAL DRAWING PRACTICES IN ACCORDANCE WITH ASME - Y14.100-2004 DIMENSIONS AND TOLERANCES IN ACCORDANCE WITH ASME - Y14.5M-1994	APPROVALS	DATE	 St. Louis, MO 63178 (USA)
THIS DRAWING IS AN UNCONTROLLED COPY IF PRINTED OR SENT ELECTRONICALLY. DO NOT SCALE DRAWING		UNLESS OTHERWISE SPECIFIED DIMENSIONS ARE IN MILLIMETERS TOLERANCES TO BE ONE PLACE X.X = ±0.3 mm TWO PLACE X.X X = ±0.13 mm ALL ANGLES X X = ±1°	ENGINEER TJN	09/26/2012	
CONFIDENTIAL. THE INFORMATION CONTAINED IN THIS DOCUMENT IS THE PROPERTY OF COOPER INDUSTRIES, INC. IT IS NOT FOR PUBLIC DISCLOSURE. POSSESSION OF THE INFORMATION DOES NOT CONVEY ANY RIGHT TO LOAN, SELL, OR DISCLOSE THE INFORMATION. UNAUTHORIZED REPRODUCTION OR USE OF THE INFORMATION IS PROHIBITED. THIS DOCUMENT IS TO BE RETURNED TO COOPER INDUSTRIES, INC. UPON COMPLETION OF THE PURPOSE FOR WHICH IT WAS LOANED OR UPON REQUEST.		SPECIAL CHARACTERISTIC $\diamond (0)$ SIGNIFICANT CHARACTERISTIC $\triangle (0)$	MANUFACTURING ENGINEER ---	--/--/----	TITLE GROUNDING TERMINAL BLOCK
COPYRIGHT © COOPER INDUSTRIES, INC. THIS IS AN UNPUBLISHED WORK. THE DISCLOSURE OF THIS WORK IS LIMITED TO SELECT PERSONNEL. FURTHER DISSEMINATION OR DISCLOSURE TO THE PUBLIC IS PROHIBITED. THIS UNPUBLISHED WORK IS PROTECTED BY FEDERAL COPYRIGHT LAW AND ALL RIGHTS THEREUNDER ARE RESERVED BY COOPER INDUSTRIES, INC.		THIRD ANGLE PROJECTION	MATERIAL SEE TABLE	REV SEE TABLE	SIZE A3
			SCALE: 1:1		DWG NO. DG230-YG
			SHEET 1 OF 1		REV A