

REVISIONS				
P	LTR	DESCRIPTION	DATE	APP'D
B4	REVISED PER	ECO-17-002273	10OCT2017	RK AS

SPECIFICATIONS:

**MATERIALS:**  
CASE: NYLON 66, BLACK  
ACTUATOR: NYLON 66 OR PPS, SEE P/N TABLE  
COVER: STEEL, TIN FINISH  
MOVING CONTACT: COPPER ALLOY-SILVER FINISH  
FIXED CONTACT/TERMINAL: COPPER ALLOY-SILVER OVER NICKEL FINISH

**ELECTRICAL:**  
MAX CONTACT RATING: 50MILLIAMPS@24V DC,  
MIN CONTACT RATING: 10MICROAMPS@1V DC  
INITIAL CONTACT RESISTANCE, 100 MILLIOHMS MAX  
INSULATION RESISTANCE, 100 MEGOHM MIN. @ 100V DC  
DIELECTRIC STRENGTH, 500 V AC FOR 1 MINUTE  
LIFE EXPECTANCY, 100,000 CYCLES MIN (2 CYCLES PER SECOND AND 150% ACTUATION FORCE), EXCEPT FOR THE 520 GF MODEL WHICH WOULD BE 50,000 CYCLES MIN.

**MECHANICAL:**  
ACTUATION FORCE, SEE TABLE  
ACTUATION TRAVEL, .010 +.008/-.004  
LIFE EXPECTANCY, 100,000 CYCLES MIN (2 CYCLES PER SECOND AND 150% ACTUATION FORCE), EXCEPT FOR THE 520 GF MODEL WHICH WOULD BE 50,000 CYCLES MIN.

**ENVIRONMENTAL:**  
OPERATING TEMPERATURE, -35 TO +85 DEGREES C  
STORAGE TEMPERATURE, -35 TO +85 DEGREES C  
THERMAL SHOCK, PER EIA-364-32C, -35 TO +85 DEGREES C  
SOLDERABILITY, PER EIA-364-52, CLASS 2, CATEGORY 1, CATEGORY 2, 95% MINIMUM COVERAGE  
RESISTANCE TO SOLDER HEAT, PER 109-202, CONDITION B

**Notes:**  
1. ALL MATERIALS AND FINISHES SHALL COMPLY WITH EU DIRECTIVE 2002/95/EC OF 27JAN2003 (ROHS).

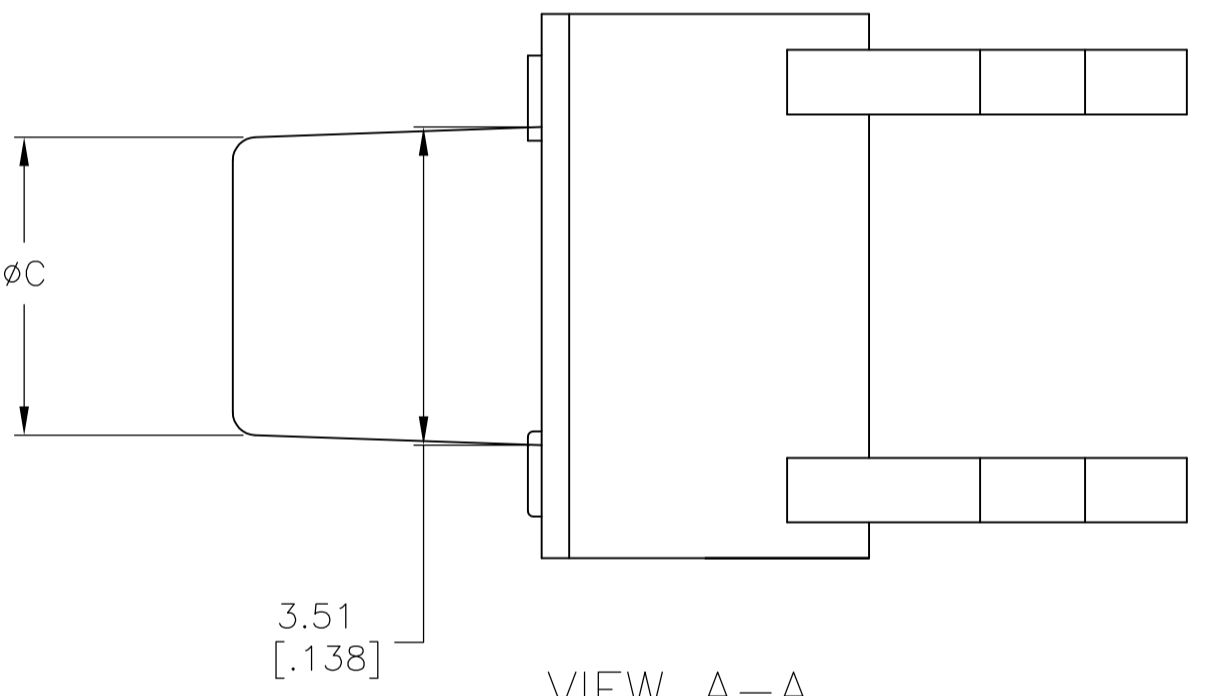
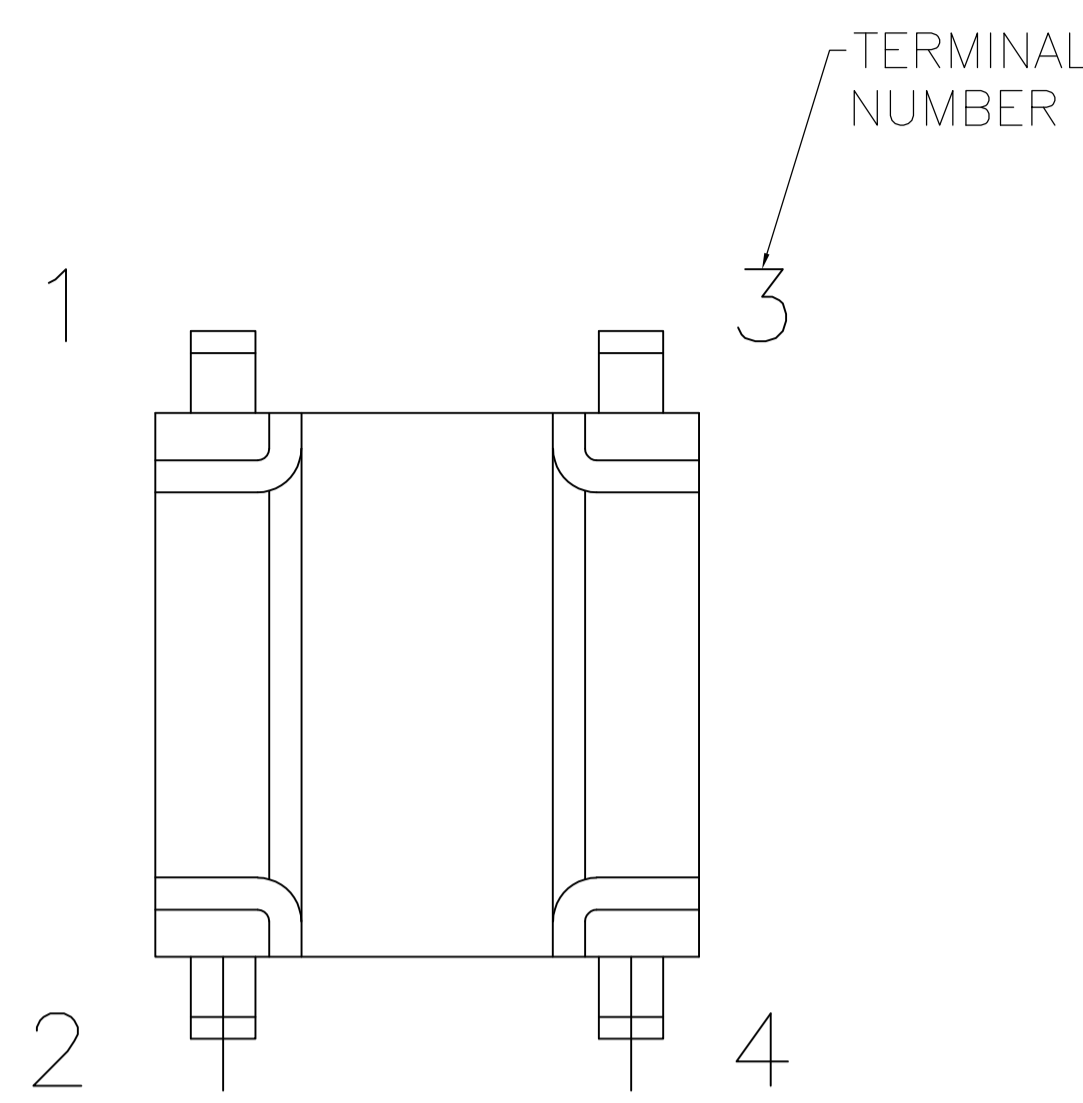
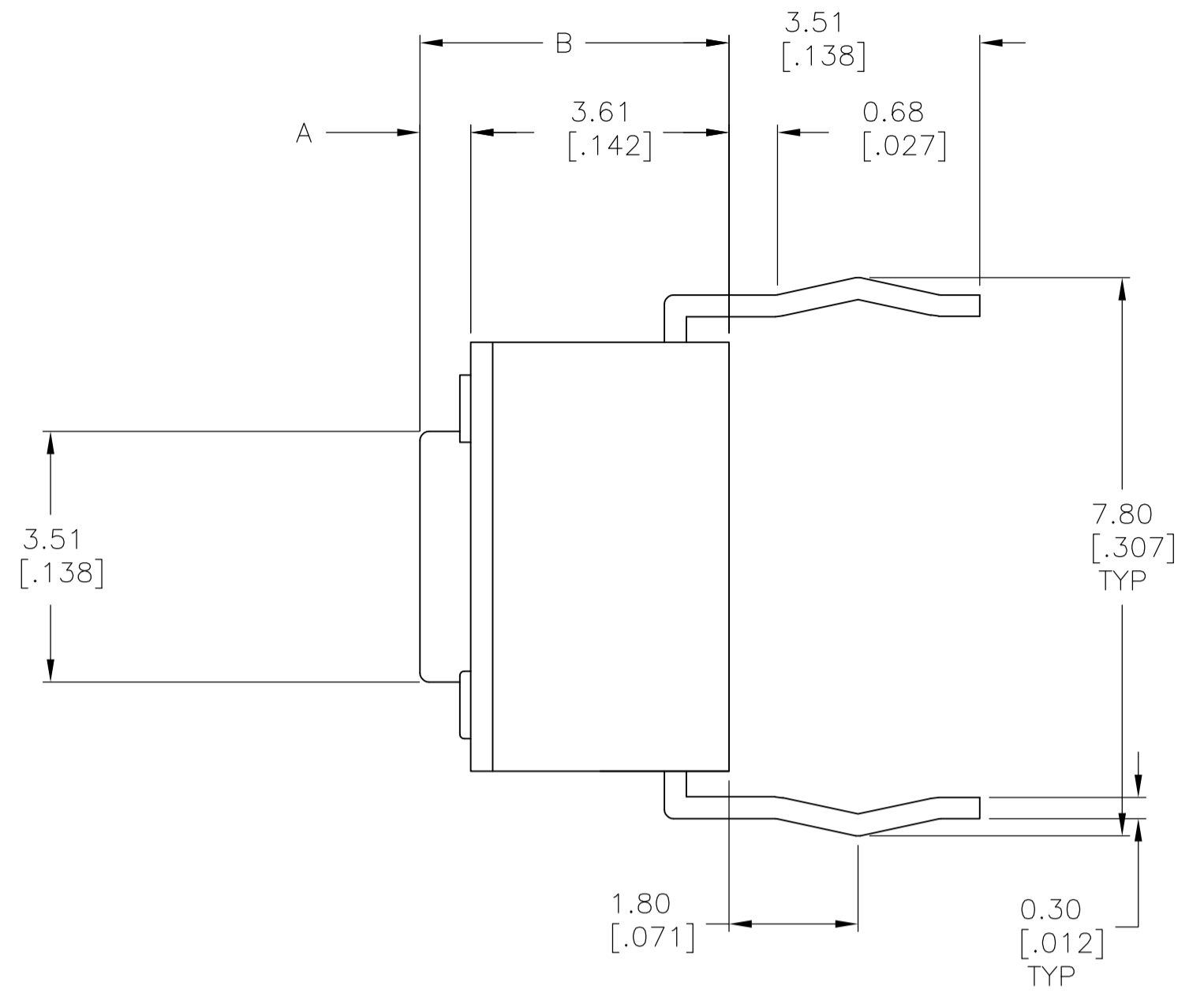
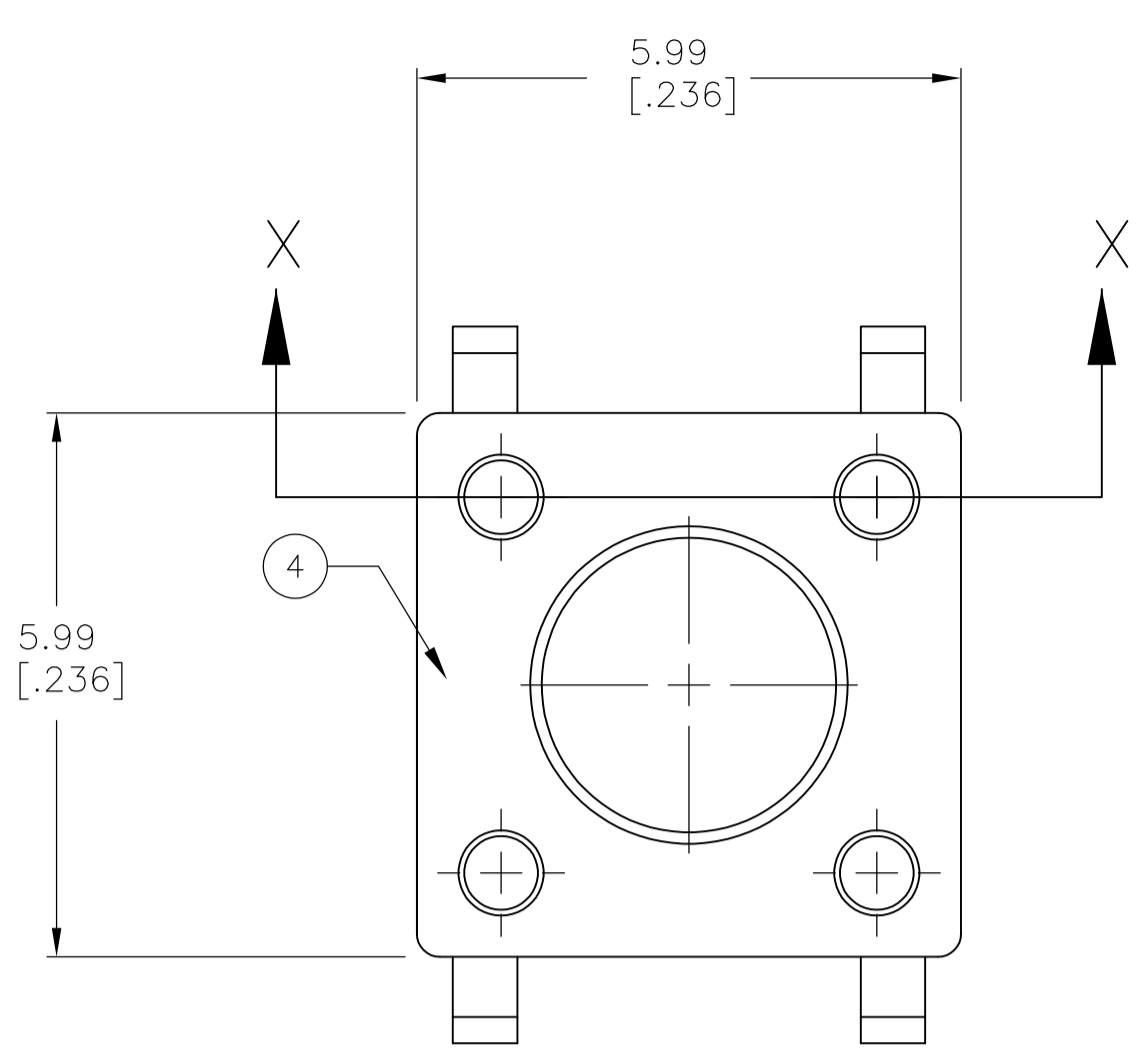

VIEW A-A  
FSM6J THRU FSM18J

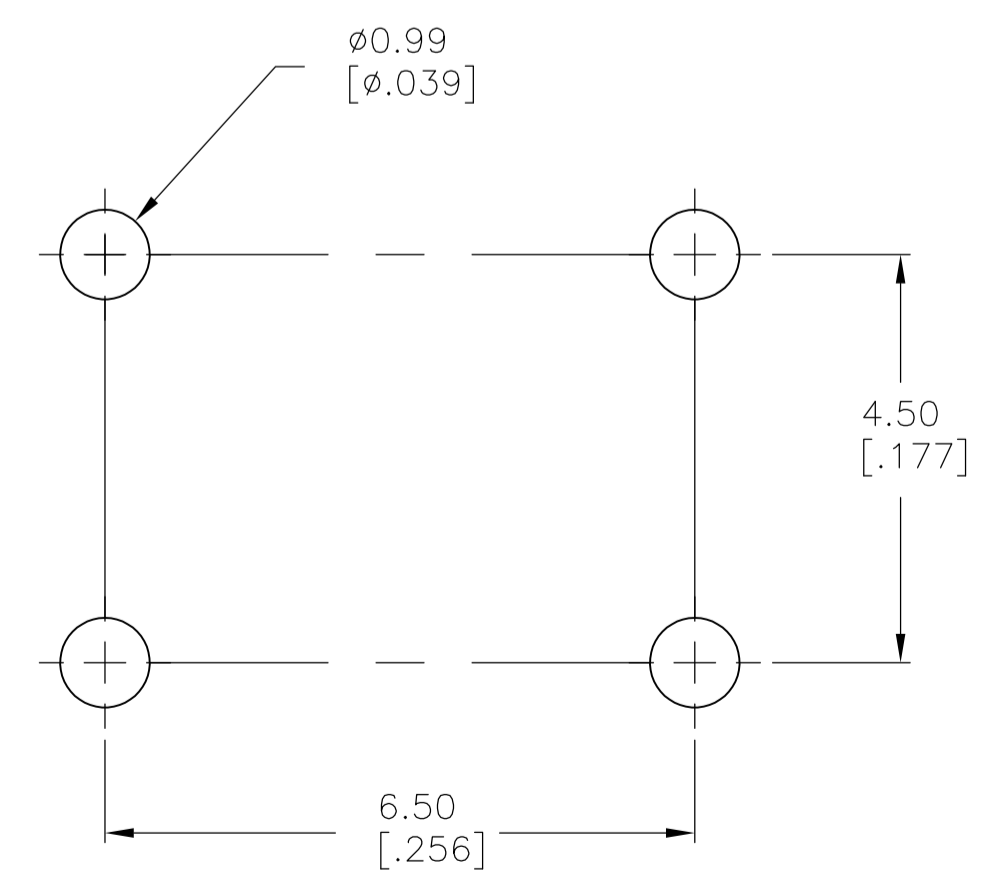
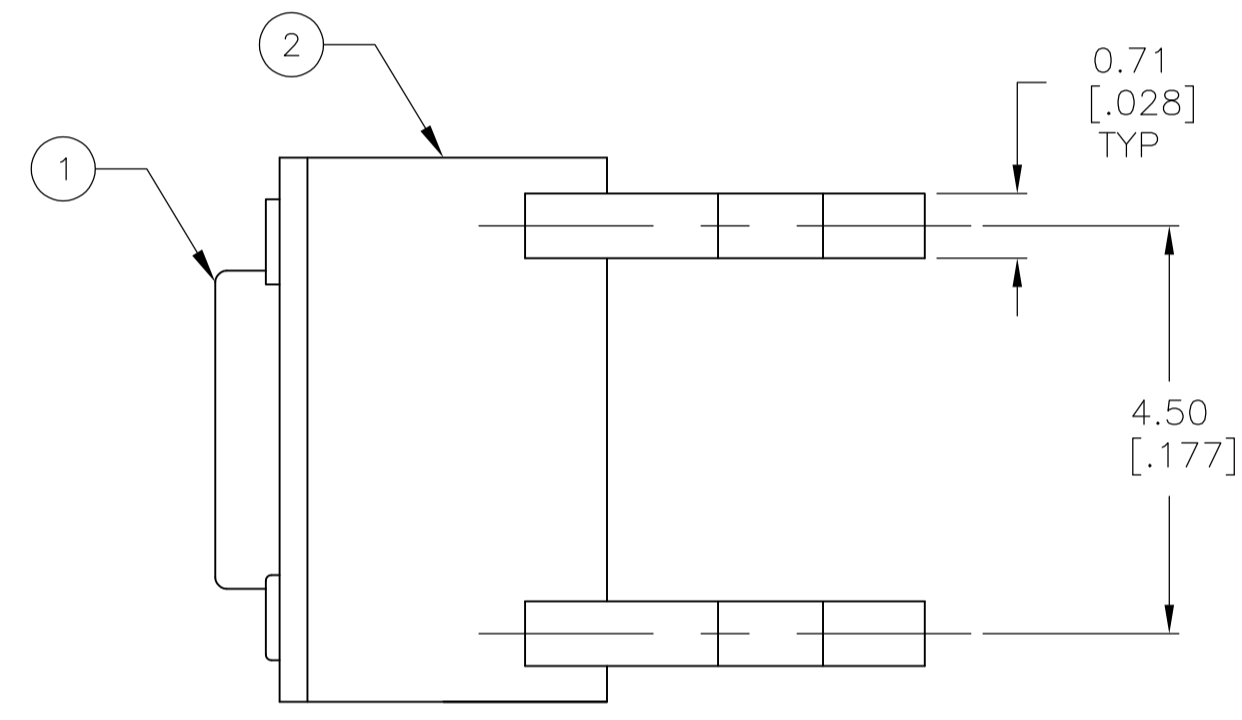

RECOMMENDED HOLE LAYOUT  
TOLERANCE ±0.05[.002] UNLESS OTHERWISE NOTED

CIRCUIT CHARACTERISTICS		
CONTACT POSITION	CIRCUIT DIAGRAM	
OFF		
(ON) 1-3 2-4		

	ACTUATOR MAT'L	ACTUATOR COLOR	ACTUATION FORCE	DIM C	DIM B	DIM A	ALCO P/N	TE P/N
OBSOLETE	NYLON 6T	YELLOW	520 +/-100 GF	3.09 (.122)	8.50 (.335)	4.90 (.193)	FSM18JAAHX	3-1977120-7
	NYLON 6T	WHITE	260 +/-50 GF	3.09 (.122)	8.50 (.335)	4.90 (.193)	FSM18JAHX	3-1977120-6
	PPS	BLACK	160 +/-50 GF	3.09 (.122)	8.50 (.335)	4.90 (.193)	FSM18JLHX	3-1977120-5
	PPS	BROWN	100 +/-50 GF	3.09 (.122)	8.50 (.335)	4.90 (.193)	FSM18JLHX	3-1977120-4
	NYLON 6T	YELLOW	520 +/-100 GF	2.80 (.110)	17.00 (.669)	13.40 (.527)	FSM16JAAHX	3-1977120-3
	NYLON 6T	WHITE	260 +/-50 GF	2.80 (.110)	17.00 (.669)	13.40 (.527)	FSM16JAHX	3-1977120-2
OBSOLETE	PPS	BLACK	160 +/-50 GF	2.80 (.110)	17.00 (.669)	13.40 (.527)	FSM16JHX	3-1977120-1
	PPS	BROWN	100 +/-50 GF	2.80 (.110)	17.00 (.669)	13.40 (.527)	FSM16JLHX	3-1977120-0
	NYLON 6T	YELLOW	520 +/-100 GF	2.87 (.118)	13.00 (.512)	9.40 (.370)	FSM14JAAHX	2-1977120-9
OBSOLETE	NYLON 6T	WHITE	260 +/-50 GF	2.87 (.118)	13.00 (.512)	9.40 (.370)	FSM14JAHX	2-1977120-8
	PPS	BLACK	160 +/-50 GF	2.87 (.118)	13.00 (.512)	9.40 (.370)	FSM14JHX	2-1977120-7
	PPS	BROWN	100 +/-50 GF	2.87 (.118)	13.00 (.512)	9.40 (.370)	FSM14JLHX	2-1977120-6
OBSOLETE	NYLON 6T	YELLOW	520 +/-100 GF	3.20 (.126)	8.00 (.315)	4.40 (.173)	FSM12JAAHX	2-1977120-5
	PPS	BLACK	260 +/-50 GF	3.20 (.126)	8.00 (.315)	4.40 (.173)	FSM12JABHX	2-1977120-4
	NYLON 6T	WHITE	260 +/-50 GF	3.20 (.126)	8.00 (.315)	4.40 (.173)	FSM12JAHX	2-1977120-3
OBSOLETE	PPS	BLACK	160 +/-50 GF	3.20 (.126)	8.00 (.315)	4.40 (.173)	FSM12JHX	2-1977120-2
OBSOLETE	PPS	BROWN	100 +/-50 GF	3.20 (.126)	8.00 (.315)	4.40 (.173)	FSM12JLHX	2-1977120-1
OBSOLETE	NYLON 6T	YELLOW	520 +/-100 GF	3.25 (.128)	7.30 (.287)	3.70 (.146)	FSM10JAAHX	2-1977120-0
	NYLON 6T	WHITE	260 +/-50 GF	3.25 (.128)	7.30 (.287)	3.70 (.146)	FSM10JAHX	1-1977120-9
	PPS	BLACK	160 +/-50 GF	3.25 (.128)	7.30 (.287)	3.70 (.146)	FSM10JHX	1-1977120-8
	PPS	BROWN	100 +/-50 GF	3.25 (.128)	7.30 (.287)	3.70 (.146)	FSM10JLHX	1-1977120-7
OBSOLETE	NYLON 6T	YELLOW	520 +/-100 GF	3.10 (.122)	9.50 (.374)	5.90 (.232)	FSM8JAAHX	1-1977120-6
	NYLON 6T	WHITE	260 +/-50 GF	3.10 (.122)	9.50 (.374)	5.90 (.232)	FSM8JAHX	1-1977120-5
	PPS	BLACK	160 +/-50 GF	3.10 (.122)	9.50 (.374)	5.90 (.232)	FSM8JHX	1-1977120-4
OBSOLETE	PPS	BROWN	100 +/-50 GF	3.10 (.122)	9.50 (.374)	5.90 (.232)	FSM8JLHX	1-1977120-3
	NYLON 6T	YELLOW	520 +/-100 GF	3.30 (.130)	7.00 (.276)	3.40 (.134)	FSM6JAAHX	1-1977120-2
	NYLON 6T	WHITE	260 +/-50 GF	3.30 (.130)	7.00 (.276)	3.40 (.134)	FSM6JAHX	1-1977120-1
OBSOLETE	PPS	BLACK	160 +/-50 GF	3.30 (.130)	7.00 (.276)	3.40 (.134)	FSM6JHX	1-1977120-0
	PPS	BROWN	100 +/-50 GF	3.30 (.130)	7.00 (.276)	3.40 (.134)	FSM6JLHX	1977120-9
	NYLON 6T	YELLOW	520 +/-100 GF	N/A	5.00 (.196)	1.40 (.055)	FSM4JAAHX	1977120-8
OBSOLETE	NYLON 6T	WHITE	260 +/-50 GF	N/A	5.00 (.196)	1.40 (.055)	FSM4JAHX	1977120-7
	PPS	BLACK	160 +/-50 GF	N/A	5.00 (.196)	1.40 (.055)	FSM4JHX	1977120-6
	PPS	BROWN	100 +/-50 GF	N/A	5.00 (.196)	1.40 (.055)	FSM4JLHX	1977120-5
OBSOLETE	NYLON 6T	YELLOW	520 +/-100 GF	N/A	4.30 (.169)	0.70 (.028)	FSM2JAAHX	1977120-4
	NYLON 6T	WHITE	260 +/-50 GF	N/A	4.30 (.169)	0.70 (.028)	FSM2JAHX	1977120-3
	PA6T	GRAY	160 +/-50 GF	N/A	4.30 (.169)	0.70 (.028)	FSM2JHX	1977120-2
OBSOLETE	PPS	BROWN	100 +/-50 GF	N/A	4.30 (.169)	0.70 (.028)	FSM2JLHX	1977120-1

THIS DRAWING IS A CONTROLLED DOCUMENT.

DIMENSIONS: mm [INCHES]	TOLERANCES UNLESS OTHERWISE SPECIFIED:	DIN M. BINNER 07JUN07	TE Connectivity
0 PLC ± -	1 PLC ± 0.30 [012]	07JUN07	6MM TACT SWITCH, THRU-HOLE HIGH TEMP
2 PLC ± -	3 PLC ± -	07JUN07	APPLICATION SPEC
4 PLC ± -	ANGLES ± -		SIZE: A1
MATERIAL: SEE SPECIFICATIONS	FINISH: -	WEIGHT: -	CAGE CODE: 00779
			DRAWING NO: 1977120
			RESTRICTED TO: -
			CUSTOMER DRAWING
			SCALE: 12:1
			SHEET: 1 OF 1
			REV: B4