

$\pm 2.5\text{ V} / 5\text{ V}$, 50 kSps, 24-bit, High-throughput $\Delta\Sigma$ ADC

Features

- ❑ Differential Analog Input
- ❑ On-chip Buffers for High Input Impedance
- ❑ Conversion Time = 20 μs
- ❑ Settles in One Conversion
- ❑ Linearity Error = 0.0005%
- ❑ Signal-to-Noise = 110 dB
- ❑ 24 Bits, No Missing Codes
- ❑ Simple three/four-wire serial interface
- ❑ Power Supply Configurations:
 - Analog: +5 V / GND; IO: +1.8 V to +3.3 V
 - Analog: $\pm 2.5\text{ V}$; IO: +1.8 V to +3.3 V
- ❑ Power Consumption:
 - ADC Input Buffers On: 90 mW
 - ADC Input Buffers Off: 60 mW

General Description

The CS5560 is a single-channel, 24-bit analog-to-digital converter capable of 50 kSps conversion rate. The input accepts a fully differential analog input signal. On-chip buffers provide high input impedance for both the AIN inputs and the VREF+ input. This significantly reduces the drive requirements of signal sources and reduces errors due to source impedances. The CS5560 is a delta-sigma converter capable of switching multiple input channels at a high rate with no loss in throughput. The ADC uses a low-latency digital filter architecture. The filter is designed for fast settling and settles to full accuracy in one conversion. The converter's 24-bit data output is in serial form, with the serial port acting as either a master or a slave. The converter is designed to support bipolar, ground-referenced signals when operated from $\pm 2.5\text{V}$ analog supplies.

The converter can operate from an analog supply of 0-5V or from $\pm 2.5\text{V}$. The digital interface supports standard logic operating from 1.8, 2.5, or 3.3 V.

ORDERING INFORMATION:

See [Ordering Information](#) on page 32.

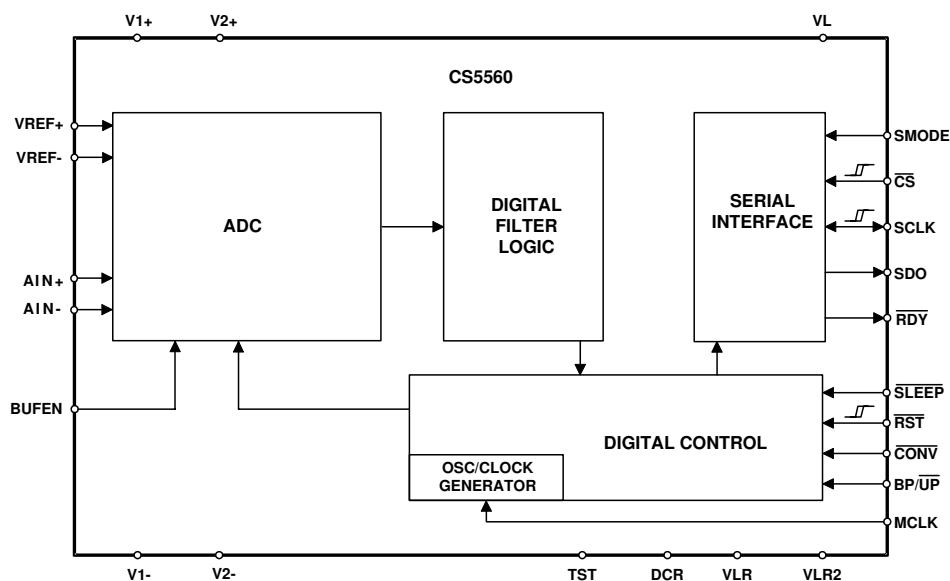

Preliminary Product Information

This document contains information for a new product. Cirrus Logic reserves the right to modify this product without notice.

TABLE OF CONTENTS

1. CHARACTERISTICS AND SPECIFICATIONS	4
ANALOG CHARACTERISTICS	4
SWITCHING CHARACTERISTICS	6
DIGITAL CHARACTERISTICS	10
DIGITAL FILTER CHARACTERISTICS	10
GUARANTEED LOGIC LEVELS	11
RECOMMENDED OPERATING CONDITIONS	12
ABSOLUTE MAXIMUM RATINGS	12
2. OVERVIEW	13
3. THEORY OF OPERATION	13
3.1 Converter Operation	13
3.2 Clock	15
3.3 Voltage Reference	15
3.4 Analog Input	16
3.5 Output Coding Format	16
3.6 Typical Connection Diagrams	17
3.7 AIN & VREF Sampling Structures	19
3.8 Converter Performance	19
3.9 Digital Filter Characteristics	23
3.10 Serial Port	24
3.10.1 SSC Mode	24
3.10.2 SEC Mode	24
3.11 Power Supplies & Grounding	25
3.12 Using the CS5560 in Multiplexing Applications	26
3.13 Synchronizing Multiple Converters	27
4. PIN DESCRIPTIONS	28
5. PACKAGE DIMENSIONS	31
6. ORDERING INFORMATION	32
7. ENVIRONMENTAL, MANUFACTURING, & HANDLING INFORMATION	32
8. REVISION HISTORY	32

LIST OF FIGURES

Figure 1. SSC Mode - Read Timing, CS remaining low	7
Figure 2. SSC Mode - Read Timing, CS falling after RDY falls	8
Figure 3. SEC Mode - Continuous SCLK Read Timing	9
Figure 4. SEC Mode - Discontinuous SCLK Read Timing	10
Figure 5. Voltage Reference Circuit	15
Figure 6. CS5560 Configured Using $\pm 2.5V$ Analog Supplies	17
Figure 7. CS5560 Configured Using a Single 5V Analog Supply	18
Figure 8. CS5560 DNL Plot.	19
Figure 9. Spectral Performance, 0 dB.	20
Figure 10. Spectral Performance, -6 dB	20
Figure 11. Spectral Performance, -12 dB	20
Figure 12. Spectral Performance, -20 dB	20
Figure 13. Spectral Performance, -40 dB	20
Figure 14. Spectral Performance, -100 dB	20
Figure 15. Spectral Performance, -120 dB	21
Figure 16. Spectral Performance, -130 dB	21
Figure 17. Spectral Plot of Noise with Shorted Input	22
Figure 18. Noise Histogram (32k Samples)	22
Figure 19. CS5560 Digital Filter Response (DC to $f_s/2$)	23
Figure 20. CS5560 Digital Filter Response (DC to 5 kHz)	23
Figure 21. CS5560 Digital Filter Response (DC to 4fs)	23
Figure 22. Simple Multiplexing Scheme	26
Figure 23. More Complex Multiplexing Scheme	27

LIST OF TABLES

Table 1. Output Coding, Two's Complement	16
Table 2. Output Coding, Offset Binary	16

1. CHARACTERISTICS AND SPECIFICATIONS

- Min / Max characteristics and specifications are guaranteed over the specified operating conditions.
- Typical characteristics and specifications are measured at nominal supply voltages and $T_A = 25^\circ\text{C}$.
- VLR = 0 V. All voltages with respect to 0 V.

ANALOG CHARACTERISTICS $T_A = -40$ to $+85^\circ\text{C}$; $V_{1+} = V_{2+} = +2.5$ V, $\pm 5\%$; $V_{1-} = V_{2-} = -2.5$ V, $\pm 5\%$; $V_L - V_{LR} = 3.3$ V, $\pm 5\%$; $V_{REF} = (V_{REF+}) - (V_{REF-}) = 4.096$ V; $MCLK = 16$ MHz; $S_{MODE} = V_L$. $BUFEN = V_{1+}$ unless otherwise stated. Connected per [Figure 6](#). Bipolar mode unless otherwise stated.

Parameter	Min	Typ	Max	Unit	
Accuracy					
Linearity Error	-	0.0005	-	$\pm\%$ FS	
Differential Linearity Error (Note 1, 2)	-	± 0.1	-	LSB_{24}	
Positive Full-scale Error	-	1.0	-	$\%$ FS	
Negative Full-scale Error	-	1.0	-	$\%$ FS	
Full-scale Drift (Note 2)	-	1	-	ppm / $^\circ\text{C}$	
Unipolar Offset (Note 2)	-	+2000	-	LSB_{24}	
Unipolar Offset Drift (Note 2)	-	2	-	$LSB / ^\circ\text{C}$	
Bipolar Offset (Note 2)	-	± 1000	-	LSB_{24}	
Bipolar Offset Drift (Note 2)	-	1	-	$LSB / ^\circ\text{C}$	
Noise	-	9.5	-	μV_{rms}	
Dynamic Performance					
Peak Harmonic or Spurious Noise	997 Hz, -0.5 dB Input	-	-111	-	dB
Total Harmonic Distortion	997 Hz, -0.5 dB Input	-	-108	-95	dB
Signal-to-Noise		108	110	-	dB
S/(N + D) Ratio	-0.5 dB Input, 997 Hz	95	109	-	dB
	-60 dB Input, 997 Hz	-	50	-	dB
-3 dB Input Bandwidth (Note 3)		-	42	-	kHz

1. No missing codes is guaranteed at 24 bits resolution over the specified temperature range.
2. One LSB is equivalent to $(2 \times V_{REF}) \div 2^{24}$ or $(2 \times 4.096) \div 16,777,216 = 488$ nV.
3. Scales with MCLK.

ANALOG CHARACTERISTICS (CONTINUED) $T_A = -40$ to $+85$ °C; $V_{1+} = V_{2+} = +2.5$ V, $\pm 5\%$; $V_{1-} = V_{2-} = -2.5$ V, $\pm 5\%$; $V_L - V_{LR} = 3.3$ V, $\pm 5\%$; $V_{REF} = (V_{REF+}) - (V_{REF-}) = 4.096$ V; $MCLK = 16$ MHz; $SMODE = V_L$.; $BUFEN = V_{1+}$ unless otherwise stated. Connected per [Figure 6](#).

Parameter		Min	Typ	Max	Unit
Analog Input					
Analog Input Range	Unipolar Bipolar		0 to +VREF $\pm V_{REF}$		V V
Input Capacitance		-	10	-	pF
CVF Current (Note 4)	AIN Buffer On ($BUFEN = V_{+}$)	-	600	-	nA
	AIN Buffer Off ($BUFEN = V_{-}$)	-	130	-	μ A
Common Mode Rejection Ratio (CMRR)		116	130	-	dB
Voltage Reference Input					
Voltage Reference Input Range (V_{REF+}) – (V_{REF-})	(Note 5)	2.4	4.096	4.2	V
Input Capacitance		-	10	-	pF
CVF Current	V_{REF+} Buffer On ($BUFEN = V_{+}$)	-	3	-	μ A
	V_{REF+} Buffer Off ($BUFEN = V_{-}$)	-	1	-	mA
	V_{REF-}	-	1	-	mA
Power Supplies					
DC Power Supply Currents	I_{V1}	-	-	19	mA
	I_{V2}	-	-	1.8	mA
	I_{VL}	-	-	0.6	mA
Power Consumption	Normal Operation Buffers On	-	90	106	mW
	Buffers Off	-	60	90	mW
Power Supply Rejection	(Note 6) V_{1+} , V_{2+} Supplies	60	70	-	dB
	V_{1-} , V_{2-} Supplies	60	70	-	dB

4. Measured using an input signal of 1 V DC.

5. For optimum performance, V_{REF+} should always be less than $(V_{+}) - 0.2$ volts to prevent saturation of the V_{REF+} input buffer.

6. Tested with 100 mVP-P on any supply up to 2 kHz. V_{1+} and V_{2+} supplies at the same voltage potential, V_{1-} and V_{2-} supplies at the same voltage potential.

SWITCHING CHARACTERISTICS

$T_A = -40$ to $+85$ °C; $V_{1+} = V_{2+} = +2.5$ V, $\pm 5\%$; $V_{1-} = V_{2-} = -2.5$ V, $\pm 5\%$;

$V_L - V_{LR} = 3.3$ V, $\pm 5\%$, 2.5 V, $\pm 5\%$, or 1.8 V, $\pm 5\%$

Input levels: Logic 0 = 0V = Low; Logic 1 = V_{D+} = High; $C_L = 15$ pF.

Parameter	Symbol	Min	Typ	Max	Unit	
Master Clock Frequency	Internal Oscillator	XIN	12	14	16	MHz
	External Clock	f_{clk}	0.5	16	16.2	MHz
Master Clock Duty Cycle		40	-	60	%	
Reset						
RST Low Time	t_{res}	1	-	-	μs	
RST rising to RDY falling	Internal Oscillator External Clock	t_{wup}	-	120	-	μs
			-	1536	-	MCLKs
Conversion						
CONV Pulse Width	t_{cpw}	4	-	-	MCLKs	
BP/UP setup to CONV falling	(Note 7)	t_{scn}	0	-	ns	
CONV low to start of conversion	t_{scn}	-	-	2	MCLKs	
Perform Single Conversion (CONV high before RDY falling)	t_{bus}	20	-	-	MCLKs	
Conversion Time	(Note 8) Start of Conversion to RDY falling	t_{buh}	-	-	324	MCLKs
Sleep Mode	SLEEP low to low-power state	t_{con}	-	50	-	μs
	SLEEP high to device active (Note 9)	t_{con}	-	3083	-	MCLKs

- BP/UP can be changed coincident CONV falling. BP/UP must remain stable until RDY falls.
- If CONV is held low continuously, conversions occur every 320 MCLK cycles.
If RDY is tied to CONV, conversions will occur every 322 MCLKs.
If CONV is operated asynchronously to MCLK, a conversion may take up to 324 MCLKs.
RDY falls at the end of conversion.
- RDY will fall when the device is fully operational when coming out of sleep mode.

SWITCHING CHARACTERISTICS (CONTINUED)
 $T_A = -40$ to $+85$ °C; $V_{1+} = V_{2+} = +2.5$ V, $\pm 5\%$; $V_{1-} = V_{2-} = -2.5$ V, $\pm 5\%$;

 $V_L - V_{LR} = 3.3$ V, $\pm 5\%$, 2.5 V, $\pm 5\%$, or 1.8 V, $\pm 5\%$

 Input levels: Logic 0 = 0V = Low; Logic 1 = V_{D+} = High; CL = 15 pF.

Parameter	Symbol	Min	Typ	Max	Unit
Serial Port Timing in SSC Mode (SMODE = VL)					
\overline{RDY} falling to MSB stable	t_1	-	-2	-	MCLKs
Data hold time after SCLK rising	t_2	-	10	-	ns
Serial Clock (Out) (Note 10, 11)	Pulse Width (low)	50	-	-	ns
	Pulse Width (high)	50	-	-	ns
\overline{RDY} rising after last SCLK rising	t_5	-	8	-	MCLKs

10. SDO and SCLK will be high impedance when \overline{CS} is high. In some systems SCLK and SDO may require pull-down resistors.
11. SCLK = MCLK/2.

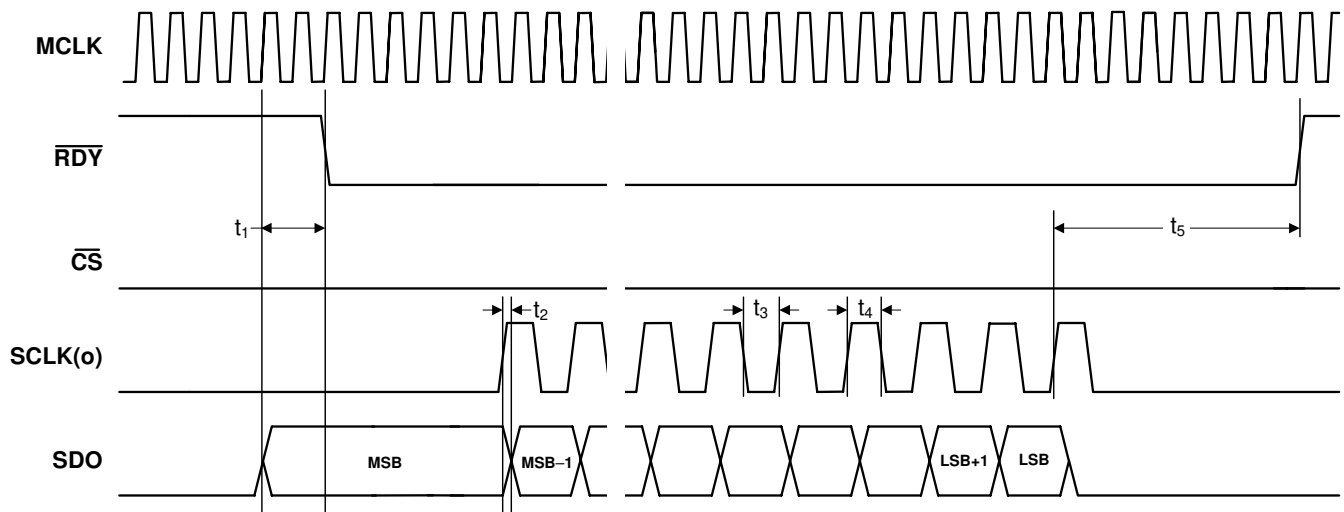
Figure 1. SSC Mode - Read Timing, \overline{CS} remaining low (Not to Scale)

SWITCHING CHARACTERISTICS (CONTINUED)
 $T_A = -40$ to $+85$ °C; $V_{1+} = V_{2+} = +2.5$ V, $\pm 5\%$; $V_{1-} = V_{2-} = -2.5$ V, $\pm 5\%$;

 $V_L - V_{LR} = 3.3$ V, $\pm 5\%$, 2.5 V, $\pm 5\%$, or 1.8 V, $\pm 5\%$

 Input levels: Logic 0 = 0V = Low; Logic 1 = V_{D+} = High; $C_L = 15$ pF.

Parameter	Symbol	Min	Typ	Max	Unit
Serial Port Timing in SSC Mode (SMODE = VL)					
Data hold time after SCLK rising	t_7	-	10	-	ns
Serial Clock (Out) (Note 12, 13)	Pulse Width (low)	50	-	-	ns
	Pulse Width (high)	50	-	-	ns
\overline{RDY} rising after last SCLK rising	t_{10}	-	8	-	MCLKs
\overline{CS} falling to MSB stable	t_{11}	-	10	-	ns
First SCLK rising after \overline{CS} falling	t_{12}	-	8	-	MCLKs
\overline{CS} hold time (low) after SCLK rising	t_{13}	10	-	-	ns
SCLK, SDO tristate after \overline{CS} rising	t_{14}	-	5	-	ns

12. SDO and SCLK will be high impedance when \overline{CS} is high. In some systems it may require a pull-down resistor.
13. $SCLK = MCLK/2$.

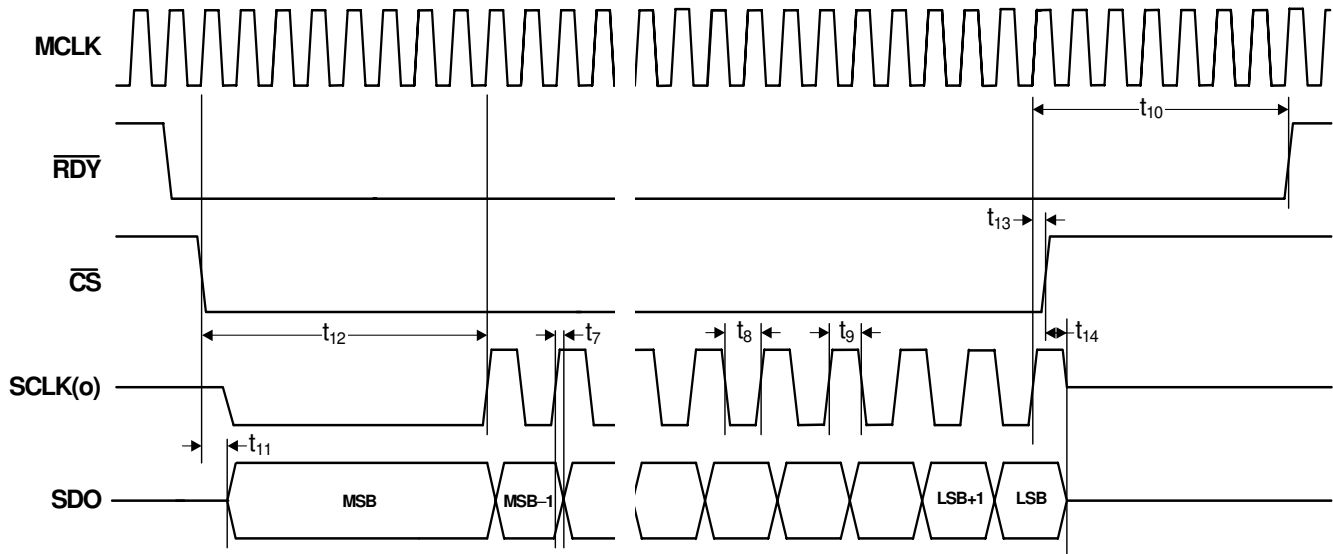
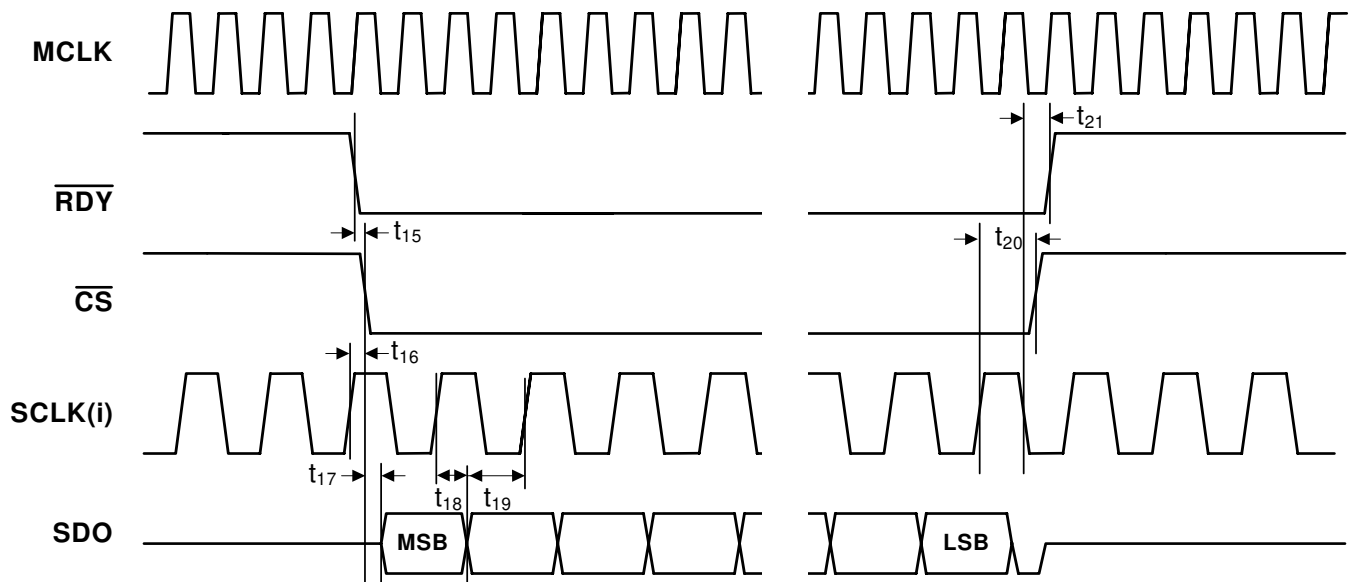

Figure 2. SSC Mode - Read Timing, \overline{CS} falling after \overline{RDY} falls (Not to Scale)

SWITCHING CHARACTERISTICS (CONTINUED)
 $T_A = -40$ to $+85$ °C; $V_{1+} = V_{2+} = +2.5$ V, $\pm 5\%$; $V_{1-} = V_{2-} = -2.5$ V, $\pm 5\%$;

 $V_L - V_{LR} = 3.3$ V, $\pm 5\%$, 2.5 V, $\pm 5\%$, or 1.8 V, $\pm 5\%$

 Input levels: Logic 0 = 0V = Low; Logic 1 = V_{D+} = High; CL = 15 pF.

Parameter	Symbol	Min	Typ	Max	Unit
Serial Port Timing in SEC Mode (SMODE = VLR)					
SCLK(in) Pulse Width (High)	-	30	-	-	ns
SCLK(in) Pulse Width (Low)	-	30	-	-	ns
\overline{CS} hold time (high) after \overline{RDY} falling	t_{15}	10	-	-	ns
\overline{CS} hold time (high) after SCLK rising	t_{16}	10	-	-	ns
\overline{CS} low to SDO out of Hi-Z (Note 14)	t_{17}	-	10	-	ns
Data hold time after SCLK rising	t_{18}	-	10	-	ns
Data setup time before SCLK rising	t_{19}	10	-	-	ns
\overline{CS} hold time (low) after SCLK rising	t_{20}	10	-	$\frac{1}{SCLK} - 10$	ns
\overline{RDY} rising after SCLK falling	t_{21}	-	10	-	ns

 14. SDO will be high impedance when \overline{CS} is high. In some systems it may require a pull-down resistor.

Figure 3. SEC Mode - Continuous SCLK Read Timing (Not to Scale)

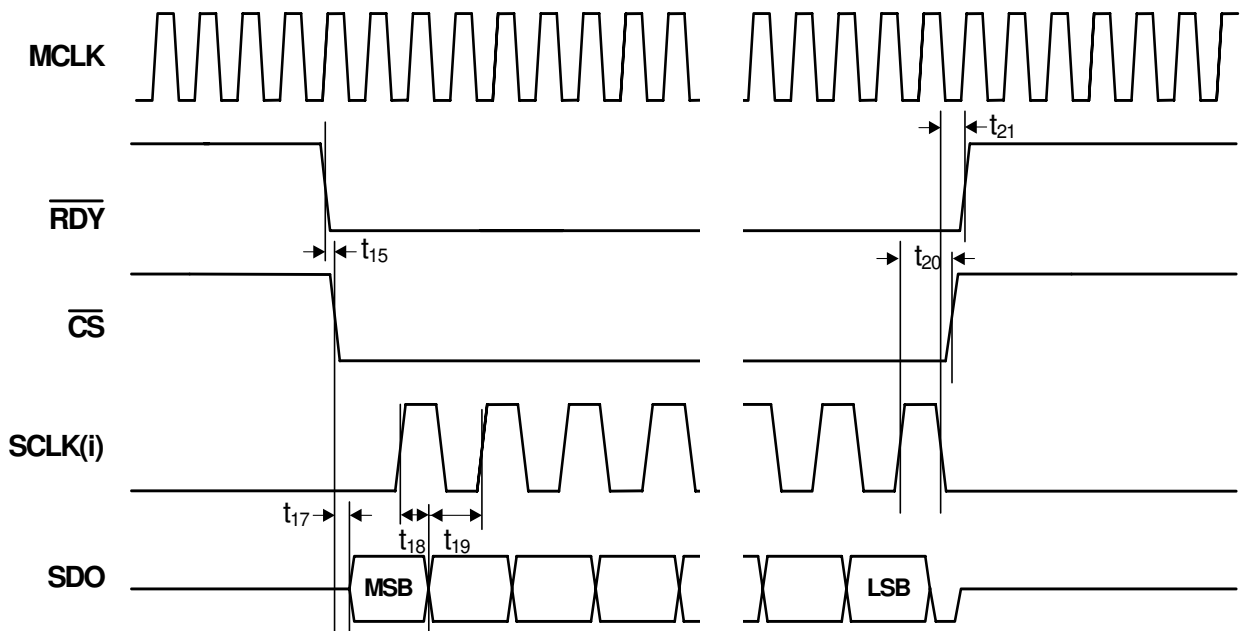

Figure 4. SEC Mode - Discontinuous SCLK Read Timing (Not to Scale)

DIGITAL CHARACTERISTICS

$T_A = T_{MIN}$ to T_{MAX} ; $V_L = 3.3V, \pm 5\%$ or $V_L = 2.5V, \pm 5\%$ or $1.8V, \pm 5\%$; $V_{LR} = 0V$

Parameter	Symbol	Min	Typ	Max	Unit
Input Leakage Current	I_{in}	-	-	2	μA
Digital Input Pin Capacitance	C_{in}	-	3	-	pF
Digital Output Pin Capacitance	C_{out}	-	3	-	pF

DIGITAL FILTER CHARACTERISTICS

$T_A = T_{MIN}$ to T_{MAX} ; $V_L = 3.3V, \pm 5\%$ or $V_L = 2.5V, \pm 5\%$ or $1.8V, \pm 5\%$; $V_{LR} = 0V$

Parameter	Symbol	Min	Typ	Max	Unit
Group Delay	-	-	160	-	MCLKs

GUARANTEED LOGIC LEVELS

$T_A = -40$ to $+85$ °C; $V_{1+} = V_{2+} = +2.5$ V, $\pm 5\%$; $V_{1-} = V_{2-} = -2.5$ V, $\pm 5\%$;

VL - VLR = 3.3 V, $\pm 5\%$, 2.5 V, $\pm 5\%$, or 1.8 V, $\pm 5\%$

Input levels: Logic 0 = 0V = Low; Logic 1 = V_{D+} = High; $C_L = 15$ pF.

Parameter	Sym	VL	Guaranteed Limits			Unit	Conditions
			Min	Typ	Max		
Logic Inputs							
Minimum High-level Input Voltage:	V_{IH}	3.3	1.9			V	
		2.5	1.6				
		1.8	1.2				
Maximum Low-level Input Voltage:	V_{IL}	3.3			1.1	V	
		2.5			0.95		
		1.8			0.6		
Logic Outputs							
Minimum High-level Output Voltage:	V_{OH}	3.3	2.9			V	$I_{OH} = -2$ mA
		2.5	2.1				
		1.8	1.65				
Maximum Low-level Output Voltage:	V_{OL}	3.3			0.36	V	$I_{OH} = -2$ mA
		2.5			0.36		
		1.8			0.44		

RECOMMENDED OPERATING CONDITIONS

(VLR = 0V, see Note 15)

Parameter	Symbol	Min	Typ	Max	Unit	
Single Analog Supply						
DC Power Supplies:	(Note 15)					
V1+	V1+	4.75	5.0	5.25	V	
V2+	V2-	4.75	5.0	5.25	V	
V1-	V1+	-	0	-	V	
V2-	V2-	-	0	-	V	
Dual Analog Supplies						
DC Power Supplies:	(Note 15)					
V1+	V1+	+2.375	+2.5	+2.625	V	
V2+	V2-	+2.375	+2.5	+2.625	V	
V1-	V1+	-2.375	-2.5	-2.625	V	
V2-	V2-	-2.375	-2.5	-2.625	V	
Analog Reference Voltage	(Note 16) [VREF+] – [VREF-]	VREF	2.4	4.096	4.2	V

15. The logic supply can be any value VL – VLR = +1.71 to +3.465 volts as long as VLR ≥ V2- and VL ≤ 3.465 V.

16. The differential voltage reference magnitude is constrained by the V1+ or V1- supply magnitude.

ABSOLUTE MAXIMUM RATINGS

(VLR = 0V)

Parameter	Symbol	Min	Typ	Max	Unit
DC Power Supplies:					
[V1+] – [V1-] (Note 17)	-	0	-	5.5	V
VL + [V1-] (Note 18)	-	0	-	6.1	V
Input Current, Any Pin Except Supplies	(Note 19) I _{IN}	-	-	±10	mA
Analog Input Voltage	(AIN and VREF pins) V _{INA}	(V1-) – 0.3	-	(V1+) + 0.3	V
Digital Input Voltage	V _{IND}	VLR – 0.3	-	VL + 0.3	V
Storage Temperature	T _{stg}	-65	-	150	°C

Notes: 17. V1+ = V2+; V1- = V2-

18. V1- = V2-

19. Transient currents of up to 100 mA will not cause SCR latch-up.

WARNING:

Recommended Operating Conditions indicate limits to which the device is functionally operational. Absolute Maximum Ratings indicate limits beyond which permanent damage to the device may occur. The Absolute Maximum Ratings are stress ratings only and the device should not be operated at these limits. Operation at conditions beyond the Recommended Operating Conditions may affect device reliability, and functional operation beyond Recommended Operating Conditions is not implied. Performance specifications are intended for the conditions specified for each table in the Characteristics and Specifications section.

2. OVERVIEW

The CS5560 is a 24-bit analog-to-digital converter capable of 50 kSps conversion rate. The device is capable of switching multiple input channels at a high rate with no loss in throughput. The ADC uses a low-latency digital filter architecture. The filter is designed for fast settling and settles to full accuracy in one conversion.

The converter is a serial output device. The serial port can be configured to function as either a master or a slave.

The converter can operate from an analog supply of 5V or from $\pm 2.5V$. The digital interface supports standard logic operating from 1.8, 2.5, or 3.3 V.

The CS5560 converts at 50 kSps when operating from a 16 MHz input clock.

3. THEORY OF OPERATION

The converter should be reset after the power supplies and voltage reference are stable.

The CS5560 converter provides high-performance measurement of DC or AC signals. The converter can be used to perform single conversions or continuous conversions upon command. Each conversion is independent of previous conversions and can settle to full specified accuracy, even with a full-scale input voltage step. This is due to the converter architecture which uses a combination of a high-speed delta-sigma modulator and a low-latency filter architecture.

Once power is established to the converter, a reset must be performed. A reset initializes the internal converter logic.

If $\overline{\text{CONV}}$ is held low, the converter will convert continuously with $\overline{\text{RDY}}$ falling every 320 MCLKs. This is equivalent to 50 kSps if $\text{MCLK} = 16.0 \text{ MHz}$. If $\overline{\text{CONV}}$ is tied to $\overline{\text{RDY}}$, a conversion will occur every 322 MCLKs. If $\overline{\text{CONV}}$ is operated asynchronously to MCLK, it may take up to 324 MCLKs from $\overline{\text{CONV}}$ falling to $\overline{\text{RDY}}$ falling.

Multiple converters can operate synchronously if they are driven by the same MCLK source and $\overline{\text{CONV}}$ to each converter falls on the same MCLK falling edge. Alternately, $\overline{\text{CONV}}$ can be held low and all devices can be synchronized if they are reset with $\overline{\text{RST}}$ rising on the same falling edge of MCLK.

The output coding of the conversion word is a function of the $\text{BP}/\overline{\text{UP}}$ pin.

The active-low $\overline{\text{SLEEP}}$ signal causes the device to enter a low-power state. When exiting sleep, the converter will take 3083 MCLK cycles before conversions can be performed. $\overline{\text{RST}}$ should remain inactive (high) when $\overline{\text{SLEEP}}$ is asserted (low).

3.1 Converter Operation

The CS5560 converts at 50 kSps when synchronously operated ($\overline{\text{CONV}} = \text{VLR}$) from a 16.0 MHz master clock. Conversion is initiated by taking $\overline{\text{CONV}}$ low. A conversion lasts 320 master clock cycles, but if $\overline{\text{CONV}}$ is asynchronous to MCLK there may be an uncertainty of 0-4 MCLK cycles after $\overline{\text{CONV}}$ falls to when a conversion actually begins. This may extend the throughput to 324 MCLKs

When the conversion is completed, the output word is placed into the serial port and $\overline{\text{RDY}}$ goes low. To convert continuously, $\overline{\text{CONV}}$ should be held low. In continuous conversion mode with $\overline{\text{CONV}}$ held low, a conversion is performed in 320 MCLK cycles. Alternately $\overline{\text{RDY}}$ can be tied to $\overline{\text{CONV}}$ and a conversion will occur every 322 MCLK cycles.

To perform only one conversion, $\overline{\text{CONV}}$ should return high at least 20 master clock cycles before $\overline{\text{RDY}}$ falls.

Once a conversion is completed and $\overline{\text{RDY}}$ falls, $\overline{\text{RDY}}$ will return high when all the bits of the data word are emptied from the serial port or if the conversion data is not read and $\overline{\text{CS}}$ is held low, $\overline{\text{RDY}}$ will go high two MCLK cycles before the end of conversion. $\overline{\text{RDY}}$ will fall at the end of the next conversion when new data is put into the port register.

See [Serial Port](#) on page 24 for information about reading conversion data.

Conversion performance can be affected by several factors. These include the choice of clock source for the chip, the timing of $\overline{\text{CONV}}$, and the choice of the serial port mode.

The converter can be operated from an internal oscillator. This clock source has greater jitter than an external crystal-based clock. Jitter may not be an issue when measuring DC signals, or very-low-frequency AC signals, but can become an issue for higher frequency AC signals. For maximum performance when digitizing AC signals, a low-jitter MCLK should be used.

To maximize performance, the $\overline{\text{CONV}}$ pin should be held low in the continuous conversion state to perform multiple conversions, or $\overline{\text{CONV}}$ should occur synchronous to MCLK, falling when MCLK falls.

If the converter is operated at maximum throughput, the SSC serial port mode is less likely to cause interference to measurements as the SCLK output is synchronized to the MCLK. Alternately, any interference due to serial port clocking can also be minimized if data is read in the SEC serial port mode when a conversion is not in progress.

3.2 Clock

The CS5560 can be operated from its internal oscillator or from an external master clock. The state of MCLK determines which clock source will be used. If MCLK is tied low, the internal oscillator will start and be used as the clock source for the converter. If an external CMOS-compatible clock is input into MCLK the converter will power down the internal oscillator and use the external clock. If the MCLK pin is held high, the internal oscillator will be held in the stopped state. The MCLK input can be held high to delete clock cycles to aid in synchronizing multiple converters in different phase relationships.

The internal oscillator can be used if the signals to be measured are essentially DC. The internal oscillator exhibits jitter at about 500 picoseconds rms. If the CS5560 is used to digitize AC signals, an external low-jitter clock source should be used.

If the internal oscillator is used as the clock for the CS5560, the maximum conversion rate will be dictated by the oscillator frequency.

If driven from an external MCLK source, the fast rise and fall times of the MCLK signal can result in clock coupling from the internal bond wire of the IC to the analog input. Adding a 50 ohm resistor on the external MCLK source significantly reduces this effect.

3.3 Voltage Reference

The voltage reference for the CS5560 can range from 2.4 volts to 4.2 volts. A 4.096 volt reference is required to achieve the specified performance. [Figure 6](#) and [Figure 7](#) illustrate the connection of the voltage reference with either a single +5 V analog supply or with ± 2.5 V.

For optimum performance, the voltage reference device should be one that provides a capacitor connection to provide a means of noise filtering, or the output should include some type of bandwidth-limiting filter. Some 4.096 volt reference devices need only 5 volts total supply for operation and can be connected as shown in [Figure 6](#) or [Figure 7](#). The reference should have a local bypass capacitor and an appropriate output capacitor.

Some older 4.096 volt reference designs require more headroom and must operate from an input voltage of 5.5 to 6.5 volts. If this type of voltage reference is used ensure that when power is applied to the system, the voltage reference rise time is slower than the rise time of the V1+ and V1- power supply voltage to the converter. An example circuit to slow the output startup time of the reference is illustrated in [Figure 5](#).

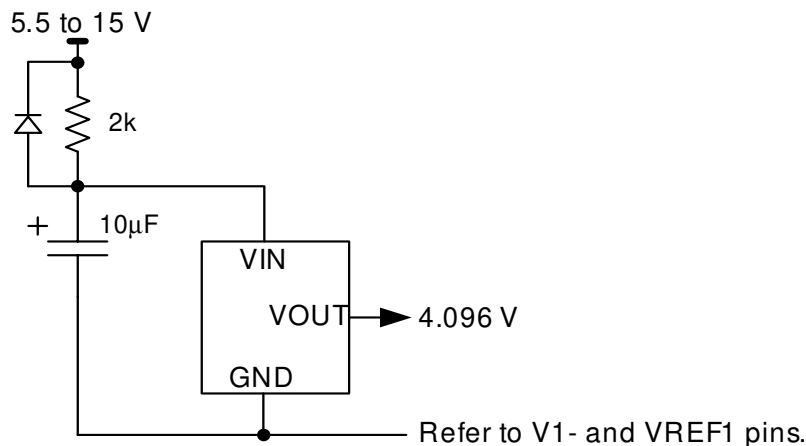

Figure 5. Voltage Reference Circuit

3.4 Analog Input

The analog input of the converter is fully differential with a peak-to-peak input of 4.096 volts on each input. Therefore, the differential, peak-to-peak input is 8.192 volts. This is illustrated in [Figure 6](#) and [Figure 7](#). These diagrams also illustrate a differential buffer amplifier configuration for driving the CS5560.

The capacitors at the outputs of the amplifiers provide a charge reservoir for the dynamic current from the A/D inputs while the resistors isolate the dynamic current from the amplifier. The amplifiers can be powered from higher supplies than those used by the A/D but precautions should be taken to ensure that the op amp output voltage remains within the power supply limits of the A/D, especially under start-up conditions.

3.5 Output Coding Format

The reference voltage directly defines the input voltage range in both the unipolar and bipolar configurations. In the unipolar configuration (BP/UP low), the first code transition occurs 0.5 LSB above zero, and the final code transition occurs 1.5 LSBs below VREF. In the bipolar configuration (BP/UP high), the first code transition occurs 0.5 LSB above -VREF and the last transition occurs 1.5 LSBs below +VREF. See [Table 1](#) for the output coding of the converter.

Table 1. Output Coding, Two's Complement

Bipolar Input Voltage	Two's Complement
>(VREF-1.5 LSB)	7F FF FF
VREF-1.5 LSB	7F FF FF 7F FF FE
-0.5 LSB	00 00 00 FF FF FF
-VREF+0.5 LSB	80 00 01 80 00 00
<(-VREF+0.5 LSB)	80 00 00

NOTE: VREF = (VREF+) - (VREF-)

Table 2. Output Coding, Offset Binary

Unipolar Input Voltage	Offset Binary
>(VREF-1.5 LSB)	FF FF FF
VREF-1.5 LSB	FF FF FF FF FF FE
(VREF/2)-0.5 LSB	80 00 00 7F FF FF
+0.5 LSB	00 00 01 00 00 00
<(0.5 LSB)	00 00 00

NOTE: VREF = (VREF+) - (VREF-)

3.6 Typical Connection Diagrams

The following figure depicts the CS5560 powered from bipolar analog supplies, +2.5 V and - 2.5 V.

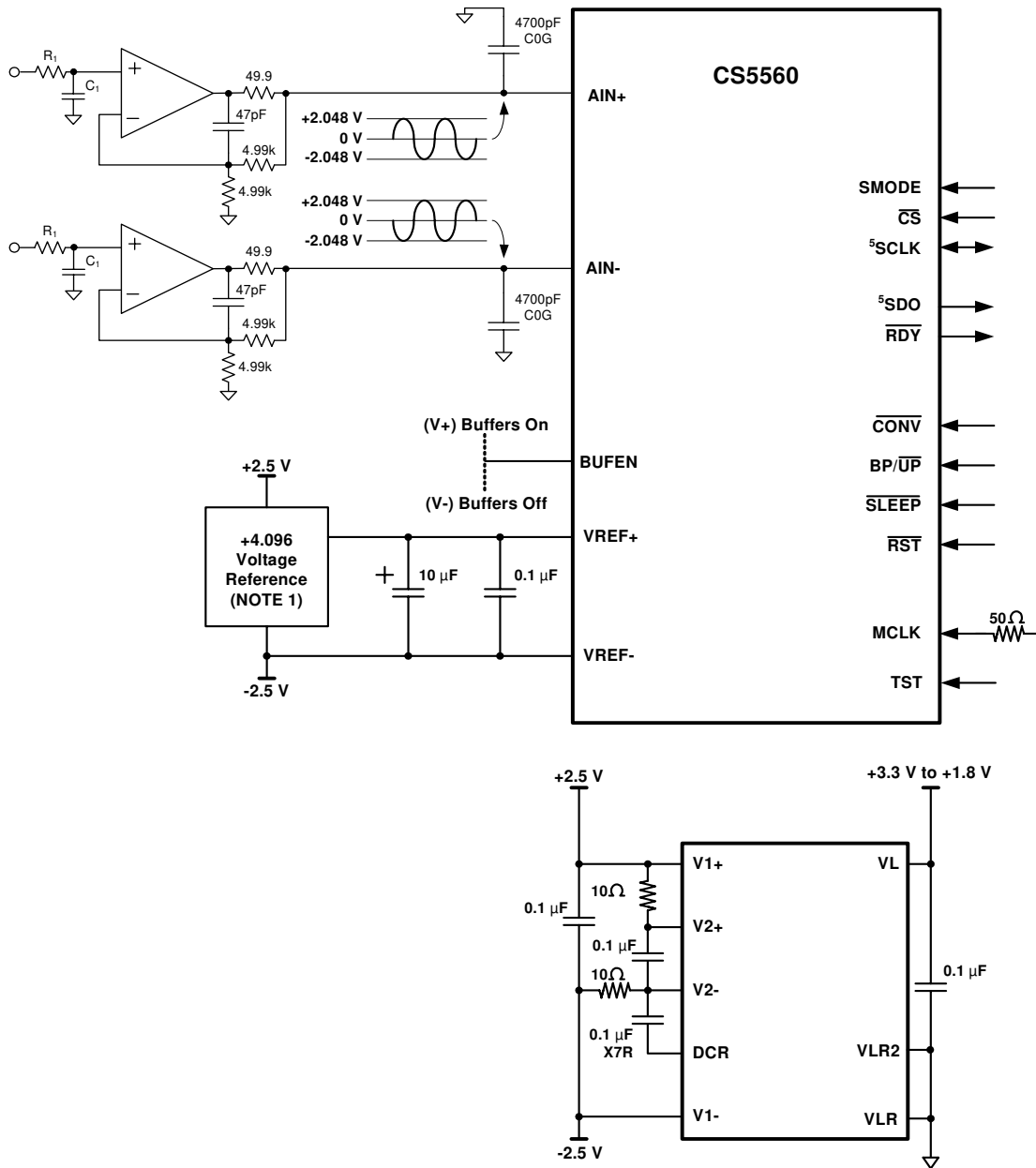

NOTES

1. See Section 3.3 Voltage Reference for information on required voltage reference performance criteria.
2. Locate capacitors so as to minimize loop length.
3. The ± 2.5 V supplies should also be bypassed to ground at the converter.
4. VLR and the power supply ground for the ± 2.5 V should be connected to the same ground plane under the chip.
5. SCLK and SDO may require pull-down resistors in some applications.
6. An RC input filter can be used to band limit the input to reduce noise. Select R to be equal to the parallel combination of the feedback of the feedback resistors $4.99k \parallel 4.99k = 2.5k \pm$

Figure 6. CS5560 Configured Using ± 2.5 V Analog Supplies

The following figure depicts the CS5560 device powered from a single 5V analog supply.

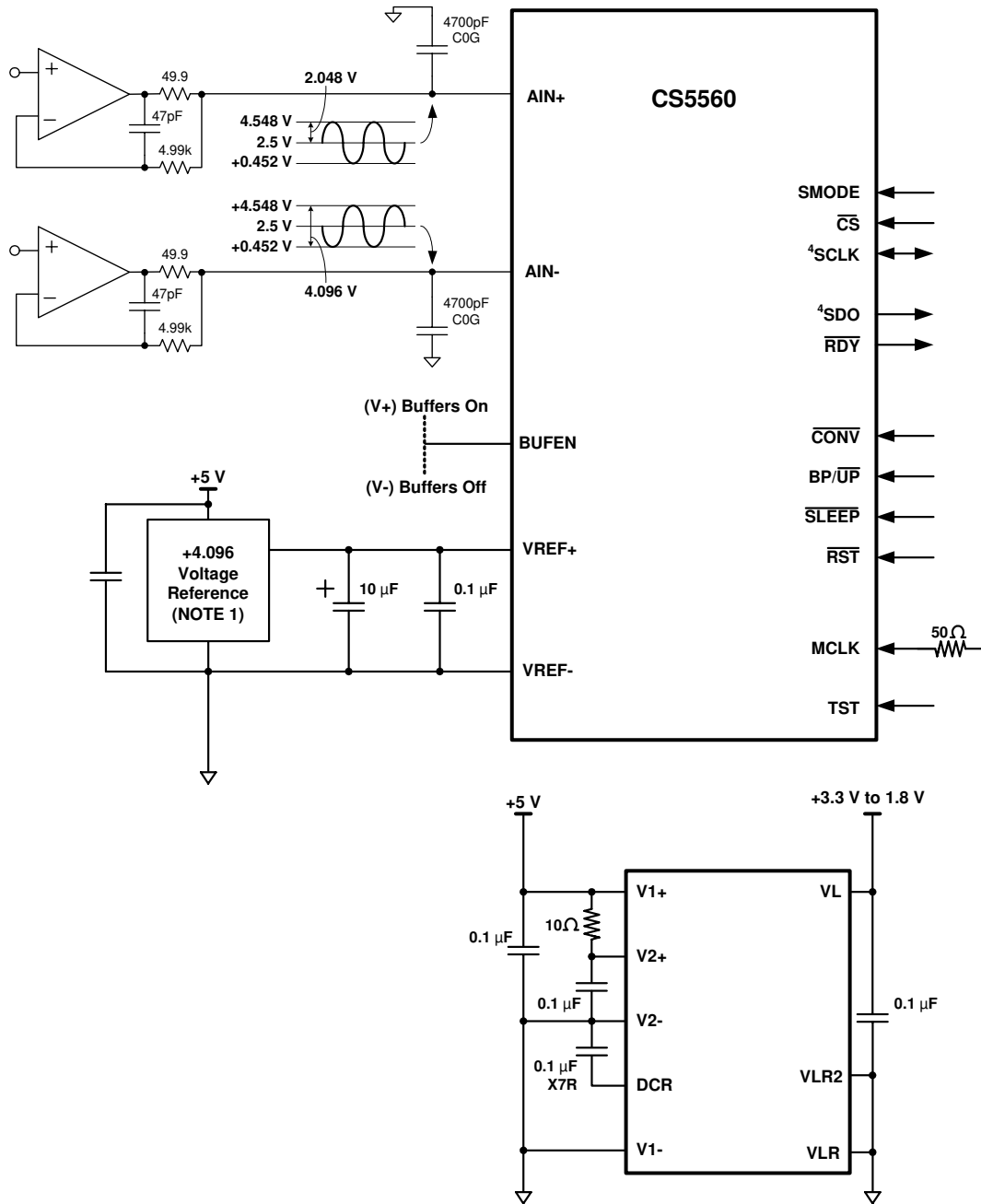

NOTES

1. See Section 3.3 Voltage Reference for information on required voltage reference performance criteria.
2. Locate capacitors so as to minimize loop length.
3. V1-, V2-, and VLR should be connected to the same ground plane under the chip.
4. SCLK and SDO may require pull-down resistors in some applications.

Figure 7. CS5560 Configured Using a Single 5V Analog Supply

3.7 AIN & VREF Sampling Structures

The CS5560 uses on-chip buffers on the AIN+, AIN-, and the VREF+ inputs. Buffers provide much higher input impedance and therefore reduce the amount of drive current required from an external source. This helps minimize errors.

The Buffer Enable (BUFEN) pin determines if the on-chip buffers are used or not. If the BUFEN pin is connected to the V1+ supply, the buffers will be enabled. If the BUFEN pin is connected to the V1- pin, the buffers are off. The converter will consume about 30 mW less power when the buffers are off, but the input impedances of AIN+, AIN- and VREF+ will be significantly less than with the buffers enabled.

3.8 Converter Performance

The CS5560 achieves excellent differential nonlinearity (DNL) as shown in Figure 8. Figure 8 illustrates the code widths on the typical scale of ± 1 LSB and on a zoomed scale of ± 0.2 LSB.

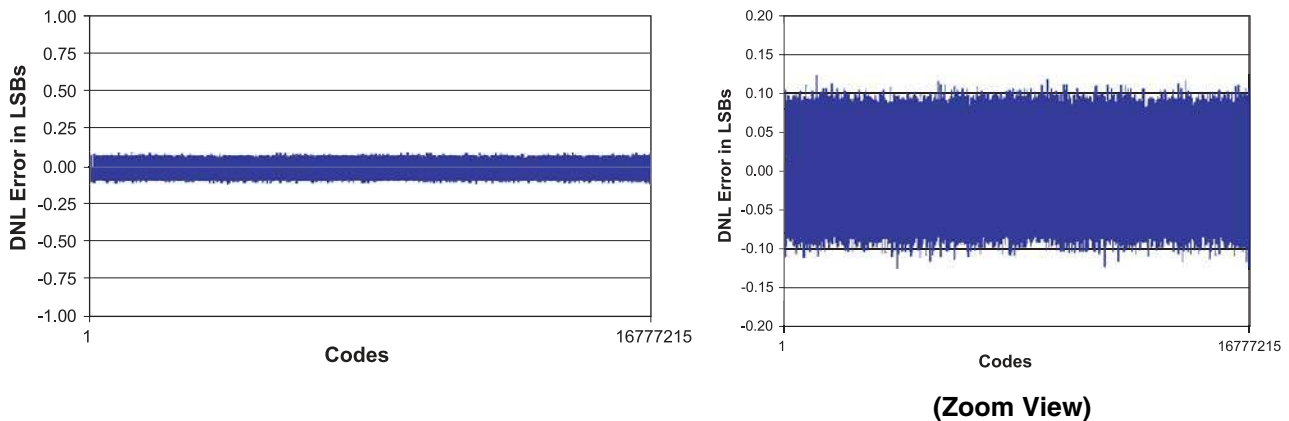

Figure 8. CS5560 DNL Plot

Figure 9 through Figure 16 illustrate the performance of the converter with various input signal magnitudes.

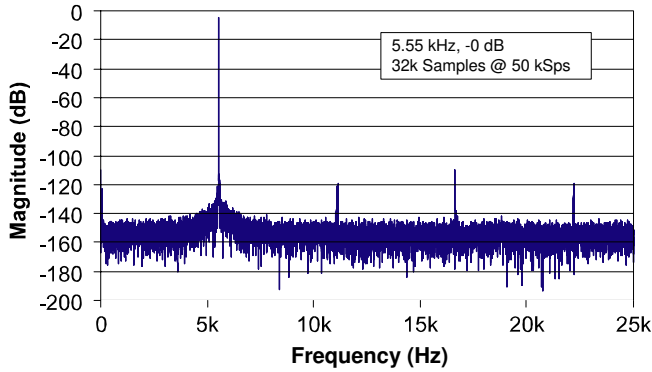

Figure 9. Spectral Performance, 0 dB

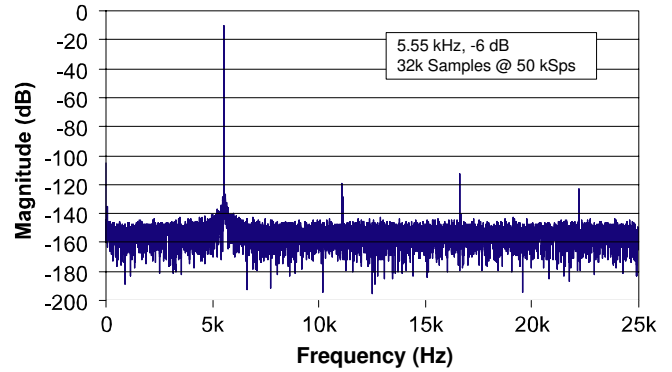

Figure 10. Spectral Performance, -6 dB

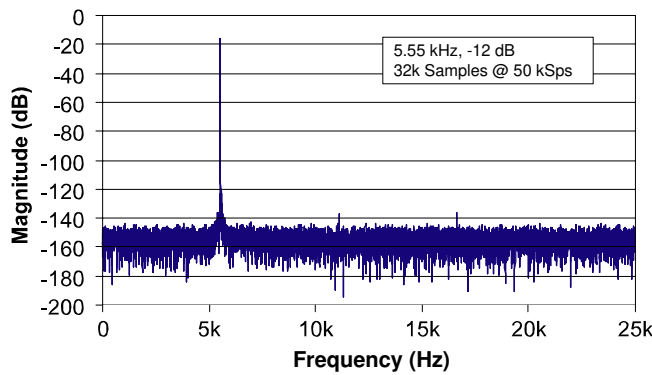

Figure 11. Spectral Performance, -12 dB

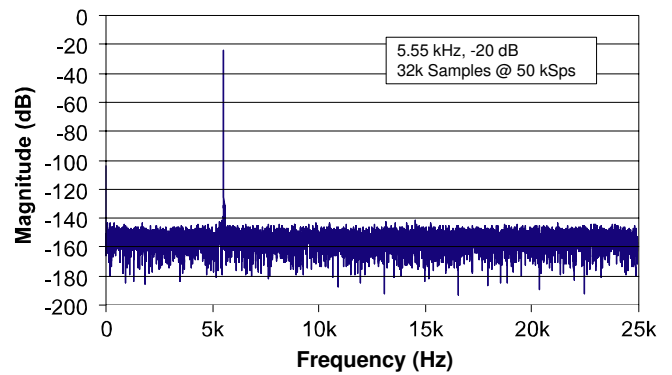

Figure 12. Spectral Performance, -20 dB

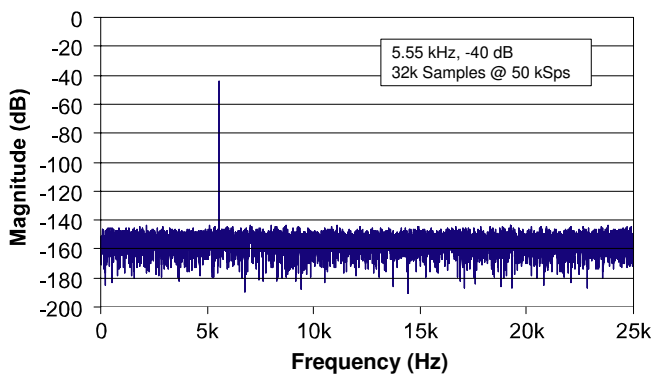

Figure 13. Spectral Performance, -40 dB

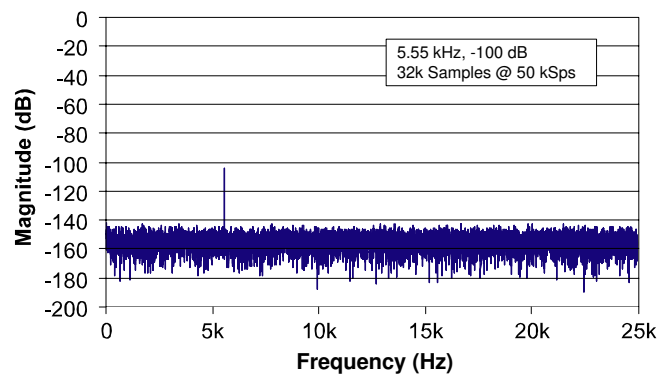

Figure 14. Spectral Performance, -100 dB

Figure 15 illustrates the device with a small signal 1/1,000,000 of full scale. The signal input for figure 14 is about 8.2 microvolts peak to peak, or about 17 codes peak to peak. Figure 16 illustrates the converter with a signal at about 2.6 microvolts peak to peak, or about 5 codes peak to peak. The CS5560 achieves superb performance with this small signal. And the noise floor exhibits no spurious components due to digital interference from the on chip logic.

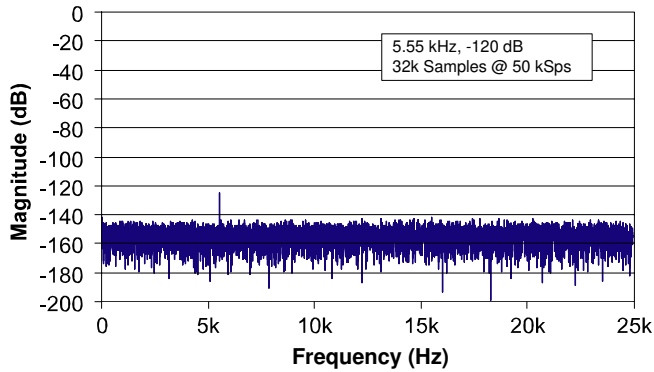

Figure 15. Spectral Performance, -120 dB

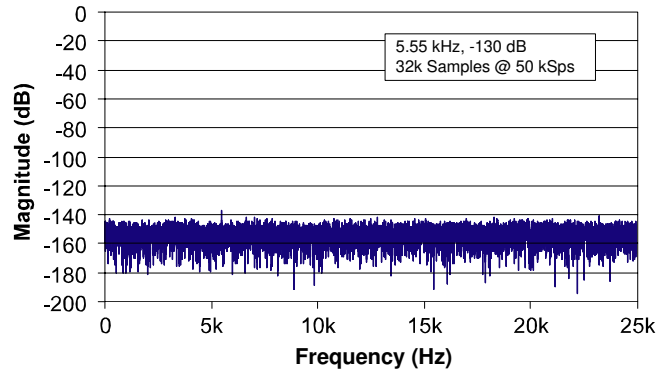

Figure 16. Spectral Performance, -130 dB

Figure 17 illustrates the noise floor of the converter from 0.1 Hz to 25 kHz. While the plot does exhibit some 1/f noise at lower frequencies, the noise floor is entirely free of spurious frequency content due to digital activity inside the chip.

Figure 16 illustrates a noise histogram of 32,768 samples.

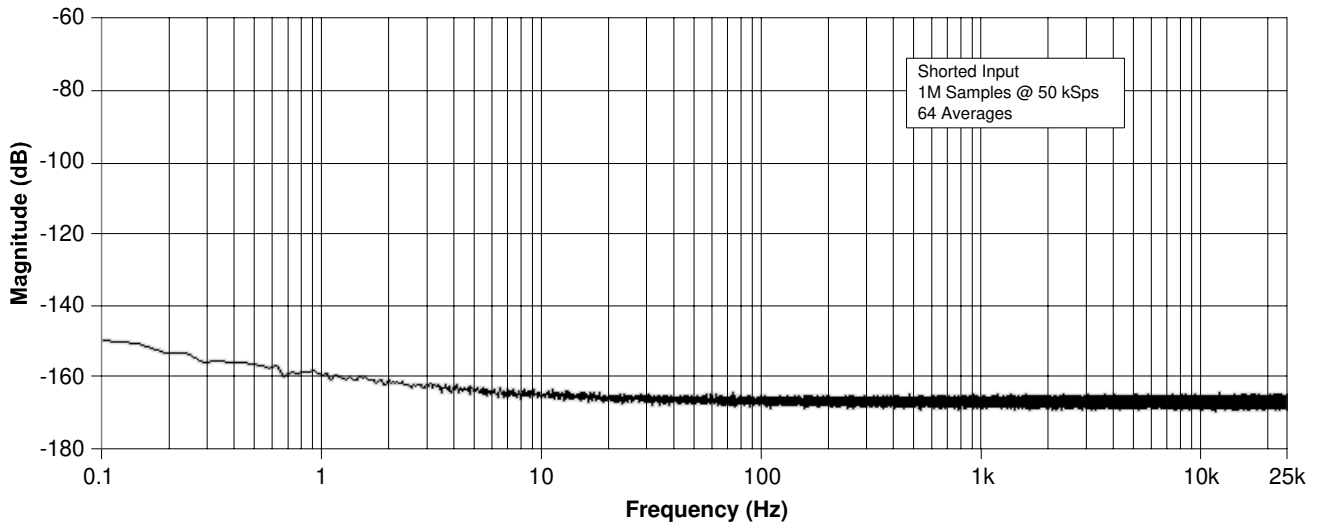

Figure 17. Spectral Plot of Noise with Shorted Input

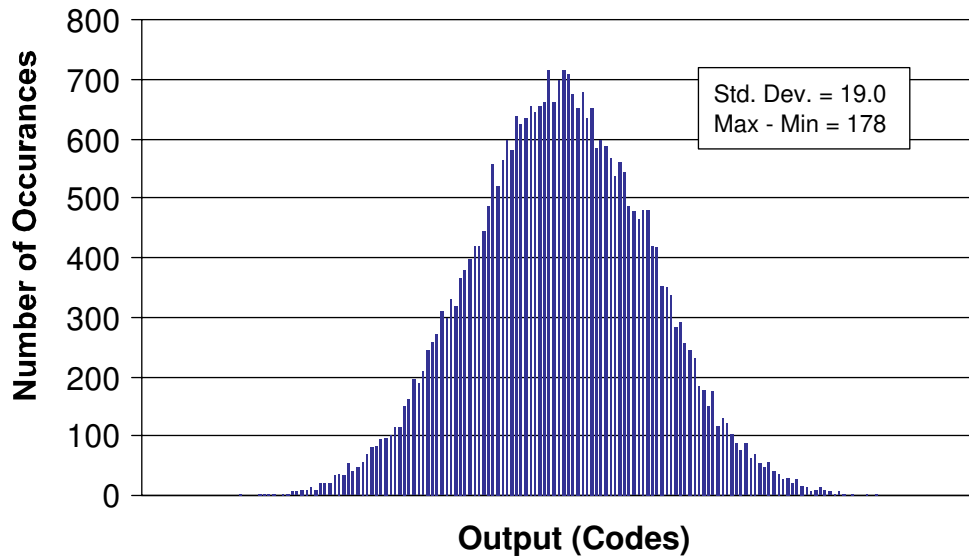

Figure 18. Noise Histogram (32k Samples)

3.9 Digital Filter Characteristics

The digital filter is designed for fast settling, therefore it exhibits very little in-band attenuation. The filter attenuation is 1.040 dB at 25 kHz when sampling at 50 kSps.

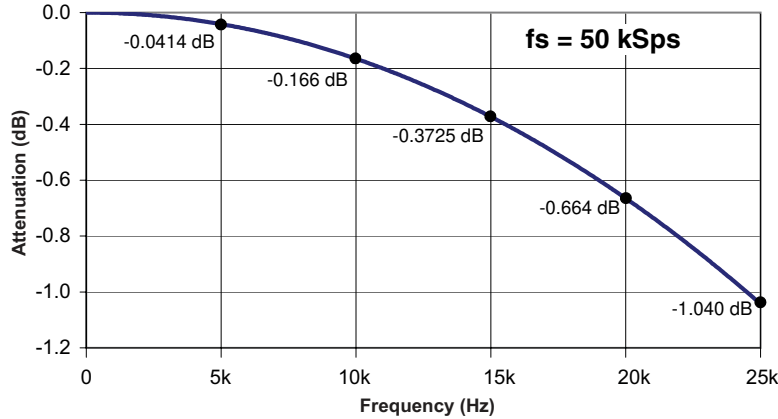

Figure 19. CS5560 Digital Filter Response (DC to $f_s/2$)

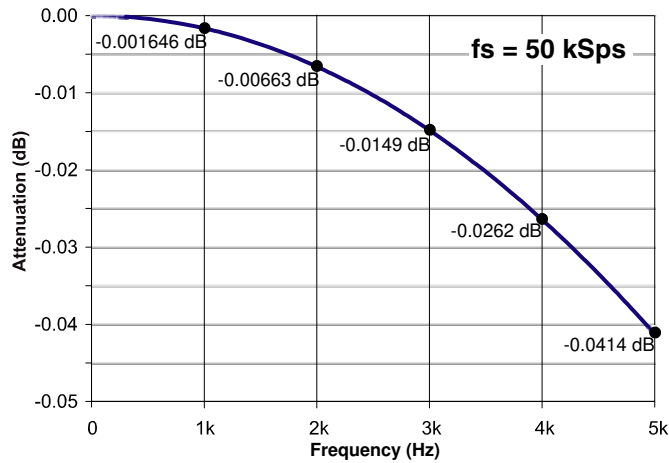

Figure 20. CS5560 Digital Filter Response (DC to 5 kHz)

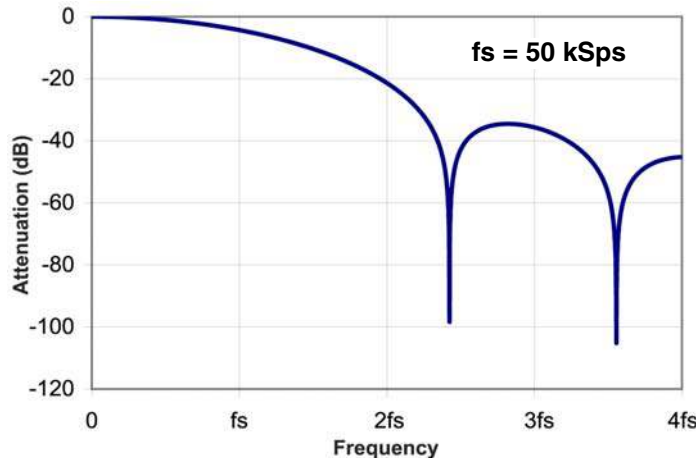

Figure 21. CS5560 Digital Filter Response (DC to $4f_s$)

3.10 Serial Port

The serial port on the CS5560 can operate in two different modes: synchronous self clock (SSC) mode & synchronous external clock (SEC) mode.

3.10.1 SSC Mode

If the SMODE pin is high (SMODE = VL), the serial port operates in the SSC (Synchronous Self Clock) mode. In the SSC mode the port shifts out conversion data words with SCLK as an output. SCLK is generated inside the converter from MCLK. Data is output from the SDO (Serial Data Output) pin. If \overline{CS} is high, the SDO and SCLK pins will stay in a high-impedance state. If \overline{CS} is low when \overline{RDY} falls, the conversion data word will be output from SDO MSB first. Data is output on the rising edge of SCLK and should be latched into the external logic on the subsequent rising edge of SCLK. When all bits of the conversion word are output from the port the \overline{RDY} signal will return to high.

3.10.2 SEC Mode

If the SMODE pin is low (SMODE = VLR), the serial port operates in the SEC (Synchronous External Clock mode). In this mode, the user usually monitors \overline{RDY} . When \overline{RDY} falls at the end of a conversion, the conversion data word is placed into the output data register in the serial port. \overline{CS} is then activated low to enable data output. Note that \overline{CS} can be held low continuously if it is not necessary to have the SDO output operate in the high impedance state. When \overline{CS} is taken low (after \overline{RDY} falls) the conversion data word is then shifted out of the SDO pin by driving the SCLK pin from system logic external to the converter.

If \overline{CS} is held low continuously, the \overline{RDY} signal will fall at the end of a conversion and the conversion data will be placed into the serial port. If the user starts a read, the user will maintain control over the serial port until the port is empty. However, if SCLK is not toggled, the converter will overwrite the conversion data at the completion of the next conversion. If \overline{CS} is held low and no read is performed, \overline{RDY} will rise just prior to the end of the next conversion and then fall to signal that new data has been written into the serial port.

3.11 Power Supplies & Grounding

The CS5560 can be configured to operate with its analog supply operating from 5V, or with its analog supplies operating from $\pm 2.5\text{V}$. The digital interface supports digital logic operating from either 1.8V, 2.5V, or 3.3V.

[Figure 6](#) on page 17 illustrates the device configured to operate from $\pm 2.5\text{V}$ analog. [Figure 7](#) on page 18 illustrates the device configured to operate from 5V analog.

To maximize converter performance, the analog ground and the logic ground for the converter should be connected at the converter. In the dual analog supply configuration, the analog ground for the $\pm 2.5\text{V}$ supplies should be connected to the VLR pin at the converter with the converter placed entirely over the analog ground plane.

In the single analog supply configuration (+5V), the ground for the +5V supply should be directly tied to the VLR pin of the converter with the converter placed entirely over the analog ground plane. Refer to [Figure 7](#) on page 18.

3.12 Using the CS5560 in Multiplexing Applications

The CS5560 is a delta-sigma A/D converter. Delta-sigma converters use oversampling as means to achieve high signal to noise. This means that once a conversion is started, the converter takes many samples to compute the resulting output word. The analog input for the signal to be converted must remain active during the entire conversion until $\overline{\text{RDY}}$ falls.

The CS5560 can be used in multiplexing applications, but the system timing for changing the multiplexer channel and for starting a new conversion will depend upon the multiplexer system architecture.

The simplest system is illustrated in [Figure 22](#). Any time the multiplexer is changed, the analog signal presented to the converter must fully settle. After the signal has settled, the $\overline{\text{CONV}}$ signal is issued to the converter to start a conversion. Being a delta-sigma converter, the signal must remain present at the input of the converter until the conversion is completed. Once the conversion is completed, $\overline{\text{RDY}}$ falls. At this time the multiplexer can be changed to the next channel and the data can be read from the serial port. The $\overline{\text{CONV}}$ signal should be delayed until after the data is read and until the new analog signal has settled. In this configuration, the throughput of the converter will be dictated by the settling time of the analog input circuit and the conversion time of the converter. The conversion data can be read from the serial port after the multiplexer is changed to the new channel while the analog input signal is settling.

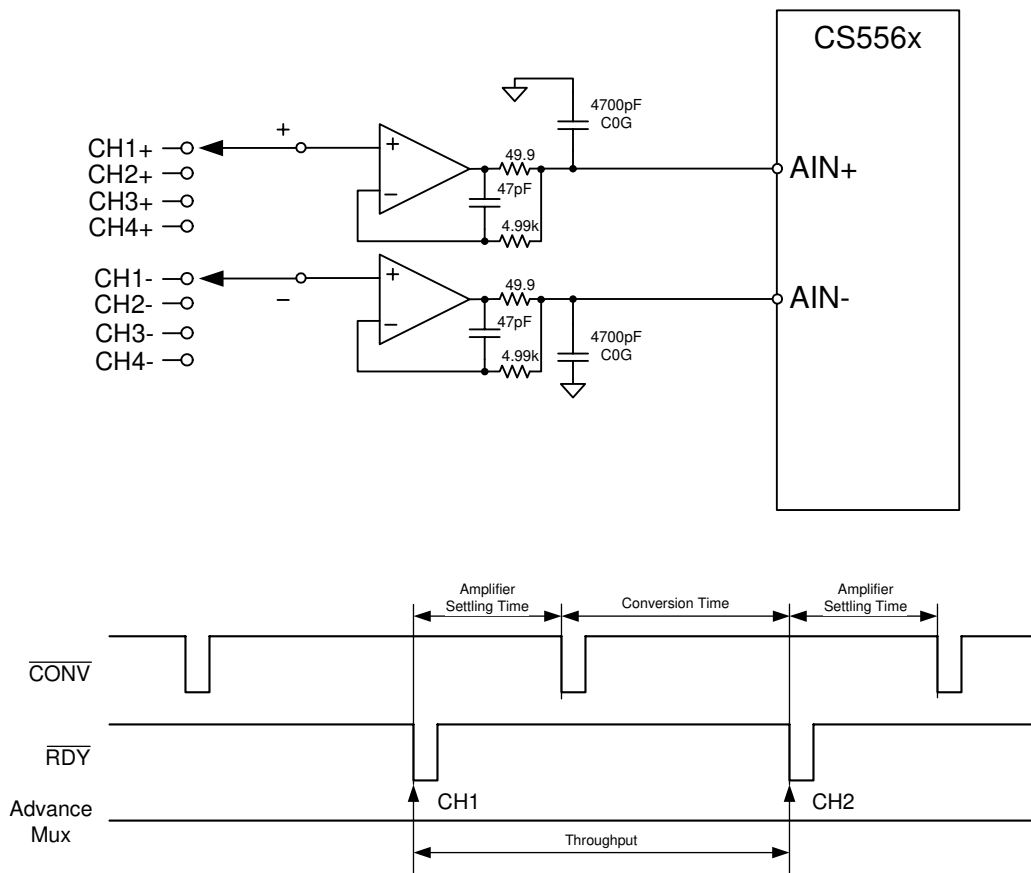

Figure 22. Simple Multiplexing Scheme

A more complex multiplexing scheme can be used to increase the throughput of the converter is illustrated in [Figure 23](#). In this circuit, two banks of multiplexers are used.

At the same time the converter is performing a conversion on a channel from one bank of multiplexers, the second multiplexer bank is used to select the channel for the next conversion. This configuration allows the buffer amplifier for the second multiplexer bank to fully settle while a conversion is being performed on the channel from the first multiplexer bank. The multiplexer on the output of the buffer amplifier and the **CONV** signal can be changed at the same time in this configuration. This multiplexing architecture allows for maximum multiplexing throughput from the A/D converter. The following figure depicts the recommended analog input amplifier circuit.

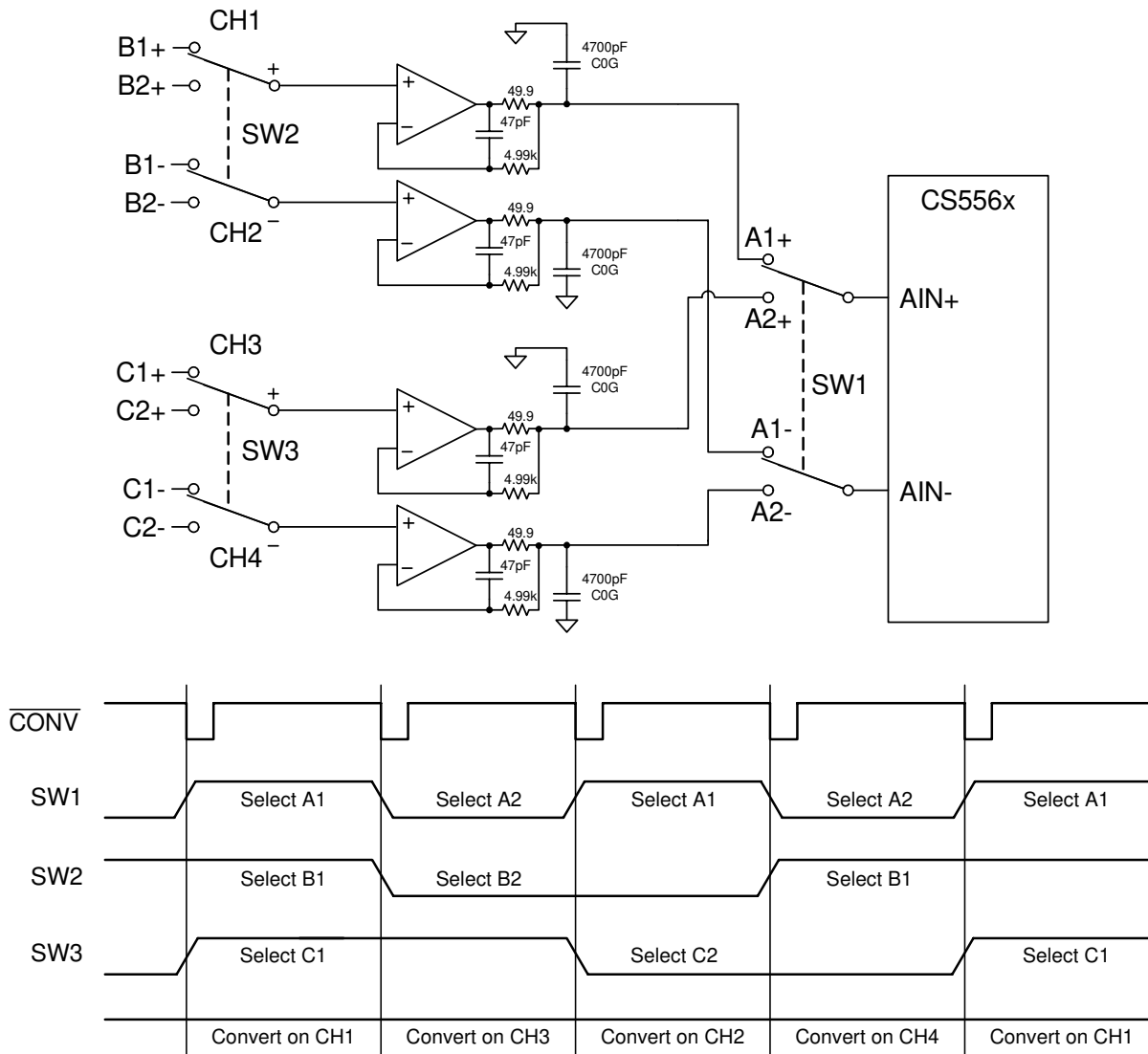
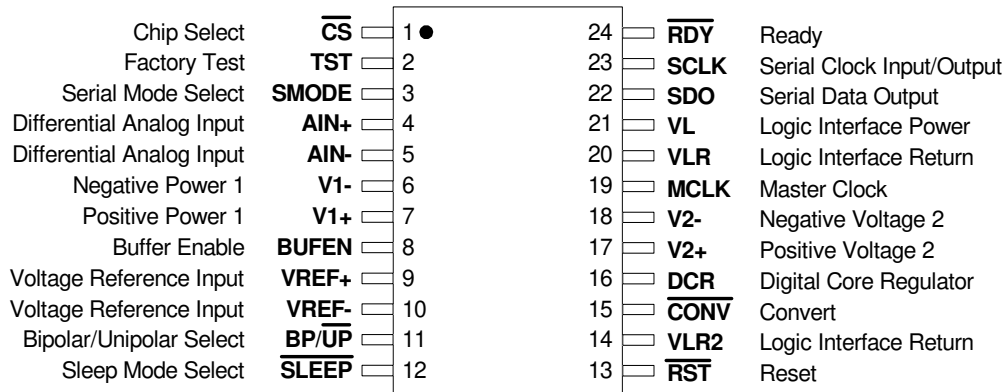

Figure 23. More Complex Multiplexing Scheme

3.13 Synchronizing Multiple Converters

Many measurement systems have multiple converters that need to operate synchronously. The converters should all be driven from the same master clock. In this configuration, the converters will convert synchronously if the same **CONV** signal is used to drive all the converters, and **CONV** falls on a falling edge of **MCLK**. If **CONV** is held low continuously, reset (**RST**) can be used to synchronize multiple converters if **RST** is released on a falling edge of **MCLK**.

4. PIN DESCRIPTIONS



$\overline{\text{CS}}$ – Chip Select, Pin 1

The Chip Select pin allows an external device to access the serial port. If SMODE = VL (SSC Mode) and $\overline{\text{CS}}$ is held high, the SDO output and the SCLK output will be held in a high-impedance output state.

TST – Factory Test, Pin 2

For factory use only. Connect to VLR.

SMODE – Serial Mode Select, Pin 3

The serial interface mode pin (SMODE) dictates whether the serial port behaves as a master or slave interface. If SMODE is tied high (to VL), the port will operate in the Synchronous Self-Clocking (SSC) mode. In SSC mode, the port acts as a master in which the converter outputs both the SDO and SCLK signals. If SMODE is tied low (to VLR), the port will operate in the Synchronous External Clocking (SEC) mode. In SEC mode, the port acts as a slave in which the external logic or microcontroller generates the SCLK used to output the conversion data word from the SDO pin.

AIN+, AIN- – Differential Analog Input, Pins 4, 5

AIN+ and AIN- are differential inputs for the converter.

V1- – Negative Power 1, Pin 6

The V1- and V2- pins provide a negative supply voltage to the core circuitry of the chip. These two pins should be decoupled as shown in the application block diagrams. V1- and V2- should be supplied from the same source voltage. For single-supply operation, these two voltages are nominally 0 V (Ground). For dual-supply operation, they are nominally -2.5 V.

V1+ – Positive Power 1, Pin 7

The V1+ and V2+ pins provide a positive supply voltage to the core circuitry of the chip. These two pins should be decoupled as shown in the application block diagrams. V1+ and V2+ should be supplied from the same source voltage. For single-supply operation, these two voltages are nominally +5 V. For dual-supply operation, they are nominally +2.5 V.

BUFEN – Buffer Enable, Pin 8

Buffers on input pins AIN+ and AIN- are enabled if BUFEN is connected to V1+ and disabled if connected to V1-.

VREF+, VREF- – Voltage Reference Input, Pins 9, 10

A differential voltage reference input on these pins functions as the voltage reference for the converter. The voltage between these pins can range between 2.4 volts and 4.2 volts, with 4.096 volts being the nominal reference voltage value.

BP/UP – Bipolar/Unipolar Select, Pin 11

The BP/UP pin determines the span and the output coding of the converter. When set high to select BP (bipolar), the input span of the converter is -4.096 volts to +4.096 volts fully differential (assuming the voltage reference is 4.096 volts) and output data is coded in two's complement format. When set low to select UP (unipolar), the input span is 0 to +4.096 fully differential and the output data is coded in binary format.

SLEEP – Sleep Mode Select, Pin 12

When taken low, the SLEEP pin will cause the converter to enter into a low-power state. SLEEP will stop the internal oscillator and power down all internal analog circuitry.

RST – Reset, Pin 13

Reset is necessary after power is initially applied to the converter. When the RST input is taken low, the logic in the converter will be reset. When RST is released to go high, certain portions of the analog circuitry are started. RDY falls when reset is complete.

CONV – Convert, Pin 15

The CONV pin initiates a conversion cycle if taken low, unless a previous conversion is in progress. When the conversion cycle is completed, the conversion word is output to the serial port register and the RDY signal goes low. If CONV is held low and remains low when RDY falls, another conversion cycle will be started.

DCR – Digital Core Regulator, Pin 16

DCR is the output of the on-chip regulator for the digital logic core. DCR should be bypassed with a capacitor to V2-. The DCR pin is not designed to power any external load.

V2+ – Positive Power 2, Pin 17

The V1+ and V2+ pins provide a positive supply voltage to the circuitry of the chip. These two pins should be decoupled as shown in the application block diagrams. V1+ and V2+ should be supplied from the same source voltage. For single-supply operation, these two voltages are nominally +5 V. For dual-supply operation, they are nominally +2.5 V.

V2- – Negative Power 2, Pin 18

The V1- and V2- pins provide a negative supply voltage to the circuitry of the chip. These two pins should be decoupled as shown in the application block diagrams. V1- and V2- should be supplied from the same source voltage. For single-supply operation, these two voltages are nominally 0 V (Ground). For dual-supply operation, they are nominally -2.5 V.

MCLK – Master Clock, Pin 19

The master clock pin (MCLK) is a multi-function pin. If tied low (MCLK = VLR), the on-chip oscillator will be enabled. If tied high (MCLK = VL), all clocks to the internal circuitry of the converter will stop. When MCLK is held high the internal oscillator will also be stopped. MCLK can also function as the input for an external CMOS-compatible clock that conforms to supply voltages on the VL and VLR pins.

VLR2, VLR, VL – Logic Interface Power/Return, Pins 14, 20, 21

VL and VLR are the supply voltages for the digital logic interface. VL and VLR can be configured with a wide range of common mode voltage. The following interface pins function from the VL/VLR supply: SMODE, CS, SCLK, SDO, RDY, SLEEP, CONV, RST, BP/UP, and MCLK.

SDO – Serial Data Output, Pin 22

SDO is the output pin for the serial output port. Data from this pin will be output at a rate determined by SCLK and in a format determined by the BP/UP pin. Data is output MSB first and advances to the next data bit on the rising edges of SCLK. SDO will be in a high impedance state when CS is high.

SCLK – Serial Clock Input/Output, Pin 23

The SMODE pin determines whether the SCLK signal is an input or an output signal. SCLK determines the rate at which data is clocked out of the SDO pin. If the converter is in SSC mode, the SCLK frequency will be determined by the master clock frequency of the converter (either MCLK or the internal oscillator). In SEC mode, the user determines the SCLK frequency.

If SMODE = VL (SSC Mode), SCLK will be in a high-impedance state when \overline{CS} is high.

 \overline{RDY} – Ready, Pin 24

At the end of any conversion \overline{RDY} falls to indicate that a conversion word has been placed into the serial port. \overline{RDY} will return high after all data bits are shifted out of the serial port or two master clock cycles before new data becomes available if the \overline{CS} pin is inactive (high); or two master clock cycles before new data becomes available if the user holds \overline{CS} low but has not started reading the data from the converter when in SEC mode.

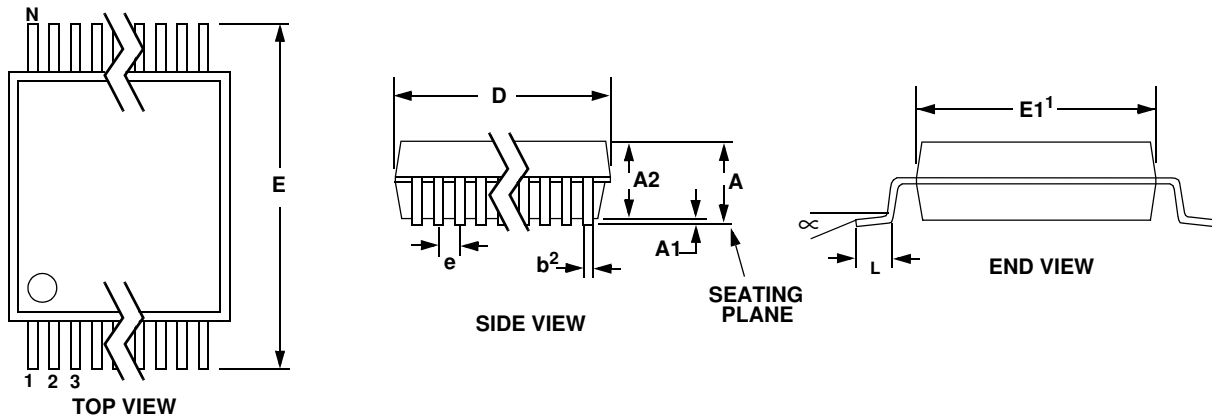
5. PACKAGE DIMENSIONS
24L SSOP PACKAGE DRAWING

DIM	INCHES			MILLIMETERS			NOTE
	MIN	NOM	MAX	MIN	NOM	MAX	
A	--	--	0.084	--	--	2.13	
A1	0.002	0.006	0.010	0.05	0.13	0.25	
A2	0.064	0.068	0.074	1.62	1.73	1.88	
b	0.009	--	0.015	0.22	--	0.38	2,3
D	0.311	0.323	0.335	7.90	8.20	8.50	1
E	0.291	0.307	0.323	7.40	7.80	8.20	
E1	0.197	0.209	0.220	5.00	5.30	5.60	1
e	0.022	0.026	0.030	0.55	0.65	0.75	
L	0.025	0.03	0.041	0.63	0.75	1.03	
∞	0°	4°	8°	0°	4°	8°	

JEDEC #: MO-150

Controlling Dimension is Millimeters.

- Notes:
1. "D" and "E1" are reference datums and do not include mold flash or protrusions, but do include mold mismatch and are measured at the parting line, mold flash or protrusions shall not exceed 0.20 mm per side.
 2. Dimension "b" does not include dambar protrusion/intrusion. Allowable dambar protrusion shall be 0.13 mm total in excess of "b" dimension at maximum material condition. Dambar intrusion shall not reduce dimension "b" by more than 0.07 mm at least material condition.
 3. These dimensions apply to the flat section of the lead between 0.10 and 0.25 mm from lead tips.

6. ORDERING INFORMATION

Model	Linearity	Temperature	Conversion Time	Throughput	Package
CS5560-ISZ	0.0005%	-40 to +85 °C	20 μs	50 kSps	24-pin SSOP

7. ENVIRONMENTAL, MANUFACTURING, & HANDLING INFORMATION

Model Number	Peak Reflow Temp	MSL Rating*	Max Floor Life
CS5560-ISZ	260 °C	3	7 Days

* MSL (Moisture Sensitivity Level) as specified by IPC/JEDEC J-STD-020.

8. REVISION HISTORY

Revision	Date	Changes
PP1	MAR 2008	Preliminary Release.

Contacting Cirrus Logic Support

For all product questions and inquiries contact a Cirrus Logic Sales Representative.

To find the one nearest to you go to www.cirrus.com

IMPORTANT NOTICE

"Preliminary" product information describes products that are in production, but for which full characterization data is not yet available.

Cirrus Logic, Inc. and its subsidiaries ("Cirrus") believe that the information contained in this document is accurate and reliable. However, the information is subject to change without notice and is provided "AS IS" without warranty of any kind (express or implied). Customers are advised to obtain the latest version of relevant information to verify, before placing orders, that information being relied on is current and complete. All products are sold subject to the terms and conditions of sale supplied at the time of order acknowledgment, including those pertaining to warranty, indemnification, and limitation of liability. No responsibility is assumed by Cirrus for the use of this information, including use of this information as the basis for manufacture or sale of any items, or for infringement of patents or other rights of third parties. This document is the property of Cirrus and by furnishing this information, Cirrus grants no license, express or implied under any patents, mask work rights, copyrights, trademarks, trade secrets or other intellectual property rights. Cirrus owns the copyrights associated with the information contained herein and gives consent for copies to be made of the information only for use within your organization with respect to Cirrus integrated circuits or other products of Cirrus. This consent does not extend to other copying such as copying for general distribution, advertising or promotional purposes, or for creating any work for resale.

CERTAIN APPLICATIONS USING SEMICONDUCTOR PRODUCTS MAY INVOLVE POTENTIAL RISKS OF DEATH, PERSONAL INJURY, OR SEVERE PROPERTY OR ENVIRONMENTAL DAMAGE ("CRITICAL APPLICATIONS"). CIRRUS PRODUCTS ARE NOT DESIGNED, AUTHORIZED OR WARRANTED FOR USE IN PRODUCTS SURGICALLY IMPLANTED INTO THE BODY, AUTOMOTIVE SAFETY OR SECURITY DEVICES, LIFE SUPPORT PRODUCTS OR OTHER CRITICAL APPLICATIONS. INCLUSION OF CIRRUS PRODUCTS IN SUCH APPLICATIONS IS UNDERSTOOD TO BE FULLY AT THE CUSTOMER'S RISK AND CIRRUS DISCLAIMS AND MAKES NO WARRANTY, EXPRESS, STATUTORY OR IMPLIED, INCLUDING THE IMPLIED WARRANTIES OF MERCHANTABILITY AND FITNESS FOR PARTICULAR PURPOSE, WITH REGARD TO ANY CIRRUS PRODUCT THAT IS USED IN SUCH A MANNER. IF THE CUSTOMER OR CUSTOMER'S CUSTOMER USES OR PERMITS THE USE OF CIRRUS PRODUCTS IN CRITICAL APPLICATIONS, CUSTOMER AGREES, BY SUCH USE, TO FULLY INDEMNIFY CIRRUS, ITS OFFICERS, DIRECTORS, EMPLOYEES, DISTRIBUTORS AND OTHER AGENTS FROM ANY AND ALL LIABILITY, INCLUDING ATTORNEYS' FEES AND COSTS, THAT MAY RESULT FROM OR ARISE IN CONNECTION WITH THESE USES.

Cirrus Logic, Cirrus, and the Cirrus Logic logo designs are trademarks of Cirrus Logic, Inc. All other brand and product names in this document may be trademarks or service marks of their respective owners.