

UNCONTROLLED DOCUMENT

PART NUMBER  
SSP-LT6003S24

REV.  
A

REV.	E.C.N. NUMBER AND REVISION COMMENTS	DATE
A	E.C.N. #10994.	5.28.03

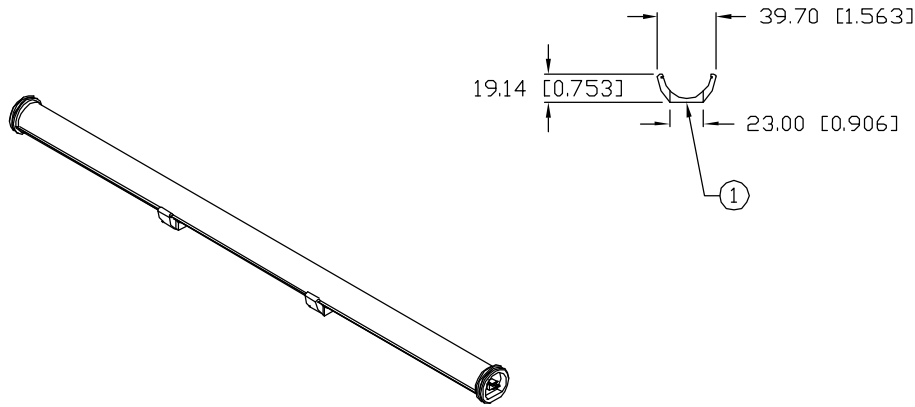

ELECTRO-OPTICAL CHARACTERISTICS  $T_A=25^{\circ}\text{C}$   $V_f=24\text{V}$

PARAMETER	MIN	TYP	MAX	UNITS	TEST COND
PEAK WAVELENGTH		590		nm	
FORWARD VOLTAGE		24		$V_f$	
REVERSE VOLTAGE	5.0			$V_r$	$I_f=100\mu\text{A}$
AXIAL INTENSITY *		100		mcd	$V_f=24\text{V}$
VIEWING ANGLE		180		2x theta	

EMITTED COLOR: YELLOW

LENS FINISH: WATER CLEAR

\* INTENSITY PER LED

LIMITS OF SAFE OPERATION AT  $25^{\circ}\text{C}$  PER DIE

PARAMETER	MAX	UNITS
PEAK FORWARD CURRENT*	150	mA
STEADY CURRENT	25	mA
POWER DISSIPATION	105	mW
DERATE FROM $25^{\circ}\text{C}$	- 1.2	mW/ $^{\circ}\text{C}$
OPERATING, STORAGE TEMP.	- 40 TO +85	$^{\circ}\text{C}$
SOLDERING TEMP.	+ 260	$^{\circ}\text{C}$
2.0mm FROM BODY		3 SEC. MAX

\*  $t < 10\mu\text{s}$

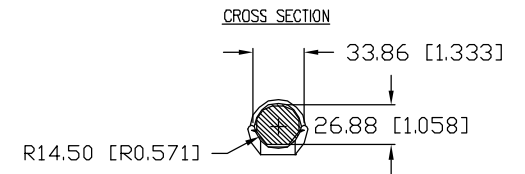
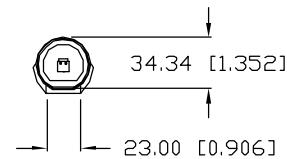
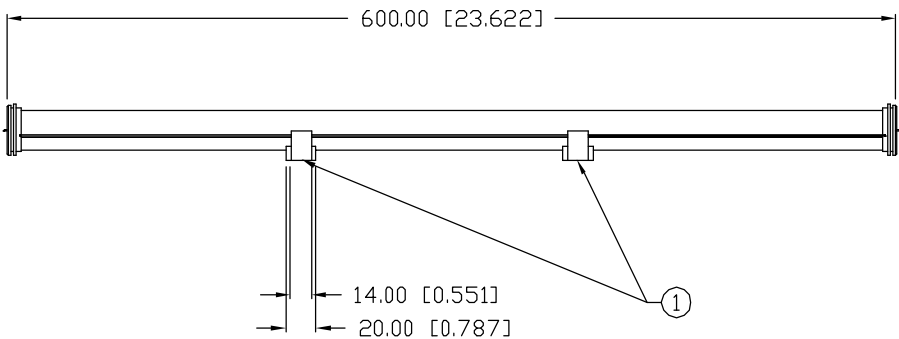

NOTES:

1. MOUNTING BRACKETS (2 PCS.)

UNCONTROLLED DOCUMENT

\*UNLESS OTHERWISE SPECIFIED TOLERANCES PER DECIMAL PRECISION ARE: X=±1 (±0.039), X.X=±0.5 (±0.020), X.XX=±0.25 (±0.010), X.XXX=±0.127 (±0.005). LEAD SIZE=±0.05 (±0.002), LEAD LENGTH=±0.75 (±0.030). MIN.= +0.00 -0.00 DECIMAL PRECISION MAX.= +0.00 -0.00 DECIMAL PRECISION

REV.	PART NUMBER
A	SSP-LT6003S24

2' YELLOW LED TUBE, 590nm AlInGaP YELLOW LEDS,  
36 LEDS PER TUBE, WATER CLEAR PLASTIC,  
WITH 2 MOUNTING BRACKETS.

**CONFIDENTIAL INFORMATION**  
THE INFORMATION CONTAINED IN THIS DOCUMENT IS THE PROPERTY OF SUNBRITE LEDS. EXCEPT AS SPECIFICALLY AUTHORIZED IN WRITING BY SUNBRITE LEDS, THE HOLDER OF THIS DOCUMENT SHALL KEEP ALL INFORMATION CONTAINED HEREIN CONFIDENTIAL AND SHALL PROTECT SAME IN WHOLE OR IN PART FROM DISCLOSURE AND DISSEMINATION TO ALL THIRD PARTIES.

**RELIABILITY NOTE**  
OUR MANY YEARS OF EXPERIENCE DATA ACCUMULATION INDICATE THAT SOLDER HEAT IS A MAJOR CAUSE OF EARLY AND FUTURE FAILURE. PLEASE PAY ATTENTION TO YOUR SOLDERING PROCESS.



286 E. HELEN ROAD  
PALATINE, IL 60067-6976  
PHONE: +1.847.359.2790  
FAX: +1.847.359.2867  
WEB: www.sunbriteleds.com

DRAWN: BC	CHECKED:	APPROVED:	DATE: 7.2.02 PAGE: 1 OF 1
--------------	----------	-----------	------------------------------