

Recommended PCB Layout
(Top View)

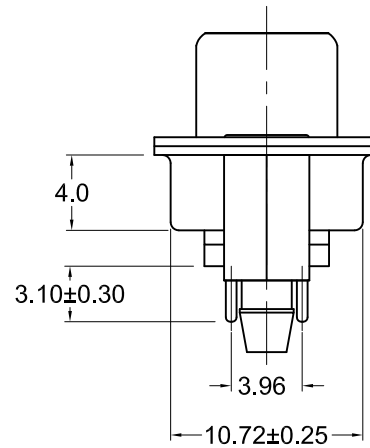
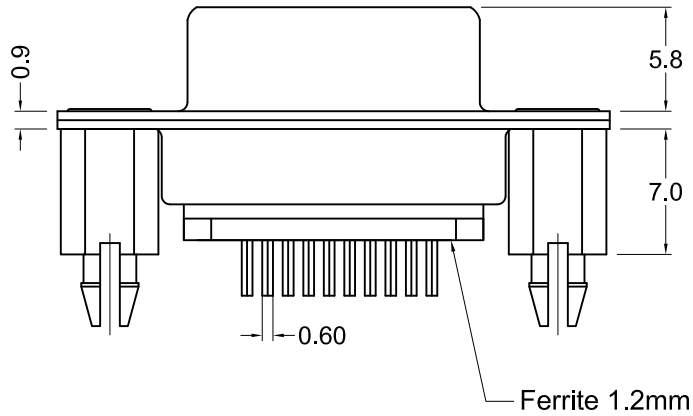

Material and Finish

- Shell: Steel, nickel plated
- Insulator: PBT thermoplastic with glass-fiber reinforcement, UL94V-0 rated, Color: Black
- Contact Material: Socket - Brass
- Contact Plating Options:
 - Standard: gold flash on mating end, tin on termination end, nickel underplate on entire contact
 - 15 Option: 15u" gold on mating end, tin on termination end, nickel underplate on entire contact
 - 30 Option: 30u" gold on mating end, tin on termination end, nickel underplate on entire contact

Electrical Specifications

- Rated Current: 1.5A
- Rated Voltage: 30Vac
- Insulation Resistance: more than 1000 megohms at 500V DC
- Contact Resistance: 13 milliohms max.
- Dielectric Withstanding Voltage: 1000V for 1 minute
- Operating Temperature: -55°C to +75°C

Ordering Information	
Part Number	Contact Area Plating Finish
KF86X-ED-15S-BR	Gold Flash (standard option)
KF86X-ED-15S-BR15	15u" Gold (15 option)
KF86X-ED-15S-BR30	30u" Gold (30 option)

Ferrite Specifications	
Measured Value(OHM)	Test Frequency
12 MIN.	25 MHz.
30 MIN.	100 MHz.



Tolerances
X.X ± 0.30
X.XX ± 0.20
Unless Stated
Otherwise

REV.	DATE	DESCRIPTION	REV. BY	CHK. BY	DRAWN BY	DATE
A1	9/5/06	New Drawing	R. Aguirre	H. MA	R. Aguirre	05/04/06
A2	1/21/08	ECO# 07-052	WILL H.	H. MA		
A3	10/20/14	ECO#14-028	H. MA	P. DalCanto	UNITS	mm
A4	05/13/16	ECO#16-009	H. MA	W. Cook		
A5	12/31/17	ECO #17-033	J. Elbanna	C. Furumasu		

KF86X-ED-15S-BR

Vertical D-sub, High Density, RoHS Compliant

15 Pin Female, Boardlocks with Ferrite

